

BER-VAC

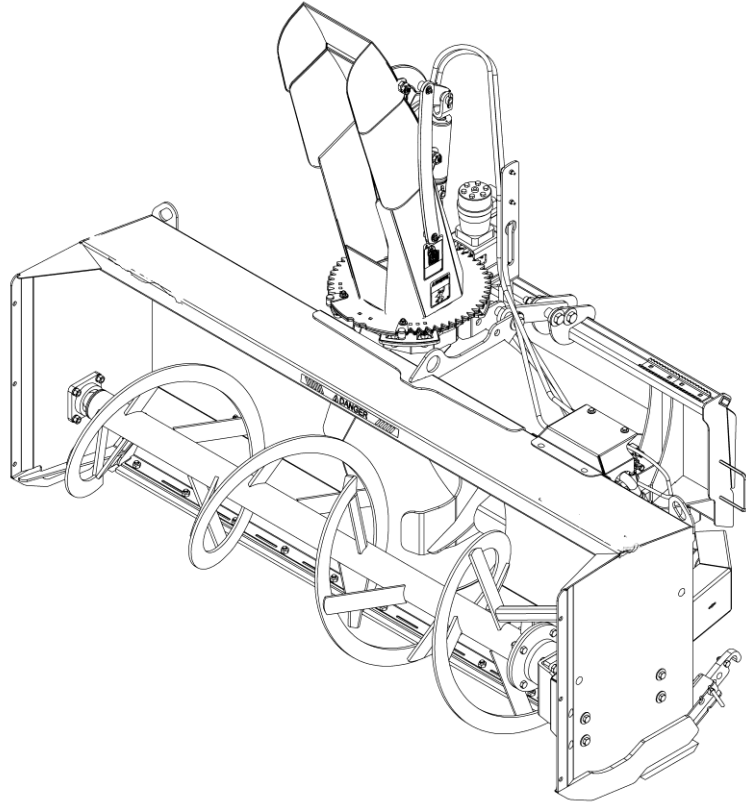

OPERATORS MANUAL

76" HYDRAULIC SNOWBLOWER – H76H
84" HYDRAULIC SNOWBLOWER – H84H

SERIAL NO. 22500001 AND UP

**CAUTION: THIS IS A HIGH FLOW SNOWBLOWER, LOW FLOW WILL RESULT IN
POOR PERFORMANCE.**

INTRODUCTION

TO THE PURCHASER

All products are designed to give safe, dependable service if they are operated and maintained according to instructions. **Read and understand this manual before operation, and keep it in your files for further reference.**

This manual has been prepared to assist the owner and operators in the safe operation and suitable maintenance of the equipment. The information is applicable to products at the time of manufacture and does not include modifications made afterwards.

Read and understand this operator's manual before attempting to put equipment into service. Familiarize yourself with the operating instructions **AND ALL THE SAFETY RECOMMENDATIONS** contained in this manual and those labeled on the equipment and on the machine. Follow the safety recommendations and make sure that those with whom you work follow them

TO THE DEALER

Give this manual to the owner upon delivery of the equipment.

TO THE PURCHASER AND THE DEALER

Illustrations

The illustrations may not necessarily reproduce the full detail and the exact shape of the parts or depict the actual models, but are for reference only.

Direction Reference

All references to right and left, forward or rearward are from the operator seat.

To assist your dealer in handling your needs, please record hereafter the model number and serial number of your equipment and machine. It is also advisable to supply them to your insurance company. It will be helpful in the event that equipment or machine is lost or stolen

MODEL: _____

SERIAL NUMBER: _____

DATE OF PURCHASE: _____



DEALER NAME: _____

DEALER TELEPHONE NUMBER: _____

All products are designed to give safe, dependable service if they are operated and maintained according to instructions. **Read and understand this manual before operation**. It is the owner's responsibility to be certain anyone operating this product reads this manual, and all other applicable manuals, to become familiar with this equipment and all safety precautions. Failure to do so could result in serious personal injury or equipment damage. If you have any questions, consult your dealer.

SAFETY FIRST

This symbol, the industry's "Safety Alert Symbol", is used throughout this manual and on labels on the machine itself to warn of the possibility of personal injury. Read these instructions carefully. It is essential that you read the instructions and safety regulations before you attempt to assemble or use this unit.

-  **DANGER :** Indicates an imminently hazardous situation which, if not avoided, will result in death or serious injury.
-  **WARNING :** Indicates a potentially hazardous situation which, if not avoided, could result in death or serious injury.
-  **CAUTION :** Indicates a potentially hazardous situation which, if not avoided, may result in minor or moderate injury.
- IMPORTANT :** Indicates that equipment or property damage could result if instructions are not followed.
- NOTE :** Gives helpful information.

Legal Disclaimer

Rad Tech notes that specifications and technical information are subject to change without notice and Rad Tech does not represent or warrant that the information in this publication is completely accurate or current; however, Rad Tech used reasonable efforts to set forth and include accurate and up to date information in this publication. Rad Tech disclaims all representations and warranties, whether express or implied, including, but not limited to, warranties of merchantability and fitness for a particular purpose and Rad Tech shall not be liable for any damages, whether compensatory, direct, indirect, incidental, special, or consequential, arising out of or in connection with the use of this publication, or the information therein.

The Product(s) described in this Publication are designed and manufactured only for the country in which they are initially wholesaled by Rad Tech. Rad Tech does not provide parts, warranty or service for any Product which is re-sold or retailed in any country other than the country for which the Product(s) were designed or manufactured.

TABLE OF CONTENTS

INTRODUCTION.....	1
TABLE OF CONTENTS	3
SAFETY INFORMATION	4
SAFETY LABELS.....	8
SPECIFICATIONS.....	10
ESTIMATED ASSEMBLY TIME	11
ASSEMBLY	12
Tractor Preparation.....	12
Snowblower Assembly.....	12
Installation of the 3 Part Chute of H76H.....	12
UNPACKING H84H.....	15
Installation of the 3 Part Chute of H84H.....	15
OPERATION	19
Optimum Performances.....	19
General Preparation	19
Operating controls	19
Hydraulic Deflector Adjustment.....	19
Hydraulic Rotation Adjustment.....	19
Ground Speed	20
Skid Shoes Adjustment.....	20
SNOW REMOVAL METHODS.....	21
MAINTENANCE	22
LUBRICATION	23
Instruction For Valve Adjustment.....	24
Instruction to Take Off the Motor Adaptor of the Auger.....	28
Instruction to Take Off the Impeller	29
STORAGE.....	30
TROUBLESHOOTING	31
Optimum Performance	31
PARTS	33
MANUAL HOLDER.....	33
THREE PART CHUTE	34
76" SNOWBLOWER ASSEMBLY - FRONT.....	36
84" SNOWBLOWER ASSEMBLY - FRONT.....	38
84" SNOWBLOWER ASSEMBLY - REAR	40
76" SNOWBLOWER ASSEMBLY - REAR.....	42
HITCH FOR 76" SNOWBLOWER.....	43
HITCH FOR 84" SNOWBLOWER.....	44
HYDRAULIC SYSTEM.....	45
HYDRAULIC MOTOR	47
HYDRAULIC BLOCK.....	49
HYDRAULIC & ELECTRIC SCHEMATICS.....	50
TORQUE SPECIFICATION TABLE	52
ADAPTER INSTALLATION PROCESS	53

SAFETY INFORMATION

Children

Tragic accidents can occur if the operator is not alert to the presence of children. Children are generally attracted to machines and the work being done. Never assume children will remain where you last saw them

1. Keep children out of the operating area and under the watchful eye of another responsible adult.
2. Be alert and turn machine off if children enter the work area.
3. Before and when backing, look behind for small children.
4. Never carry children while operating the machine. They may fall off and be seriously injured or interfere with the safe operation of the machine.
5. Never allow children to play on the machine or attachment even when the machine is turned off.
6. Never allow children to operate the machine even under adult supervision.
7. Use extra care when approaching blind corners, shrubs, trees, or other obstructions that might hide children from sight.











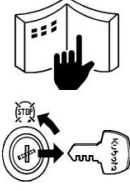



Before Operation





1. Read and understand both the vehicle AND implement operator's manual before using the snowblower. Know how to operate all controls and how to stop the unit and disengage the controls quickly. Lack of knowledge can lead to accidents.
2. Park the vehicle/implement on level ground, set the parking brake, lower the implement to the ground, place all control levers in neutral, shut off the engine and remove the ignition key and allow the rotating parts to stop BEFORE making any implement adjustments.
3. Keep clear of all rotating parts. Do not put hands or feet under, or into snowblower and subframe with engine running. Be especially observant of the snowblower areas of discharge, intake or all other mechanical motions.
4. Do not operate the vehicle/implement that is defective or has missing parts. Make sure that all recommended maintenance procedures are completed before operating the unit.

5. Keep the vehicle/implement clean. Snow, dirt or ice build-up can lead to malfunction or personal injury from thawing and refreezing in garage. Inspect and clean every rotating parts.
6. Do not modify or alter this implement or any of its components, or any implement function without first consulting your dealer. The manufacturer will not claim responsibility for fitment of unapproved parts and/or accessories and any damages as a result of their use.
7. Verify that all vehicle/implement safety protective devices are in place. Shields, guards and covers must be correctly installed at all times. When necessary to remove these for servicing, cleaning, or repair work, they must be reinstalled immediately.
8. Always make sure all implement components are properly installed and securely fastened.
9. Check that all vehicle/implement drivelines are in good working order.
10. Check for moving parts excessive wear regularly. **ALWAYS USE GENUINE PARTS WHEN REPLACEMENT PARTS ARE REQUIRED.**
11. Adjust housing height to clear gravel or crushed rocks surface.
12. Prior to operation, clear work area and mark all curbs, pipes, etc. that cannot be moved.
13. Inspect the vehicle/implement after striking any foreign object to assure that all vehicle/implement parts are safe and secure and not damaged.
14. Handle fuel with care, as it is highly flammable. Use approved fuel container.
15. Never add fuel to a running engine or a hot engine.
16. Fill fuel tank outdoors with extreme care. Never fill fuel tank indoors. Replace fuel cap securely and wipe up spilled fuel.
17. Check all vehicle controls regularly and adjust where necessary. Make sure that the brakes are evenly adjusted. Periodically check all nuts and bolts for tightness, especially wheel hub and rim nuts.
18. Make sure the vehicle is counterweighted and has tire chains for better traction and stability as recommended by your dealer. Weights provide the necessary balance to improve stability, traction and steering. Use only those recommended by your dealer.

During Operation

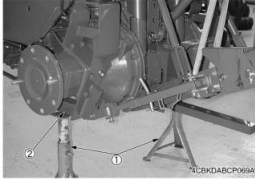
1. Never allow anyone to operate the vehicle and implement until they have read the manuals completely and are thoroughly familiar with their basic operation. Lack of operating knowledge can lead to accidents.
2. Do not allow anyone to ride on the vehicle/implement at any time. The only one allowed is the operator that MUST sit in the driver seat.
3. Never allow anyone near the work area. The debris that can be thrown could cause serious personal injuries.
4. Never stand alongside of the snowblower while the engine is running.
5. Never operate the implement without safety protective devices in place. All vehicle/implement shields, guards and covers must always be correctly installed.
6. Keep clear of all rotating parts. Do not put hands or feet under, or into snowblower with engine running. Be especially observant of the snowblower areas of discharge, intake or all other mechanical motions.
7. Park the vehicle/snowblower on level ground, place the transmission in neutral, set the parking brake, disengage the Machine Auxiliary Hydraulics, lower the snowblower to the ground, place all control levers in neutral, shut off the engine, remove the ignition key and allow the rotating parts to stop BEFORE unclogging the housing or the chute and making any repairs, adjustments or inspections. Use only a 36" long stick of wood to unclog the snowblower.
8. If the snowblower starts to vibrate abnormally, disengage the auxiliary hydraulics, stop the engine immediately and check for cause. Excessive vibration is generally a sign of trouble.
9. Park the vehicle/implement on level ground, place the transmission in neutral, set the parking brake, disengage the driving system, lower the equipment to the ground, place all levers including auxiliary control levers in neutral, shut off the engine and remove the ignition key BEFORE LEAVING THE VEHICLE.
10. Always drive the vehicle at speeds compatible with safety, especially when operating over rough ground, crossing ditches, slippery surface or when turning.
11. Operate only with a good visibility and during daylight hours, or when the area is well lit with bright artificial light.
12. Never operate snowblower near glass enclosures, automobiles, window wells, embankments, etc., without proper adjustment of snow discharge angle.
13. Keep away from chute discharge. This chute has the capacity to throw debris at far distances.
14. Never direct chute discharge towards people or animals. A thrown debris can cause serious injury.
15. Exercise extreme caution when operating on or crossing a gravel drive, walks, or roads. Stay alert for hidden hazards or traffic.
16. Use extra caution when backing up.
17. Operate up and down (not across) intermediate slopes. Avoid sudden starts and stops.
18. Drive machine backwards up steeper slopes with snowblower off. Then operate as you travel down the slope.
19. Never park the vehicle on a steep slope. Do not attempt to operate on steep slopes. If operating on slopes is necessary, exercise extreme caution when changing direction.
20. Disengage power to snowblower when transporting or when not in use.

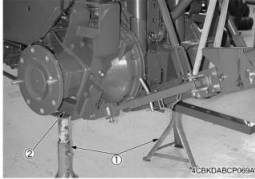
	<p>BEFORE YOU START SERVICE</p> <ul style="list-style-type: none"> • Read all instructions and safety instructions in this manual and on your machine safety decals. • Clean the work area and machine. • Park the machine on a stable and level ground, and set the parking brake. • Lower the implement to the ground. • Stop the engine, then remove the key. • Disconnect the battery negative cable. • Hang a "DO NOT OPERATE" tag in the operator station. 		<p>No Smoking or Open Flames while Fueling</p> <ul style="list-style-type: none"> • Fuel is extremely flammable and dangerous. Never smoke near fuel. If fuel is spilled on the machine, its engine, or electrical parts, it may cause a fire. If fuel is spilled, wipe it all up immediately. • Never smoke while filling the machine with fuel. And always tighten the fuel cap securely and wipe up any spilled fuel.
	<ul style="list-style-type: none"> • When performing maintenance on the equipment, hang the DO NOT OPERATE sign where it will be obvious from and around the driver's seat. • When performing maintenance or repairs, always lower attachments to the ground, stop the engine and secure the tracks with blocks. • When performing maintenance on the equipment, always disconnect the negative battery cable. • Before using tools, make sure you understand how to use them correctly and use tools in good condition and of the right size for the job. 		<ul style="list-style-type: none"> • Before getting on/off of the machine, clean off around the steps so there is no mud on them. Always give yourself 3-point support when getting on/off the machine. <p>CAUTION</p> <ul style="list-style-type: none"> • 3-point support means using both legs and one hand or both hands and one leg as you climb up/down.
	<p>START SAFELY</p> <ul style="list-style-type: none"> • Do not do the procedures below when you start the engine. <ul style="list-style-type: none"> - short across starter terminals - bypass the safety start switch • Do not alter or remove any part of machine safety system. • Before you start the engine, make sure that all shift levers are in neutral positions or in disengaged positions. • Do not start the engine when you stay on the ground. Start the engine only from operator's seat. 		<ul style="list-style-type: none"> • Do not remove the radiator cap when the engine operates, or immediately after it stops. If not, hot water can spout out from the radiator. Only remove the radiator cap when it is at a sufficiently low temperature to touch with bare hands. Slowly loosen the cap to release the pressure before you remove it fully.
	<p>Starting the Machine Safely</p> <ul style="list-style-type: none"> • Before starting the engine, always sit in the driver's seat and make sure the area is safe and clear. • As it is dangerous, never start the engine from anywhere but the driver's seat. • Always check and make sure control lever(s) are not engaged before starting the engine. • Never start the engine by hot-wiring the starter circuit. This is not only dangerous, but may damage the machine. 		<ul style="list-style-type: none"> • The engine, muffler, radiator, hydraulic line, etc., have parts that remain very hot even after the engine has been stopped. Be sure to avoid these parts, as touching them can result in burns. Radiator coolant, hydraulic fluid and oil also remain hot. Therefore, do not attempt to remove caps and plugs, etc., before these fluids have sufficiently cooled. • Make sure the coolant temperature has dropped sufficiently before opening the radiator cap. Also, since the inside of the radiator is pressurized, when removing the cap, first loosen it to release the pressure before removing the cap completely.
	<ul style="list-style-type: none"> • Wear clothes appropriate for working on equipment. Do not wear loose-fitting clothes as they may catch on the machine controls. • When working on the equipment, use all safety gear, such as a helmet, safety glasses and shoes, that are required by law or regulation. • Never perform maintenance while drowsy or under the influence of alcohol or drugs. 		<ul style="list-style-type: none"> • Grease is under high pressure inside the hydraulic cylinder. It is very dangerous to loosen a grease nipple quickly as it may shoot off. Always loosen grease nipples slowly. • And never face a grease nipple while loosening it.
	<p>Be Ready for an Emergency</p> <ul style="list-style-type: none"> • Keep a first-aid kit and fire extinguisher close at hand so you can use it when needed. • Keep emergency contact information for doctors, hospitals and ERs handy. 		<p>PREVENT A FIRE</p> <ul style="list-style-type: none"> • Fuel is very flammable and explosive under some conditions. Do not smoke or let flames or sparks in your work area. • To prevent sparks from an accidental short circuit, always disconnect the battery negative cable first and connect it last. • The battery gas can cause an explosion. Keep the sparks and open flame away from the top of battery, especially when you charge the battery. • Make sure that you do not spill fuel on the engine.
	<p>KEEP A GOOD AIRFLOW IN THE WORK AREA</p> <ul style="list-style-type: none"> • If the engine is in operation, make sure that the area has good airflow. Do not operate the engine in a closed area. The exhaust gas contains poisonous carbon monoxide. 		<p>Dispose of Waste Fluids Properly</p> <ul style="list-style-type: none"> • Never dispose of waste fluids on the ground, in the gutter, a river, pond or lake. Always dispose of hazardous substances like waste oil, coolant and electrolytic fluid in accordance with the relevant environmental protection regulations. • Keep the safety plates clean so they can be read. If a safety plate is damaged and comes off or becomes illegible, put a plate with the same warnings back in its place.

	<ul style="list-style-type: none"> The pressure in the hydraulic circuit stays at pressure even after the engine stops. Before removing parts, such as hydraulic devices from the machine, first release the pressure. Please note that when releasing residual pressure, the machine itself and/or implements may move without warning, so be very careful when releasing the pressure. Oil gushing out under pressure is extremely dangerous as it may pierce your skin or your eyes. Similarly, oil leaking out of pinholes is not visible. So when checking for oil leaks, always wear safety glasses and gloves and use a piece of cardboard or a wood block to shield yourself from oil. 		<ul style="list-style-type: none"> When you need to access the underside of the machine for maintenance purposes, but sure to support the machine with a safety stand. Getting under the machine while supporting the machine by machine's own hydraulic cylinder or using a hydraulic jack can be extremely dangerous in the event of a hydraulic fluid leakage or similar mishap. <p>(1) Safety stand (2) Secure point for safety stand</p>
	<ul style="list-style-type: none"> Do not open a fuel system under high pressure. The fluid under high pressure that stays in fuel lines can cause serious injury. Do not disconnect or repair the fuel lines, sensors, or any other components between the fuel pump and injectors on engines with a common rail fuel system under high pressure. Put on an applicable ear protective device (earmuffs or earplugs) to prevent injury against loud noises. Be careful about electric shock. The engine generates a high voltage of more than DC100 V in the ECU and is applied to the injector. 		<ul style="list-style-type: none"> Whenever it is necessary to open the engine covers or hood in order to service the machine, always prop them open. If it is absolutely necessary to run the engine while working on the machine, make sure you are clear of all rotating or moving parts. Also take care not to leave anything, such as tools or rags, near any moving parts.
	<ul style="list-style-type: none"> Engage the loader control valve lock to prevent accidental actuation when the implement is not in use or during transport. Do not utilize the valve lock for machine maintenance or repair. Do not perform machine maintenance with loader in the air. If possible, follow loader instructions to remove loader before performing maintenance. If the machine has a backhoe, engage swing and boom locks. 		

SAFETY LABELS

IMPORTANT: Keep all decals clean and legible. Replace all missing, illegible, or damaged decals.

IMPORTANT: Decal placement locations shown are approximate; decals should not be placed in a location where the operator's field of view is impeded and should not cover any portion of other decals installed in the same vicinity.

INSTALLING OR REPLACING DECALS: Thoroughly clean the area where decal is to be placed using mild soap and water. Allow the surface to fully dry. Remove the backing from the decal, exposing the adhesive surface. Apply the decal to the recommended position shown in the diagram below and smooth out any bubbles.

H76H

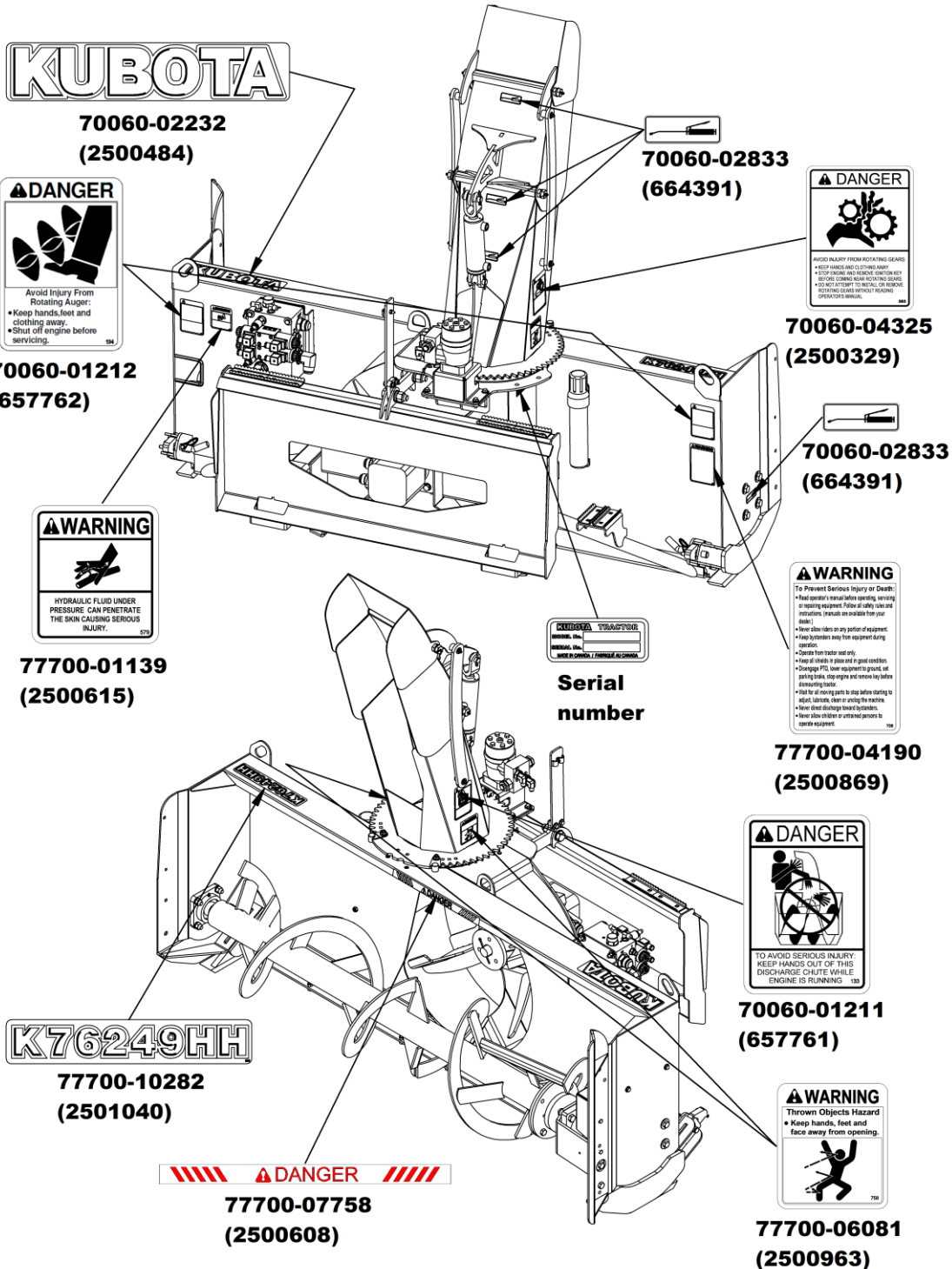

SPECIFICATIONS

	Specifications	H76H	H84H
General	Type	2 stage	2 stage
	Direction of impeller rotation	CCW	CCW
	Hydraulic flow requirements	27 – 40 gpm	27 – 40 gpm
	Max operating pressure	3600 psi	3600 psi
	Shipping weight	1660 lbs	2144Lbs
	Operating weight, incl. chute & hyd. deflector	1160 lbs	1644 lbs
	Set-up time	90 min	90 min
	Working width	75 7/8"	84 1/2"
	Working height	27 1/2"	31 3/4"
	Overall width	75 7/8"	84 1/2"
	Overall height (without chute)	27 1/2"	32 7/8"
	Overall height (with chute closed)	58 7/8"	64 1/4"
	Overall length	35 1/8"	46 7/8"
Impeller	Impeller diameter	24"	26"
	Impeller width	9"	11"
	Number of impeller blade	4	4
	Impeller drive	200cc hydraulic motor	200cc hydraulic motor
	Impeller RPM	510 - 760 RPM	510 - 760 RPM
Auger	Auger - Single / dual	Single	Single
	Main auger diameter	14 3/4"	20"
	Auger drive system	500cc hydraulic motor	500cc hydraulic motor
	Auger RPM	200 - 300 RPM	200 - 300 RPM
Housing	Housing thickness	11 Ga.	11 Ga.
	Side panel thickness	3/16"	3/16"
	Impeller housing thickness	3/16" high steel strength	3/16" high steel strength
Chute	Chute position	Right	Right
	Rotation of the chute	Hydraulic by motor	Hydraulic by motor
	Flow restrictor (rotation)	Yes	Yes
	Flow restrictor (deflector)	Yes	Yes
	Hoses support	Yes	Yes
	Deflector adjustment (2 part chute)	N/A	N/A
Deflector adjustment (3 part chute)	Hydraulic	Hydraulic	
Cutting edge	Replaceable and reversible	Yes	Yes
	Cutting edge material	Carbon Steel	Carbon Steel
	Cutting edge dimension	1/2" x 3"	1/2" x 3"
Skid shoes	Replaceable and adjustable	Yes Adjustable 7 positions	Yes Adjustable 7 positions
	Skid shoe material	Carbon steel	Carbon steel

ESTIMATED ASSEMBLY TIME

Refer to the following table for the estimated assembly time to open the package and assemble the equipment and options.

	Time
Estimated installation time, snowblower only	90 min
2nd installation time (on the tractor)	10 min

The assembly times of the table are only a reference under normal conditions according to the following assumptions:

1. The assembly is done by a competent person who is familiar with the equipment.
2. The following tools and materials are prepared:
 - Wrench set (flat wrenches)
 - Ratchet & socket set
 - Cutting pliers
 - Safety gloves and glasses

ASSEMBLY

Tractor Preparation

See Dealer for Tractor Preparation information.

Snowblower Assembly

Before assembly, separate all hardware according to size. When the assembly is complete, torque all the bolts according to the ***Torque Specification Table*** at the end of the manual.

Installation of the 3 Part Chute of H76H

1. **Figure 1:** Cut the nylon tie wrap (item 1) and remove the two anti-friction plates (item 2). Remove the hoses (item 3) from the output of the snowblower drum.

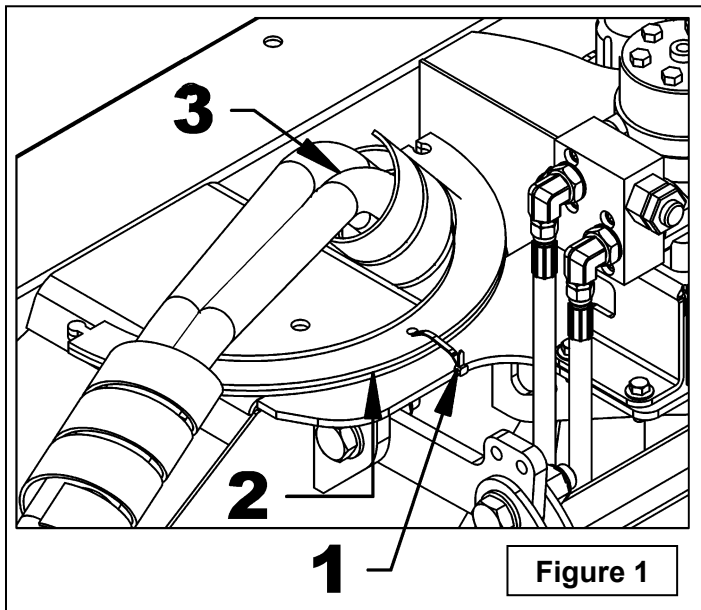

WARNING:

To avoid serious personal injury or death: **Read and understand the SAFETY INFORMATION on the previous pages before installation and operation** Perform all the assembly properly locked and supported.



WARNING:

To avoid serious personal injury or death: Park the vehicle on level ground, place the transmission in neutral, set the parking brake, disengage the drive system, put all levers to neutral, shut off the engine, remove the ignition key and wait for all movement to stop **BEFORE** starting installation.

2. **Figure 2:** Assemble together the two anti-friction plates (item 2) and place on the snowblower frame so that they are centered with the drum output.
3. **Figure 2:** Place the chute (item 1) on the anti-friction plate assembly (item 2).
4. **Figure 2:** Place a chute guide (item 3) on the chute base (item 1) and install a retaining plate (item 4) using two 1/2"NC x 1 1/2" bolts, 1/2" lockwashers, 1/2" flat washers and 1/2"NC nylon insert lock nuts (items 5-6-7-8).
5. Repeat step 4 for the two other guides and retaining plates.
6. **Figure 3:** Make sure the chute is always well centered with the output of the snowblower while assembling the other retaining plates. The anti-friction plates (item 2) should not be under the retaining plates.
7. **Figure 4:** Install the hose support on snowblower with two 3/8"NC x 1 1/4" serrated flange bolts and 3/8"NC serrated flange nuts as shown in the figure.
8. **Figure 4a:** Install a 90° elbow on each cylinder ports at an angle shown in the figure.

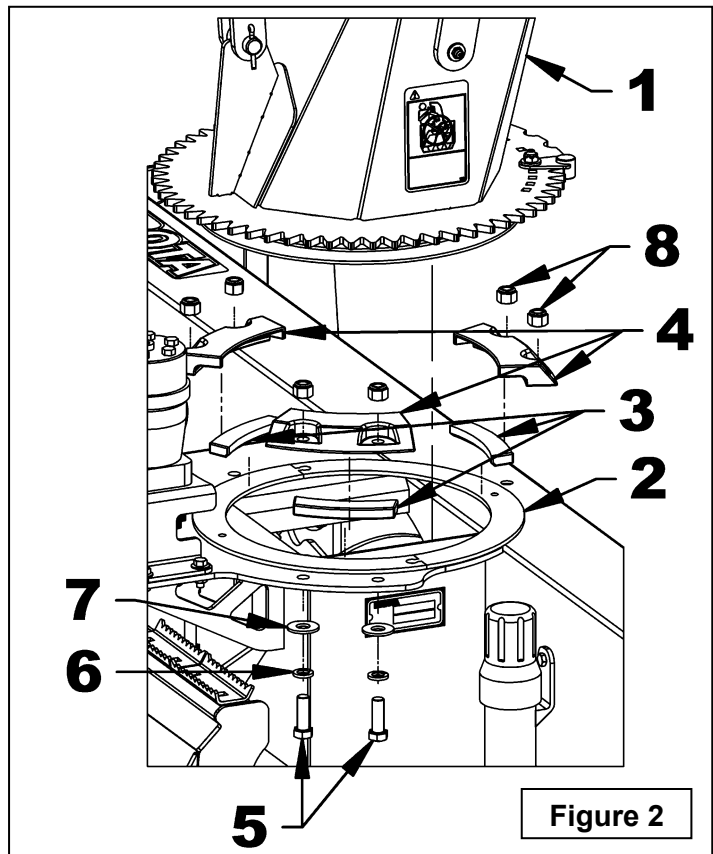

Figure 2

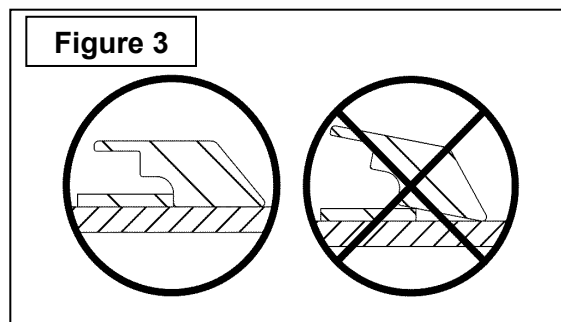

Figure 3

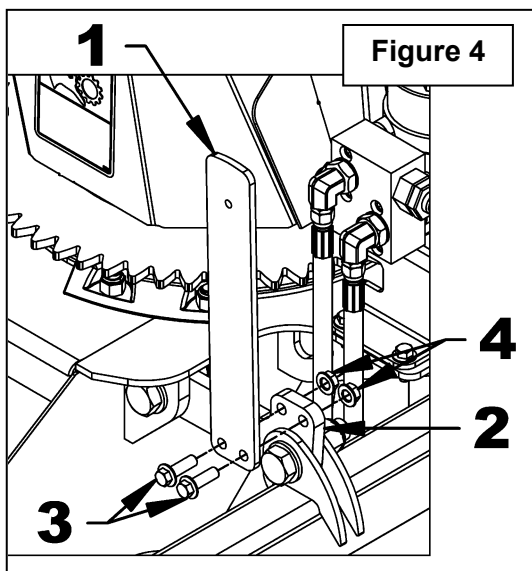

Figure 4

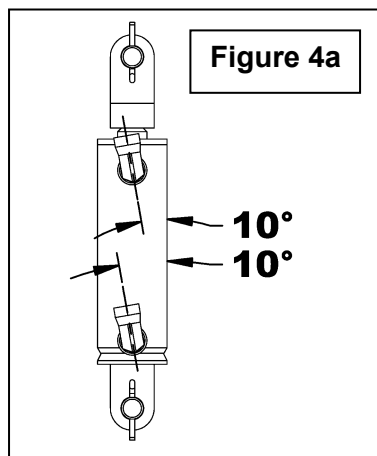
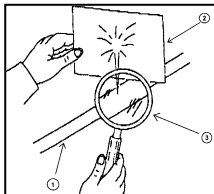

Figure 4a

9. **Figure 5:** Connect the hydraulic hose connected to the hydraulic block "C4" port (item 1) to the 90° elbow (item 2) on the cylinder rod end.
10. **Figure 5:** Connect the hydraulic hose connected to the hydraulic block "C3" port (item 3) to the 90° (item 4) on the cylinder base.
11. **Figure 5:** Attach the two hoses (items 1-3) to the hose support (item 5) with the hose clamp (item 6), the allen socket head capscrew 1/4" x 1" NC (item 7) and a 1/4" nylon insert locknut (item 8). Leave 34" of the hose (item 1) exceed from the hose clamp (item 6) and follow the same route with the other hose (item 3). Tighten the allen socket head capscrew 1/4" x 1" NC (item 7) and a 1/4" nylon insert locknut (item 8) making sure not to crush the hoses. Start installing the hose protector (item 9) 10" after the hose clamp.
12. **Figure 5:** Attach the two hoses (items 1-3) to the hoses of the fan hydraulic motor with a nylon tie wrap.

! WARNING: To avoid serious personal injury. Escaping hydraulic/diesel fluid under pressure can penetrate the skin causing serious injury.

- Do not use your hands to check for leaks. Use a piece of cardboard or paper to search for leaks.



- (1) Hydraulic hose
- (2) Cardboard
- (3) Magnifying glass

- Stop engine and relieve pressure before connecting or disconnecting lines.
- Tighten all connections before starting engine or pressurizing lines.

If any fluid is injected into the skin, obtain medical attention immediately.

IMPORTANT:

ALWAYS CONNECT THE SNOWBLOWER TO THE SKID STEER « HIGH FLOW » SYSTEM.

Pass through the guide located on the side of the skid steer hitch the three hoses with quick couplers and the 14 pin electric connector. Then connect them to the skid steer «high flow» system.

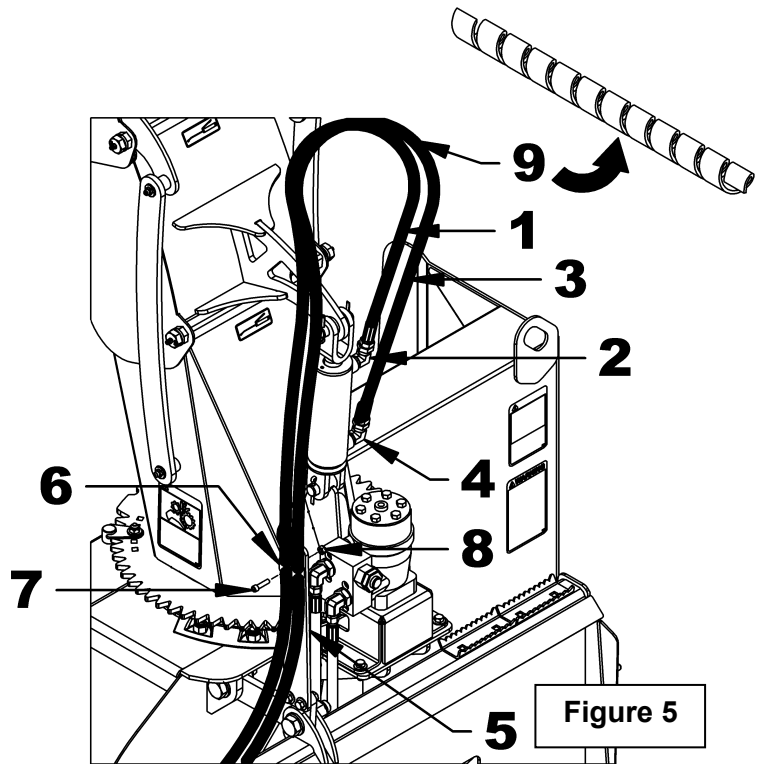
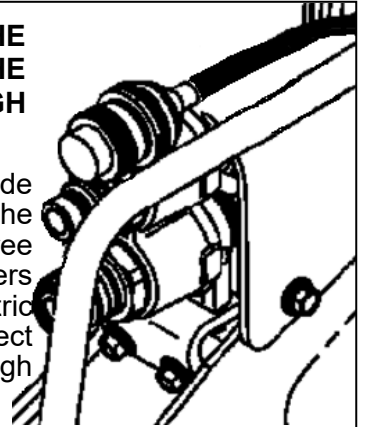

Figure 5

UNPACKING H84H

After unpacking the snowblower, replace the two cutting edge bolts used to attach the snowblower to the pallet by two 1/2"NC x 1 1/2" plow bolts and two 1/2"NC stover locknuts, included in the hardware bucket.

Installation of the 3 Part Chute of H84H (Figures 6-14)

1. **Figure 6:** Make sure the parking stand (item 1) is lowered. To do this, remove the square wire lock pin (item 2) from the parking stand (item 1), lower the parking stand and insert the square wire lock pin (item 2) in the snowblower attachment tube.
2. **Figure 6:** Cut the nylon tie wrap (item 3) and remove the two antifriction plates (item 4). Remove the hoses (item 5) from the output of the snowblower drum.

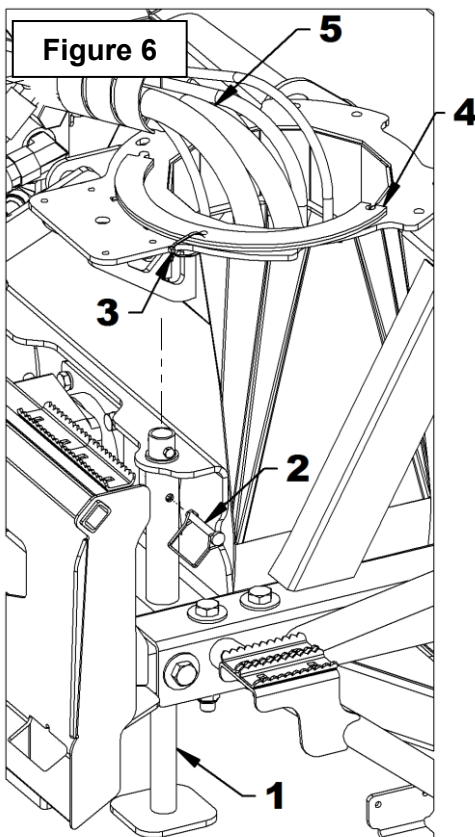

WARNING:

To avoid serious personal injury or death: Read and understand the SAFETY INFORMATION on the previous pages before installation and operation. Perform all the assembly properly locked and supported.



WARNING:

To avoid serious personal injury or death: Park the vehicle on level ground, place the transmission in neutral, set the parking brake, disengage the drive system, put all levers to neutral, shut off the engine, remove the ignition key and wait for all movement to stop **BEFORE** starting installation.

- Figure 7:** Attach the gear shield of the rotation motor assembly (item 1) and the hose support (item 2) using four 5/16" x 1 1/2" hex bolts, eight 5/16" flat washers, four 5/16" lockwashers and four 5/16" nylon insert locknuts (items 3, 4, 5, 6).

NOTE: Make sure the motor gear is secured by checking that the bolt that secures the gear to the motor is tightened.

- Figure 8:** Assemble together the two antifriction plates (item 1) and place them on the snowblower frame so that they are centered with the drum output. There are two cap screws (item 2) which serve as a guide for positioning the anti-friction plates (item 1).

- Figure 8:** Install the two retaining plates on motor sides (item 3) with two 1/2"NC x 1 1/2" hex bolts, 1/2" lockwashers and 1/2"NC nylon insert locknuts (items 4, 5, 6). Insert the chute guides (item 7) in the retaining plates (item 3).

NOTE: Make sure that the chamfer of the guides (item 7) is downwards.

- Figure 9:** Place the chute (item 1) on the antifriction plates assembly (item 2) and push the chute toward the rotation motor (item 3). If needed rotate the chute to properly engage the two gears together.

- Figure 10:** Place the other two chute guides (item 1) on the chute base. Install the two retaining plates (item 2) using two 1/2"NC x 1 1/2" hex bolts, 1/2" lockwashers, and 1/2"NC nylon insert locknuts (items 3, 4, 5).

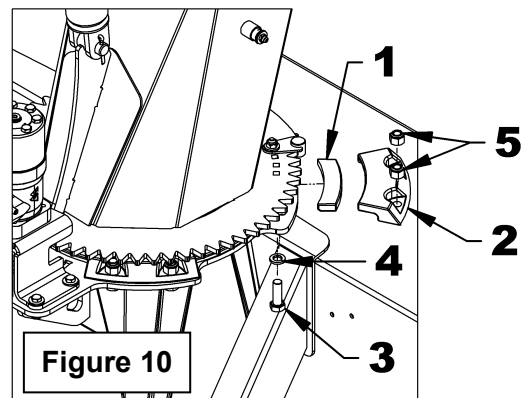
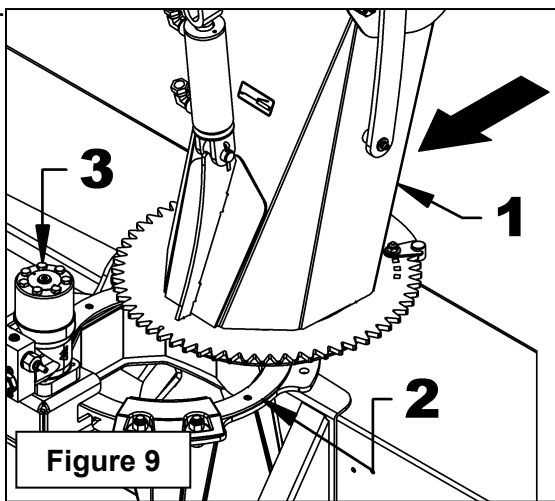
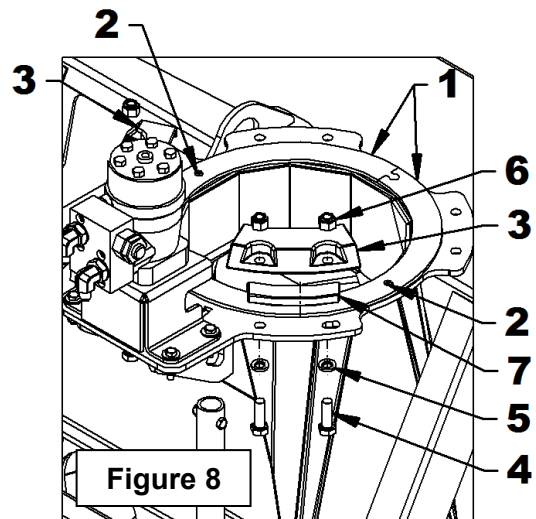
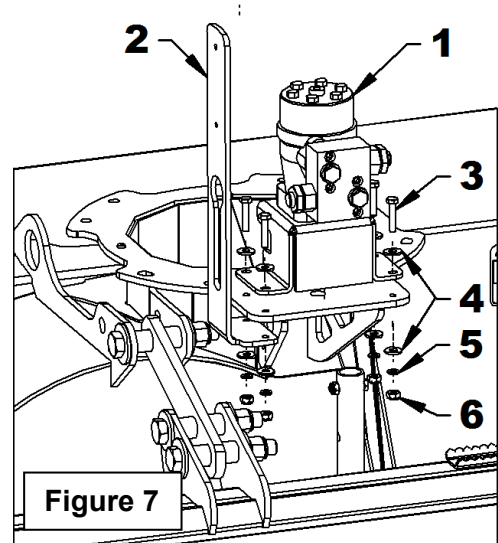

8. **Figure 10A:** Make sure that the chute is always centered with the snowblower drum output during assembly of the other retainer plates. The antifriction plates (item 1, **fig.8**) must not be below the retaining plates (item 3, **fig.8**).
9. **Figure 11:** Install a 90° elbow 7/8" ORB M x 9/16" JIC M on each motor ports at an angle shown in the figure.
10. **Figure 12:** Pass the hydraulic hose connected to the hydraulic block "C1" port (item 1) under the upper hitch (item 2) and connect it to the 90° elbow (item 3) on the hydraulic motor.
11. **Figure 12:** Pass the hydraulic hose connected to the hydraulic block "C2" port (item 4) under the upper hitch (item 2) and connect it to the 90° elbow (item 5) on the hydraulic motor.
12. **Figure 13:** Install a 90° elbow 3/8" NPT M x 3/8" NPT F on each cylinder ports at an angle shown in the figure.

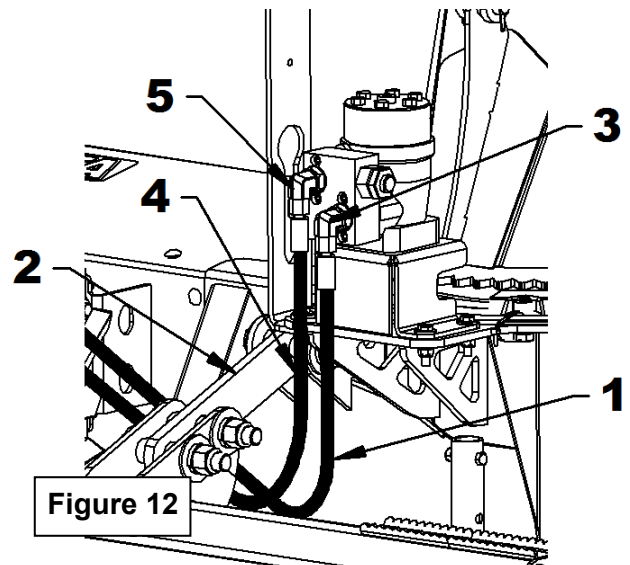
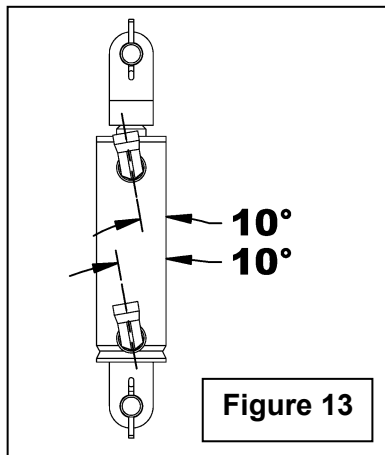
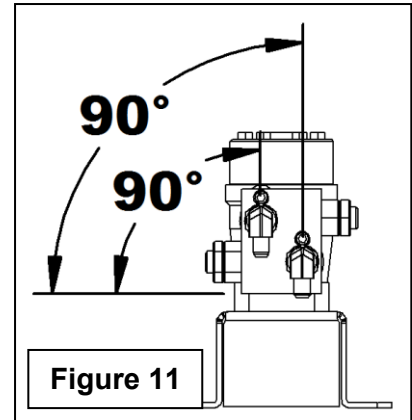
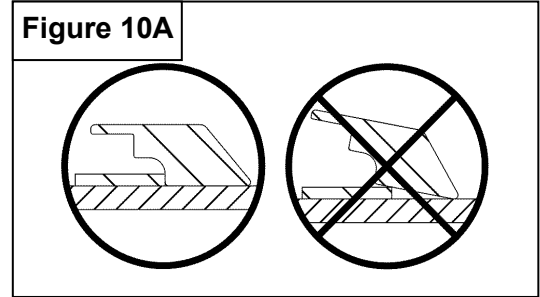

13. **Figure 14:** Pass the hydraulic hose connected to the hydraulic block "C4" port (item 1) in the hole of the hose support (item 2) and connect it to the 90° elbow (item 3) on the cylinder rod end.

14. **Figure 14:** Pass the hydraulic hose connected to the hydraulic block "C3" port (item 4) in the hole of the hose support (item 2) and connect it to the 90° (item 5) on the cylinder base.

15. **Figure 14:** Attach the two hoses (items 1, 4) to the hose support (item 2) with two hose clamps (item 6), the two 1/4" x 1" NC allen socket head capscrews (item 7) and two 1/4" nylon insert locknuts (item 8). Leave 34" of the hoses (item 1 and 4) exceed from the hose clamps (item 6). Tighten the two 1/4" x 1" NC allen socket head capscrews (item 7) and two 1/4" nylon insert locknuts (item 8) making sure not to crush the hoses. Start installing the hose protector 15" (item 9) after the hose clamp.

16. **Figure 14:** Attach the two hoses connected to the hydraulic motor (items 10 & 11) and the two hoses connected to the hydraulic cylinder (items 1 & 4) to the hoses of the hydraulic fan motor with a nylon tie wrap.



WARNING: To avoid serious personal injury. Escaping hydraulic/diesel fluid under pressure can penetrate the skin causing serious injury.

- Do not use your hands to check for leaks. Use a piece of cardboard or paper to search for leaks.

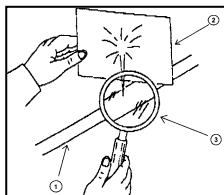
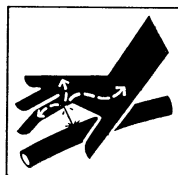

- (4) Hydraulic hose
- (5) Cardboard
- (6) Magnifying glass

- Stop engine and relieve pressure before connecting or disconnecting lines.
- Tighten all connections before starting engine or pressurizing lines.

If any fluid is injected into the skin, obtain medical attention immediately.

IMPORTANT:

ALWAYS CONNECT THE SNOWBLOWER TO THE SKID STEER « HIGH FLOW » SYSTEM.

Pass through the guide located on the side of the skid steer hitch the three hoses with quick couplers and the 14 pin electric connector. Then connect them to the skid steer «high flow» system.

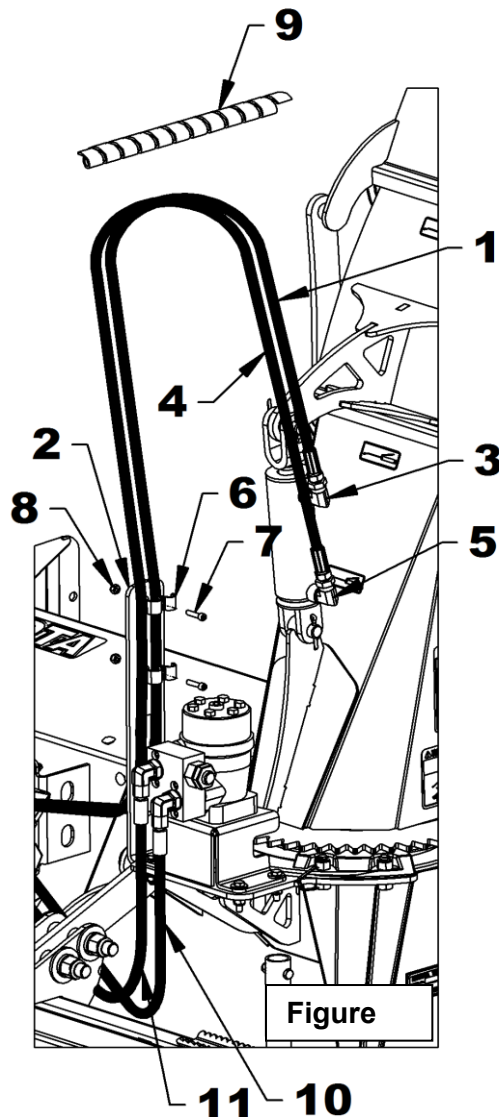
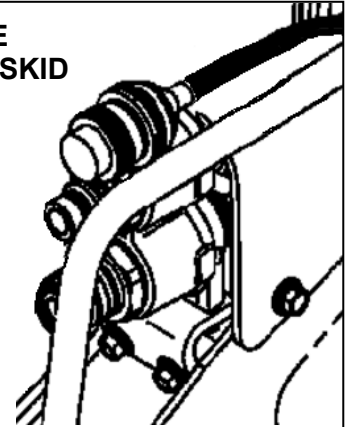

Figure

OPERATION

 **CAUTION:** THIS IS A HIGH FLOW SNOWBLOWER, LOW FLOW WILL RESULT IN POOR PERFORMANCE.

Optimum Performances

IMPORTANT: The hydraulic motors of the snowblower must have a breaking in period. If it is not respected, the warranty could be voided. The breaking in period must follow these steps:

- 1- 15-30 minutes of operation without any load and at half speed (vehicle RPM around 1250).
- 2- Check for unusual noises coming from the motors. If everything sounds normal, the load and engine speed can be increased.

Optimum snowblower performances are only achieved after 10 to 15 minutes of operation. It is therefore important to make certain that the hydraulic oil reaches a temperature over 40°C (104°F) before evaluating the performances.

The performance of the snowblower increases when the hydraulic pressure increases.

The higher the pressure, the higher the performance of the snowblower.

General Preparation

1. Read the operator's manual carefully before using the vehicle and snowblower. Be thoroughly familiar with the controls and proper use of the equipment. Know how to stop the unit and disengage the controls quickly.
2. Wear adequate winter outer garments while operating equipment.
3. Make sure the snowblower is clear of snow before engaging the hydraulic system.
4. Make sure the auger and fan operate freely.
5. Adjust the skid shoes so the snowblower runs level.
6. To obtain optimum performances of the snowblower, the oil in the hydraulic system must be warmed up for 10 to 15 minutes.

Operating controls

See Figures & Connection Chart on next page.

Hydraulic Deflector Adjustment

IMPORTANT: The snowblower drive system must be engaged to move the hydraulic deflector.

To adjust the angle of the deflector:

- push the switch down (item 1) to LOWER the deflector
- push the switch up (item 2) to RAISE the deflector.

If the operation is not as described, reverse the switch wires.

Hydraulic Rotation Adjustment

IMPORTANT: The snowblower drive system must be engaged to rotate the hydraulic chute.

To rotate the chute:

- push the switch (item 3) to turn the chute LEFT (counterclockwise)
- push the switch (item 4) to turn the chute RIGHT (clockwise)

If the operation is not as described, reverse the switch wires.



DANGER: To avoid serious injuries: Keep clear of rotating parts. Do not put hands or feet under, or into snowblower with engine running.

Park the vehicle/snowblower on level ground, place the transmission in neutral, set the parking brake, disengage the equipment drive, lower the equipment to the ground, place all control levers in neutral, shut off the engine, remove the ignition key and allow the rotating parts to stop **BEFORE** unclogging the collector/fan housing or chute, and making any repairs, adjustments or inspections. Use only a 36" long piece of wood to unclog blower.

Not respecting these instructions can result in serious injuries.

CONNEXION CHART

REF. No.	Pin Port	REMARKS
1	C	DEFLECTOR - LOWER
2	D	DEFLECTOR - RAISE
3	E	ROTATION - LEFT
4	F	ROTATION - RIGHT

[Standard model]

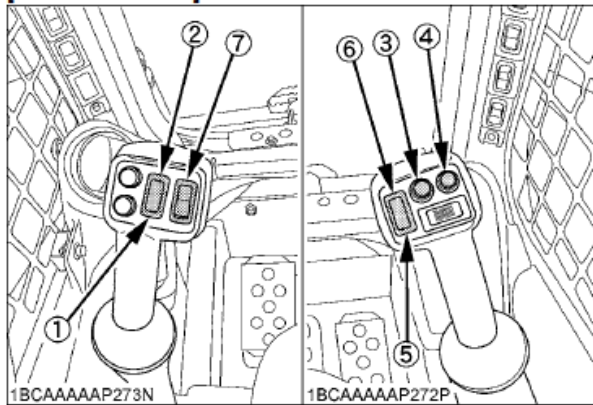

[ISO control model]

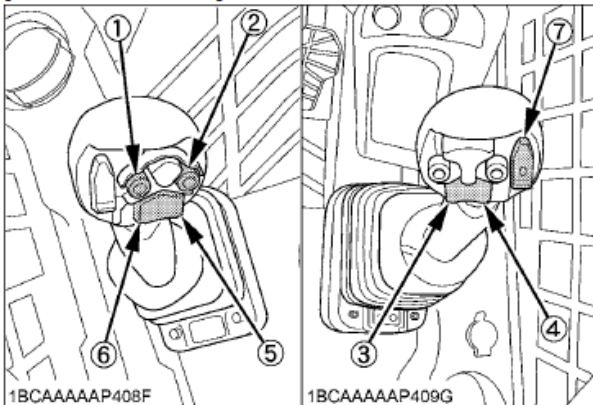

Ground Speed

Ground speed will depend on the thickness and density of the snow to be cleared away. Normally, ground speed will range from 4 to 7 MPH for light, dry snow 3 to 6 inches thick, and 1 to 3 MPH for heavy, wet or icy snow. To transport, disengage the hydraulic system and raise the snowblower to a reasonable height.

Skid Shoes Adjustment

Adjust the snowblower so that the skid shoes run level. Adjust the skid shoes according to the surface conditions so that stones are not thrown with the snow and adjust upwards for smooth surfaces. Adjust both skid shoes to the same height to keep the cutting edge level.

To adjust skid shoes, remove the pin and do the following adjustment:

Clearance between cutting edge and surface:

- **Level paved surface:** Adjust to 1/16" to 1/8"
- **Uneven or gravel surface:** Adjust to 1/2" and more according to size of gravel

IMPORTANT: The fan and auger are driven directly by hydraulic motors. Relief valves have replaced the shear bolts.

When an object blocks the fan or the auger, they stop turning. They start turning again when the object is removed.



DANGER: To avoid serious injuries: Keep clear of rotating parts. Do not put hands or feet under, or into snowblower with engine running.

Park the vehicle/snowblower on level ground, place the transmission in neutral, set the parking brake, disengage the equipment drive, lower the equipment to the ground, place all control levers in neutral, shut off the engine, remove the ignition key and allow the rotating parts to stop **BEFORE** unclogging the collector/fan housing or chute, and making any repairs, adjustments or inspections. Use only a 36" long piece of wood to unclog blower.

Not respecting these instructions can result in serious injuries.

SNOW REMOVAL METHODS

When removing snow, do not use the snowblower as a dozer blade to push snow. Let the snowblower work its way through deep drifts. If the travel speed is too fast, the snowblower may become overloaded and clog. For best results, raise the snowblower and remove a top layer of snow. A second pass with the snowblower will remove the remaining snow.

IMPORTANT: Use full RPM power when removing wet, sticky snow. Low RPM power will tend to clog the chute.



WARNING: To avoid serious personal injury: Do not use hands or feet to unclog chute. Do not attempt to clear clogged chute of snow while vehicle engine is running. If the chute clogs, disengage the drive shaft, shut off the vehicle engine, remove the ignition key, wait for all movement to stop, and then clear the snow from the chute.

A definite pattern of operation is required to thoroughly clean the snow area. These patterns will avoid throwing snow in unwanted places as well as eliminating a second removal of snow

PATTERN 1

DISCHARGE SNOW BOTH SIDES

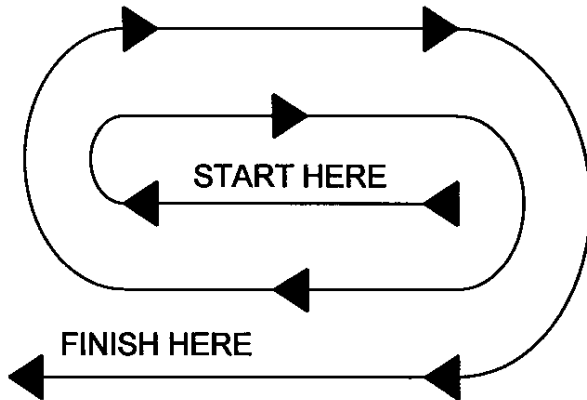

DISCHARGE SNOW BOTH SIDES

Where it is possible to throw the snow to the left and right (above), as on a long driveway, it is advantageous to start in the middle. Plow from one end to the other, throwing snow to both sides without changing the direction of the discharge guide.

PATTERN 2

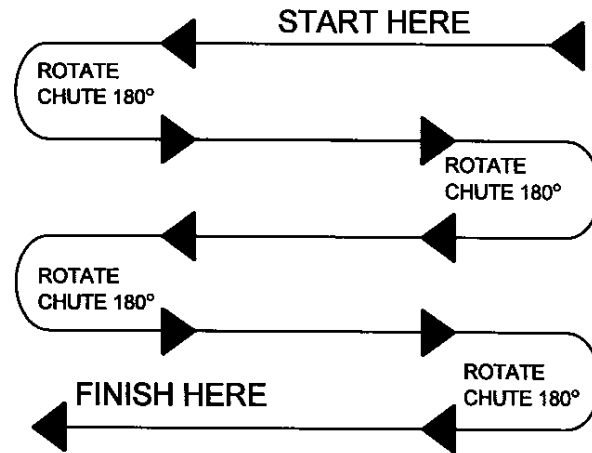

DISCHARGE SNOW THIS SIDE ONLY

If the snow can only be thrown to one side of the driveway or sidewalk (above), start on the opposite side. At the end of the first pass, rotate the discharge guide 180 degrees for the return pass. At the end of each succeeding pass, rotate the discharge guide 180 degrees to maintain direction of throw in the same area.

MAINTENANCE

ALWAYS USE GENUINE PARTS WHEN REPLACEMENT PARTS ARE REQUIRED

1. Check hardware at regular intervals to ensure it is always tightened properly.
2. Never park the vehicle inside a building where an open flame or sparks are present. Allow the engine to cool down before storing in any enclosure.
3. Run the snowblower a few minutes after blowing snow to prevent freeze up of the auger and fan.



WARNING: Provide adequate blocking before working under the snowblower when in raised position.

Hydraulic Oil

Check oil level before each use. Refer to the operation's manual of the vehicle.



WARNING: Escaping hydraulic/diesel fluid under pressure can penetrate the skin causing severe injuries.

- Do not use your hands to check for leaks. Use a piece of cardboard or paper to search for leaks.

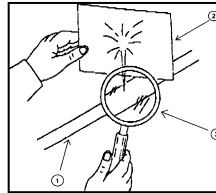
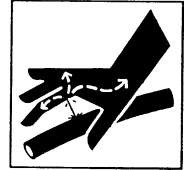

1. Hydraulic hose
2. Cardboard
3. Magnifying glass

- Shut engine off and relieve pressure before connecting or disconnecting lines.
- Tighten all connections before starting engine or pressurizing lines.
- If any fluid is injected into the skin, obtain medical attention immediately or gangrene may result.

LUBRICATION

Use a grease gun and lubricate as follows:

DESCRIPTION	INTERVAL	LUBRICATION REQUIRED
Bearing	24 hours of use	Grease the auger bearing
Chute	24 hours of use	Grease the pivot points on each side of the chute.

REGULAR INSPECTION

DESCRIPTION	INTERVAL	INSPECTION REQUIRED
Flow restrictors (items 1)	50 hours of use	Check that the hole is not obstructed
	200 hours of use	Replace with the appropriate hole size
Hoses	At each lubrication	Check for leaks
Hydraulic motor	At each lubrication	Check for leaks
Hydraulic block	At each lubrication	Check for leaks
Skid shoes / Cutting edge	100 hours of use	Check for wear and change if needed
Housing / Fan/Auger	100 hours of use	Repair if needed
Hardware	24 hours of use	Check and tighten if needed

LUBRICATION

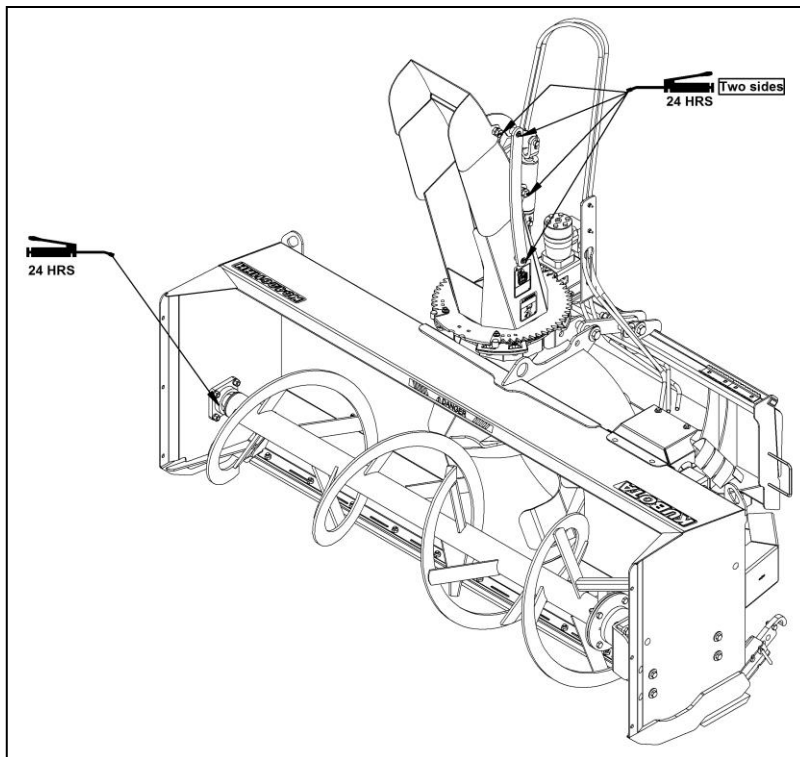

REGULAR INSPECTIONS

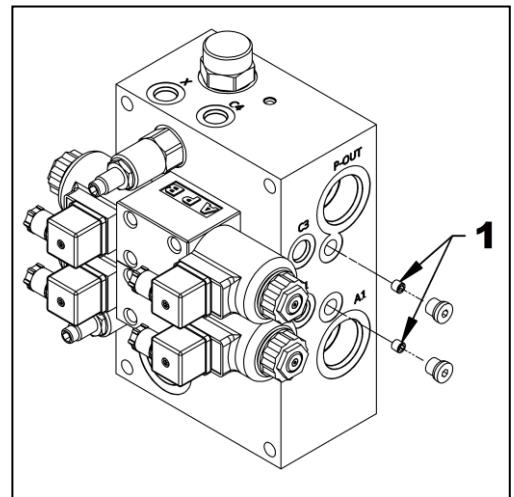

Instruction For Valve Adjustment

NOTE: Adjustments must be done without charge on the snowblower

Figure 15: FOR K842611HH ONLY : Before adjusting valves, remove the manifold guard (item 1) by removing four 5/16"NC x 3/4" carriage bolts (item 2), two 5/16" x 3/4" hex bolts (item 3), six 5/16" flat washers (item 4), six 5/16" lockwashers (item 5) and six 5/16" hex nuts (item 5).

A - Auger Motor valve (item A, fig.16)

1. **Figure 16:** Remove the two hydraulic hoses of the auger motor, that are connect port A1 and B1 of the manifold (items 1 & 2) and the fittings (items 3 & 4).

WARNING: Escaping hydraulic/diesel fluid under pressure can penetrate the skin causing severe injuries.

- Do not use your hands to check for leaks. Use a piece of cardboard or paper to search for leaks.

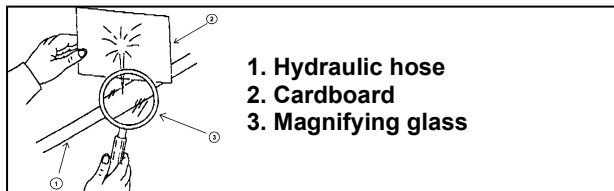
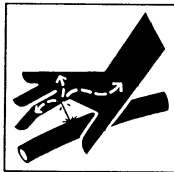

- Shut engine off and relieve pressure before connecting or disconnecting lines.
- Tighten all connections before starting engine or pressurizing lines.
- If any fluid is injected into the skin, obtain medical attention immediately or gangrene may result.

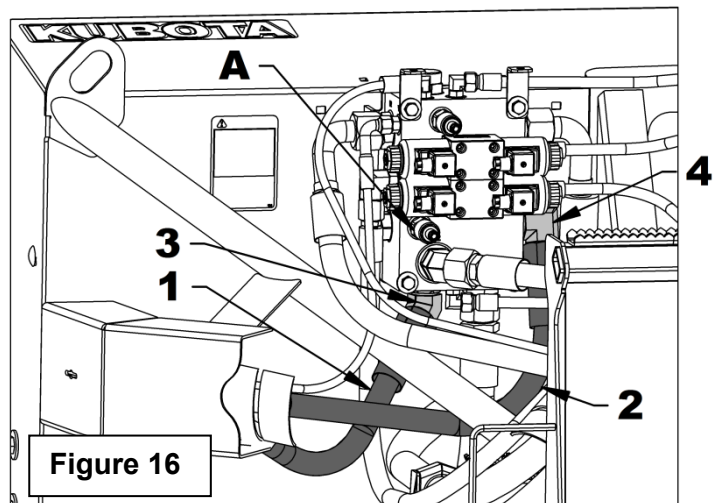
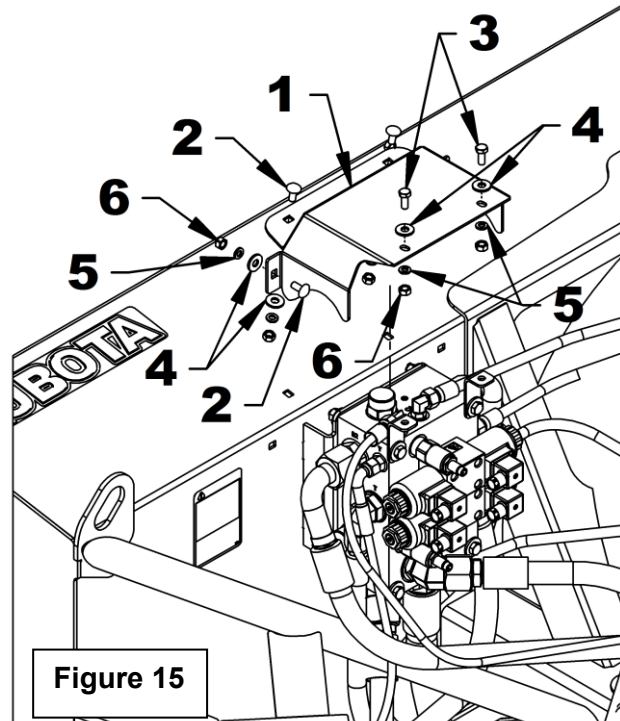

2. **Figure 17:** Install two 1 5/16" ORB hydraulic plug (item 1) to replace hoses previously removed.
3. **Figure 18:** Remove the hydraulic plug of port 1 (item 1) and install a pressure gauge.
4. Run the vehicle engine at idle and engage the hydraulic system. Check the pressure on gauge. It should be around **3000 psi**. If not, adjust pressure.

Figure 18: PRESSURE ADJUSTMENT of item A, turn clockwise to increase and counterclockwise to decrease.

5. **Figure 19:** Reinstall the hydraulic hoses and fittings (items 1, 2, 3, 4) of the auger motor as the original setting of the manifold.
6. Remove the pressure gauge and reinstall the plug previously removed (item 1, figure 18).

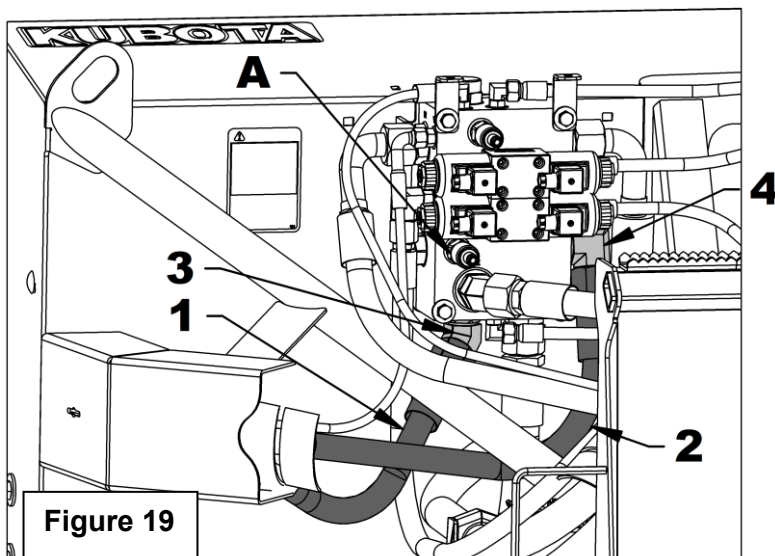
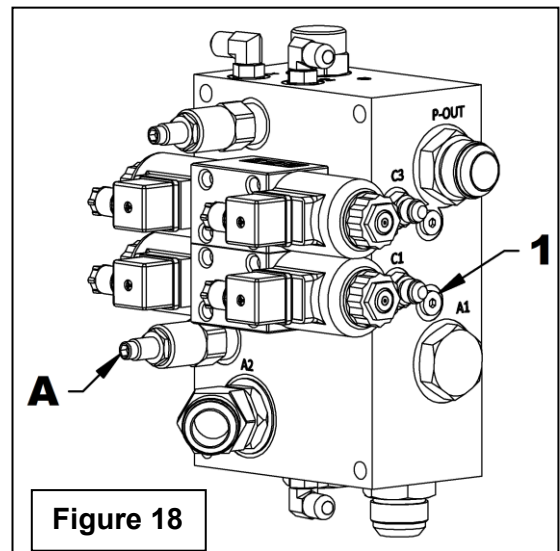
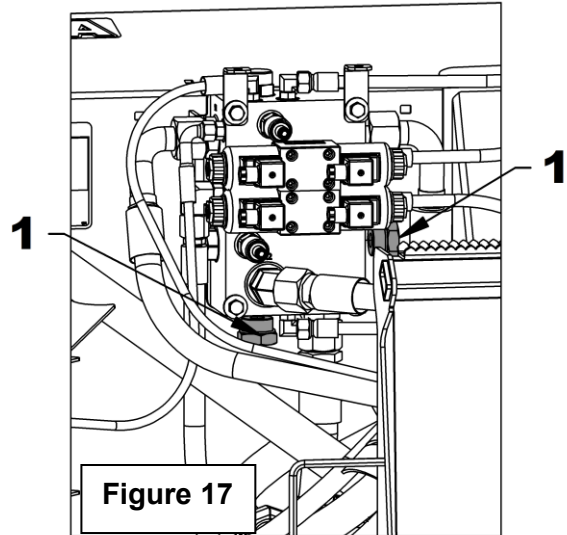

B -Impeller Motor valve (fig.6, item B)

1. **Figure 20:** Remove the two hydraulic hoses of the impeller motor, that are connected on port A2 and B2 of the manifold (items 1 and 2) and the fittings (items 3 and 4).
2. **Figure 21:** Install two 1 5/16" ORB hydraulic plugs (items 1) to replace hoses previously removed.
3. **Figure 22:** Remove the hydraulic hose connected in port B1 (item 1), install a "T" fitting (item 2) in B1 port and plug the hydraulic hose and the pressure gage on the fitting.
4. Run the vehicle engine at idle and engage the hydraulic system Check the pressure on gauge. It should be around **3000 psi** If not, adjust pressure.

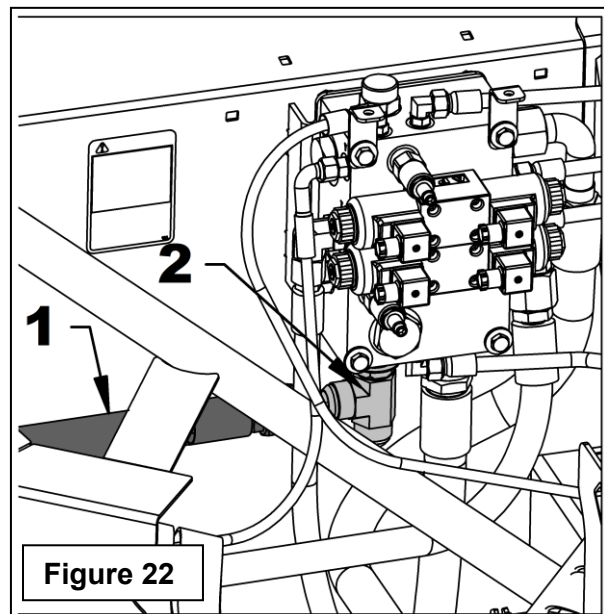
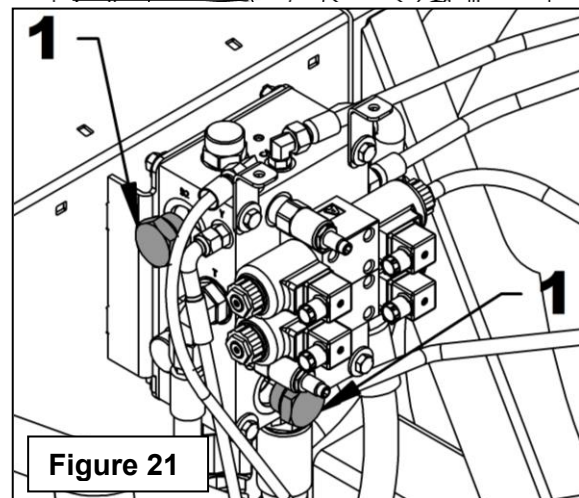
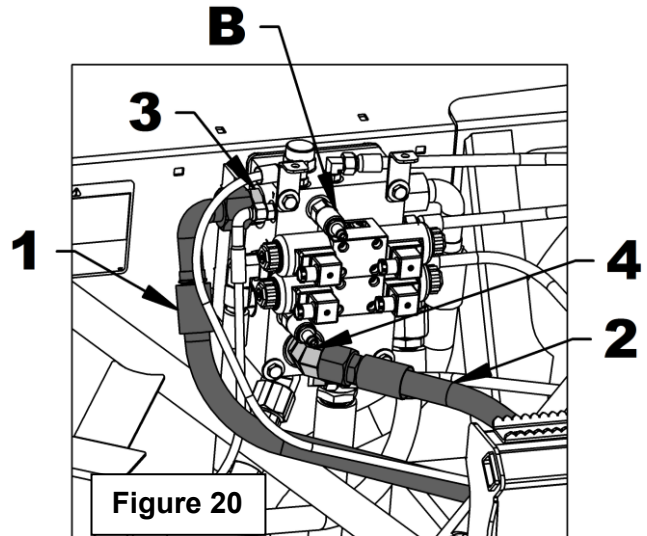

WARNING: Escaping hydraulic/diesel fluid under pressure can penetrate the skin causing severe injuries.

- Do not use your hands to check for leaks. Use a piece of cardboard or paper to search for leaks.

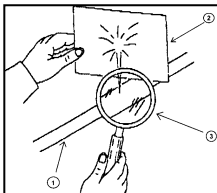
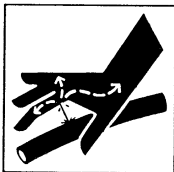

1. Hydraulic hose
2. Cardboard
3. Magnifying glass

- Shut engine off and relieve pressure before connecting or disconnecting lines.
- Tighten all connections before starting engine or pressurizing lines.
- If any fluid is injected into the skin, obtain medical attention immediately or gangrene may result.

5. **Figure 22: PRESSURE ADJUSTMENT** of item B, turn clockwise to increase and counterclockwise to decrease.
6. **Figure 23:** Reinstall the hydraulic hoses and fittings (items 1, 2, 3 and 4) of the impeller motor as the original setting of the manifold.
7. Remove the pressure gauge, and the hose (item 1, fig. 8) of the "T" fitting (item 2, fig. 8). Remove the "T" fitting of the manifold and reinstall the hose.

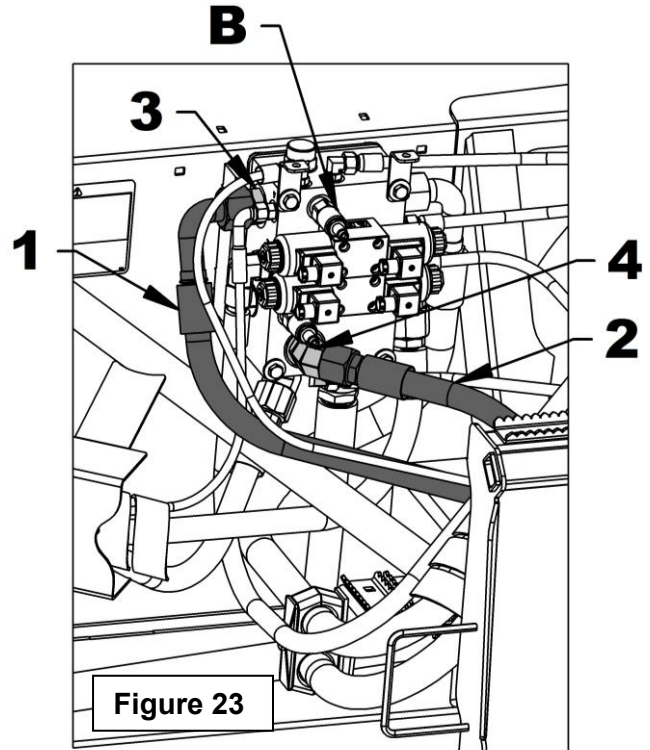
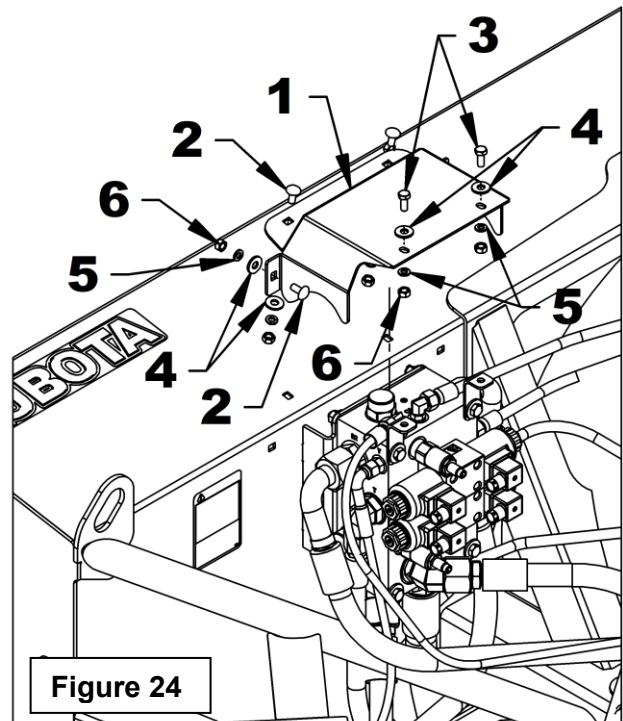
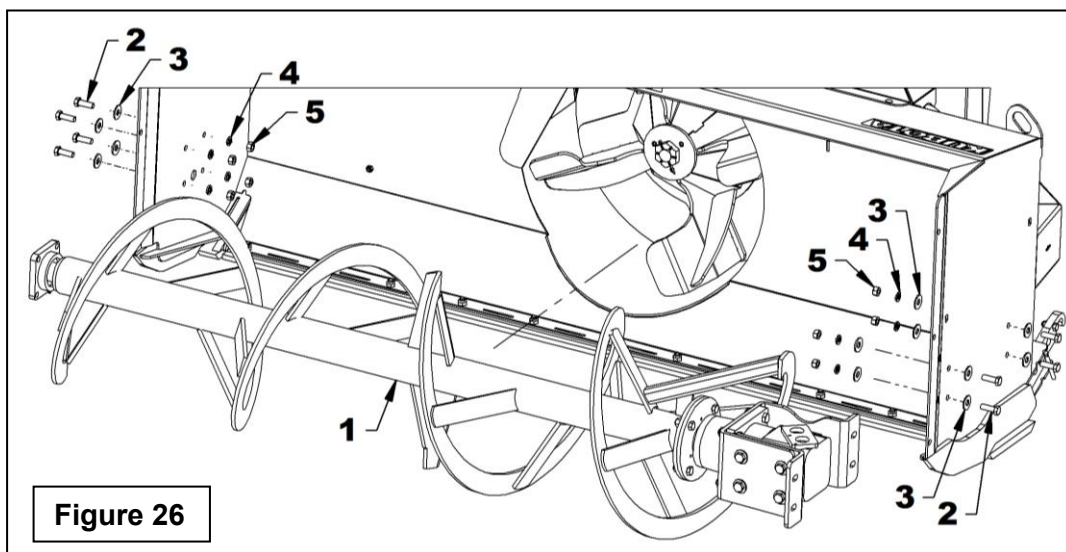
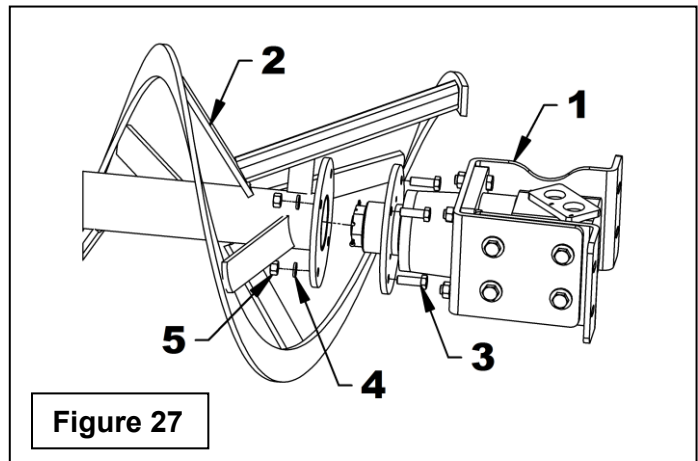
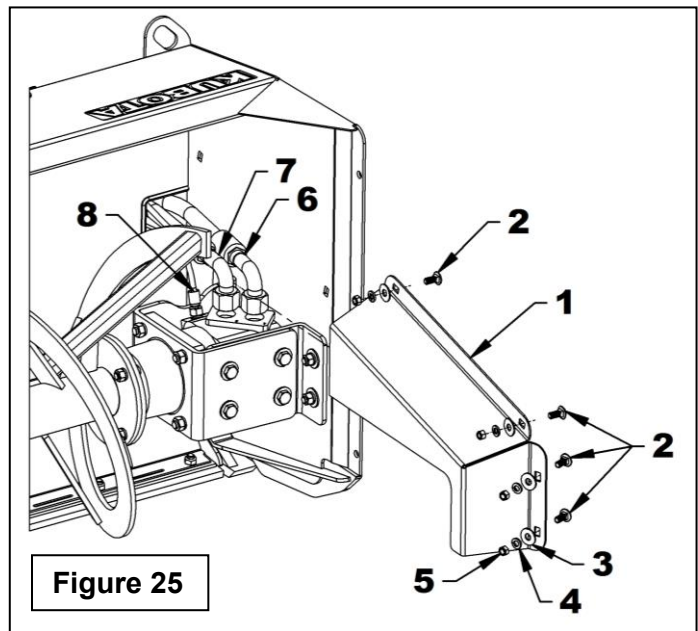

Figure 24: FOR K842611HH ONLY : After adjusting valves, reinstall the manifold guard (item 1) with four 5/16" NC x 3/4" carriage bolts (item 2), two 5/16" x 3/4" hex bolts (item 3), six 5/16" flat washers (item 4), six 5/16" lockwashers (item 5) and six 5/16" hex nuts (item 5).



Instruction to Take Off the Motor Adaptor of the Auger

1. **Figure 25:** Remove the hoses guard (item 1) by removing four 7/16"NC x 1 1/4" carriage bolt (item 2), four 7/16" flat washers (item 3), four 7/16" lockwashers (item 4) and four 7/16" nylon insert lock nuts (item 5).
2. **Figure 25:** Disconnect the hoses on the hydraulic motor of the auger (items 6, 7 & 8).
3. **Figure 26:** Remove the auger assembly (item 1) by removing the eight 1/2" x 1 1/2" hex bolts (item 2), twelve 1/2" flat washers (item 3), eight 1/2" lockwashers (item 4) and eight 1/2" hex nuts (item 5).
4. **Figure 27:** Remove the hydraulic motor and his adaptor (item 1) from the auger (item 2) by removing four 1/2" x 1 1/2" hex bolts (item 3), four 1/2" lockwashers (item 4) and four 1/2" hex nuts (item 5).
5. **Figure 28:** Remove the motor adaptor (item 1) from the hydraulic motor (item 2) by removing the 5/32" x 3" cotter pin (item 3) and the 1 1/4" – 18 UNEF castle nut (item 4).



6. **Figure 28:** If the motor adaptor (item 1) is blocked in the shaft of the hydraulic motor (item 2), remove it using three 3/8"NC by at least 1 1/4" long bolts (item 5) and screwing them a little one after the other so that they push evenly on the hydraulic motor therefore the motor adaptor will remove while remaining as straight as possible.

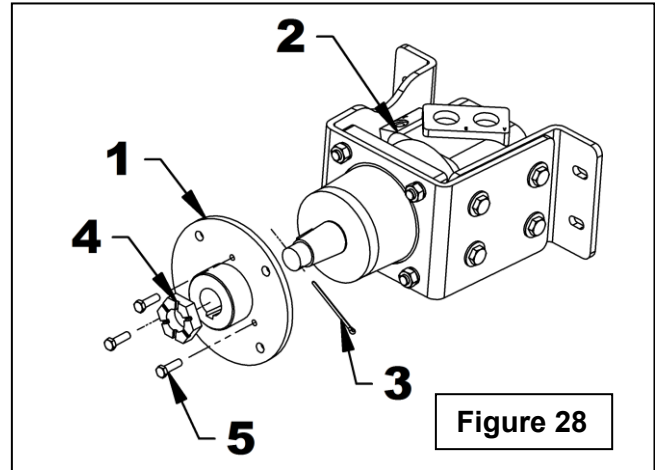

Instruction to Take Off the Impeller

1. Remove the hose guard, the hoses and the auger. See step 1 to 3 of the preceding section *Instruction to take off the motor adaptor of the auger*.
2. **Figure 29:** Remove the impeller (item 1) from the hydraulic motor (item 2) by removing the 5/32" x 3" cotter pin (item 3) and the 1 1/4" - 18 UNEF castle nut (item 4).
3. **Figure 29:** If the impeller (item 1) is blocked on the shaft of the hydraulic motor (item 2), remove first the three 1/2"NC x 7/8" allen set screws (item 5) that are installed on the impeller and then, use three 3/8"NC by at least 2 3/4" long bolts (item 6) by screwing them a little one after the other so that they push on the hydraulic motor evenly therefore the impeller will remove while remaining as straight as possible. Screw back on the impeller the three allen socket head cap screws (item 5) previously removed.

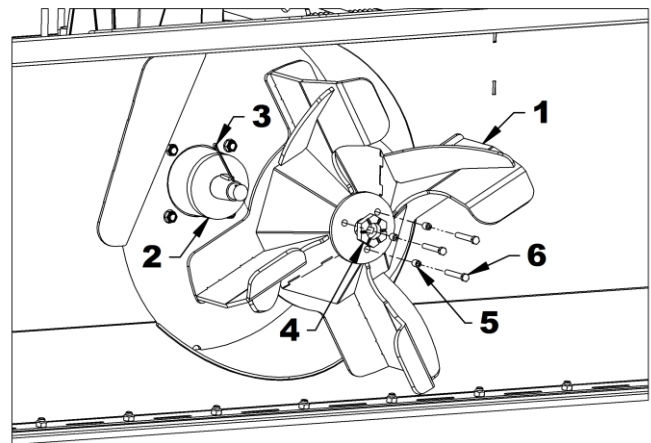

STORAGE

Before storing the snowblower, certain precautions should be taken to protect it from deterioration.

1. Clean the snowblower thoroughly.
2. Make all the necessary repairs.
3. Replace all safety signs that are damaged, lost, or otherwise become illegible. If a part to be replaced has a label on it, obtain a new safety label from your dealer and install it in the same place as on the removed part.
4. Repaint all parts from which paint has worn or peeled.
5. Lubricate the snowblower as instructed under "**Lubrication**" section.
6. When the snowblower is dry, oil all moving parts. Apply oil liberally to all surfaces to protect against rust.
7. Store in a dry place.

TROUBLESHOOTING

Optimum Performance

IMPORTANT: The optimum performances of the snowblower are only achieved after 10 to 15 minutes of snowblower operation. It is therefore important to ensure that the hydraulic oil reaches a temperature of over 40°C (104°F) before judging the snowblower's performances.

The performance of the snowblower increases when the hydraulic pressure increases. The higher the pressure, the higher the performance of the snowblower.

The following chart serves as a guide in case of a malfunction. If the problem is not solved after taking the appropriate corrective measure, contact your dealer.

⚠ WARNING: Several corrective measures present a certain risk, which may cause serious injuries or death.

Only a qualified person, familiar with the risks associated with hydraulics, electricity and machinery should perform the repairs. Review the safety precautions at the beginning of this manual.

⚠ WARNING: Hot engine parts and hydraulic oil can cause serious burns. Always let the engine cool before proceeding with repairs or maintenance.

⚠ CAUTION: The oil temperature must never go above 65°C (149°F) to avoid damages to the hydraulic components.

PROBLEM	CORRECTIVE MEASURE
The auger and fan do not turn	<ul style="list-style-type: none"> • Check if an object is blocking the fan or auger • Check for oil leaks • Check hydraulic oil level and add some if needed • Check that the input and output hoses are connected • Check that the input and output hoses are in the right position, if not reverse their position • Check if the flow restrictor is obstructed and replace if needed
The auger and fan are turning in reverse	<ul style="list-style-type: none"> • Check that the hoses are connected correctly to the hydraulic manifold and reverse their position if necessary
The snow is not being ejected from the chute	<ul style="list-style-type: none"> • Check if the fan is turning, refer to problem # 1 • Check if the fan is turning in the right direction, refer to problem # 2 • Check if the snow output is obstructed, unclog with a 36" stick
The snowblower clogs up easily	<ul style="list-style-type: none"> • Check the viscosity of the hydraulic oil • Check hydraulic oil level and add some if needed • Check if the vehicle engine is at full RPM • Check the hydraulic pressure of the system • Check the hydraulic flow of the system • Check if the flow restrictor is obstructed and replace if needed • Check if the sequence valve is working and adjust or replace if needed

PROBLEM	CORRECTIVE MEASURE
Snow doesn't enter the snowblower properly	<ul style="list-style-type: none"> • Check the viscosity of the hydraulic oil • Check hydraulic oil level and add some if needed • Check if the vehicle engine is at full RPM • Check hydraulic pressure • Check hydraulic flow • Check is the flow restrictor is worn and replace if needed • Check the motor and auger relief valve • Check if the sequence valve is working and adjust or replace if needed
The snow is not thrown very far	<ul style="list-style-type: none"> • The engine is not at full RPM • Check hydraulic oil level and add some if needed • Check hydraulic pressure, adjust if too low • Check hydraulic flow • Reduce the ground speed (Refer to Operation section) • Check the hoses for leaks, replace if needed • Check if the flow restrictor is obstructed and replace if needed • Check the motor and fan relief valve • The sequence valve is not adjusted properly, adjust or replace if needed
The chute's hydraulic rotation or deflector does not operate	<ul style="list-style-type: none"> • Check if the snowblower is engaged • Check if the attachment flow restrictor is obstructed, replace if needed • Check if the hoses and wires are connected properly
The chute's hydraulic rotation or deflector is working, but in an erratic way	<ul style="list-style-type: none"> • The engine is not at full RPM • Check for dirt in the oil and replace if needed • Check if the hoses and wires are connected properly • Check if the attachments flow restrictor is obstructed, replace if needed
The hydraulic motor of the auger and/or fan and/or hydraulic rotation leaks oil from the shaft	<ul style="list-style-type: none"> • Check that the maximum hydraulic pressure is below the allowable level • Check that the maximum return pressure is below the allowable level • Check that the hydraulic motors relief valve is operating properly • Replace the motor seals • Replace the motor

PARTS

MANUAL HOLDER

REF.	PART #	QTY	DESCRIPTION	CODE
010	77700-01998	1	Manual holder	4200030
020	75599-01215	2	Hex bolt. 5/16" NC x 3/4" Lg Gr.5, Plated	0100018
030	75599-31912	2	Nylon insert locknut 5/16"NC, Plated	1000005

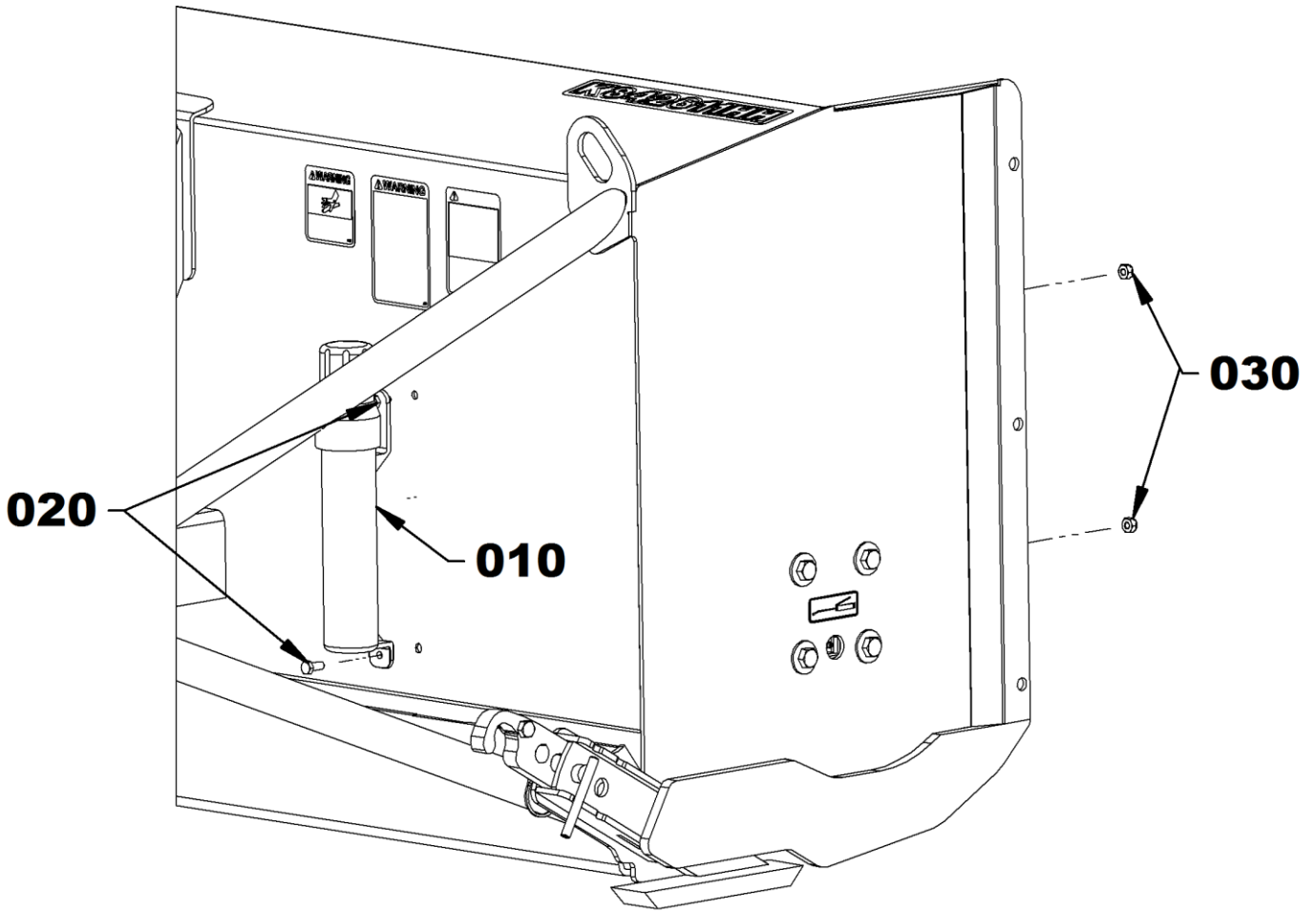

THREE PART CHUTE

REF.	QTY	DESCRIPTION	PART#
010	1	Chute base black	672740
020	1	Middle deflector black	672739
030	1	Upper deflector black	672738
040	2	Deflector lateral arm black	672741
050	4	Retaining plate	670933
060	4	Chute guide	670944
070	2	Anti-friction plate	671608
080	1	Cylinder ø2" x 5"	665433
090	1	- Seal kit	665434
100	2	- Pin ø3/4" x 2 1/2"	665235
110	4	- Cotter pin 3/16" x 1 1/2"	1500013
120	2	Stopper	671611
130	2	Elbow 90° 3/8"NPT M x 3/8"NPT SWF	654557
140	4	Anti-friction plate	671609
150	4	Hinge bolt	671610
160	4	Grease fitting 1/4"NF	654106
170	4	Lockwasher 5/8" Plated	1200007
180	4	Grease fitting 1/8"NPT	656493
190	4	Flat washer 10mM Plated	1400019
200	4	Plastic bushing	4300124
210	2	Carriage bolt 5/16"NC x 1" Plated	0300003
220	2	Flat washer 5/16" (3/8" int) Plated	1400003
230	2	Nylon insert locknut 5/16"NC Plated	1000005
240	8	Hex bolt 1/2"NC x 1 1/2" Gr.5, Plated	0100070
250	8	Lockwasher 1/2" Plated	1200006
260	8	Nylon insert locknut 1/2"NC Plated	1000011
270	2	Low profile socket head cap screw 1/4"NC x 3/4" Plated	0800059
280	2	Lockwasher 1/4" Plated	1200002
290	2	Hex. nut 1/4"NC Plated	0900001

76" SNOWBLOWER ASSEMBLY - FRONT

REF.	QTY	DESCRIPTION	PART#
010	1	Housing 76" snowblower	672674
020	1	Fan – 4 blades ø24"	672673
030	1	Auger	672675
040	1	Cutting edge	669306
050	1	Left hose guard	672681
060	1	Motor support	672871
070	1	Adjustable motor support	672872
080	1	Driving hub	672524
090	1	Hydraulic motor 500 cc – shaft 1:8 45 mm	3910120
100	1	- Seal kit	3910121
110	2	Castle nut 1 1/4"-18 UNEF	1100037
120	1	Flange bearing 1 1/4" hole	4300118
130	9	Plow bolt 1/2"NC x 1 1/2" Gr.5, Plated	0400006
140	9	Stover lock nut 1/2"NC Plated	1100006
150	12	Hex. bolt 1/2"NC x 1 1/2" Gr.5, Plated	0100070
160	20	Flat washer 1/2" (9/16" int) Plated	1400006
170	16	Lockwasher 1/2" Plated	1200006
180	16	Hex.nut 1/2"-13NC	0900006
190	4	Hex. bolt 1/2"NC x 1 3/4" Gr.5, Plated	0100071
200	4	Hex. bolt 5/16" NC x 1" Gr.5, Plated	0100019
210	8	Flat washer 1/4" (int 5/16") Plated	1400002
220	4	Lockwasher 5/16" Plated	1200003
230	4	Hex nut 5/16"-18 Plated	0900002
240	4	Hex. bolt 14mm x 2.00 x 50mm Lg. Gr.10.9 Plated	0200140
250	4	Lockwasher 14mm Plated	1200014
260	4	Hex. nut 14mm x 2.00 Plated	0900055
270	1	Cotter pin 5/32" x 3"	1500033
280	3	Allen socket head cap screw 1/2"NC x 7/8"	0500033
290	6	Shim for hydraulic motor	672752

76" SNOWBLOWER ASSEMBLY - FRONT

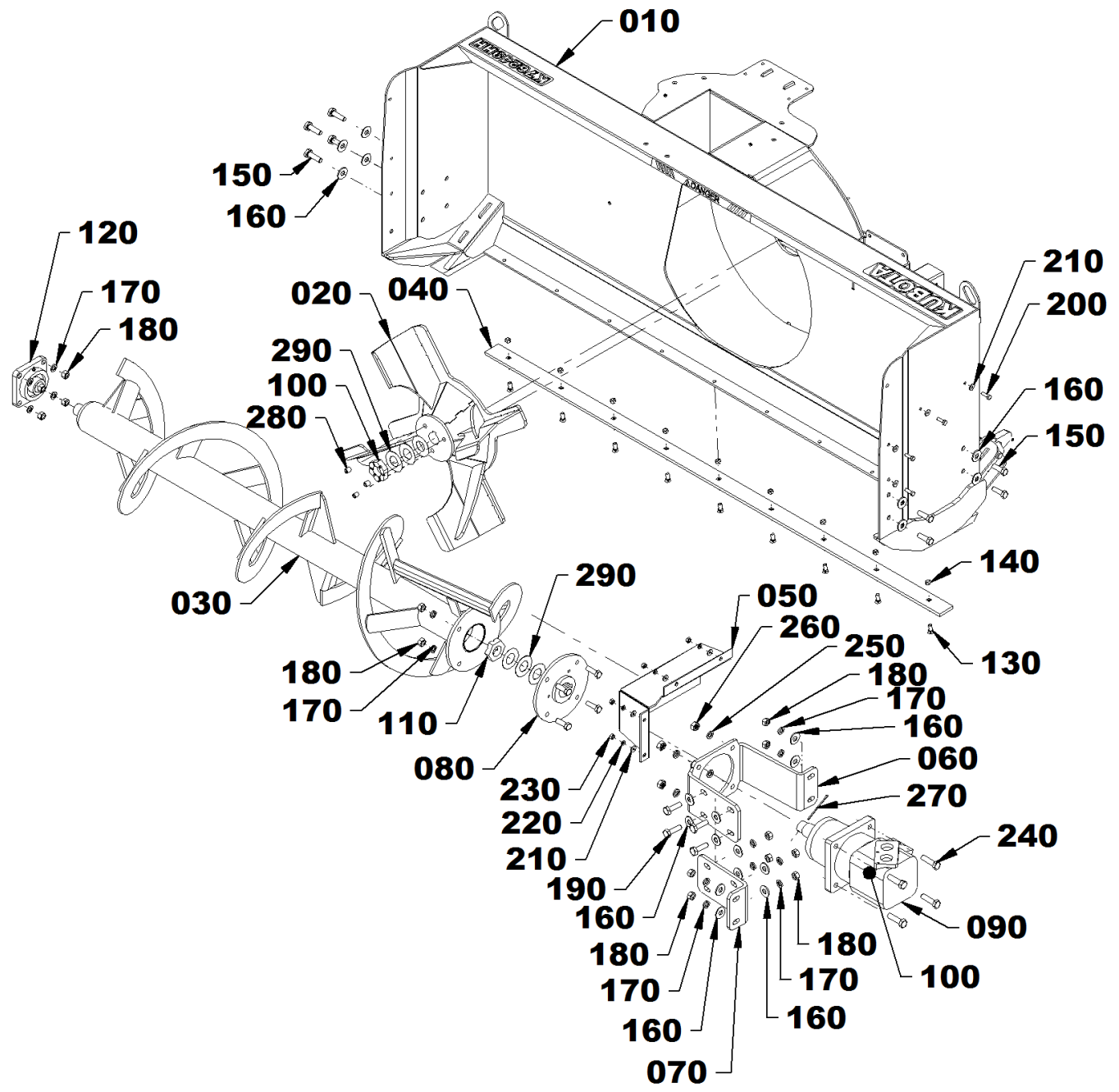

84" SNOWBLOWER ASSEMBLY - FRONT

REF.	QTY	DESCRIPTION	PART#
010	1	Housing 84" snowblower	672296
020	1	Fan – 4 blades ø26"	672279
030	1	Auger	672295
040	1	Cutting edge	672297
050	1	Left hose guard	672281
060	1	Motor support	672874
070	1	Adjustable motor support	672875
080	1	Driving hub	672524
090	1	Hydraulic motor 500 cc – shaft 1:8 45 mm	3910120
100	1	- Seal kit	3910121
110	2	Castle nut 1 1/4"-18 UNEF	1100037
120	1	Flange bearing 1 1/4" hole	4300001
130	11	Plow bolt 1/2"NC x 1 1/2" Gr.5, Plated	0400006
140	11	Stover lock nut 1/2"NC Plated	1100006
150	12	Hex. bolt 1/2"NC x 1 1/2" Gr.5, Plated	0100070
160	20	Flat washer 1/2" (9/16" int) Plated	1400006
170	16	Lockwasher 1/2" Plated	1200006
180	16	Hex. nut 1/2"-13NC	0900006
190	4	Hex. bolt 1/2"NC x 1 3/4" Gr.5, Plated	0100071
200	4	Carriage bolt 7/16"NC x 1" Gr.5, Plated	0300018
210	4	Flat washer 7/16" (1/2" int) Plated	1400005
220	4	Lockwasher 7/16" Plated	1200005
230	4	Nylon insert locknut 7/16"-14NC	1000009
240	4	Hex. bolt 14mm x 2.00 x 50mm Lg. Gr.10.9 Plated	0200140
250	4	Lockwasher 14mm Plated	1200014
260	4	Hex. nut 14mm x 2.00 Plated	0900055
270	1	Cotter pin 5/32" x 3"	1500033
280	3	Allen set screw 1/2" NC x 7/8" Gr.5, Plated	0500033
290	6	Shim for hydraulic motor	672752

84" SNOWBLOWER ASSEMBLY - FRONT

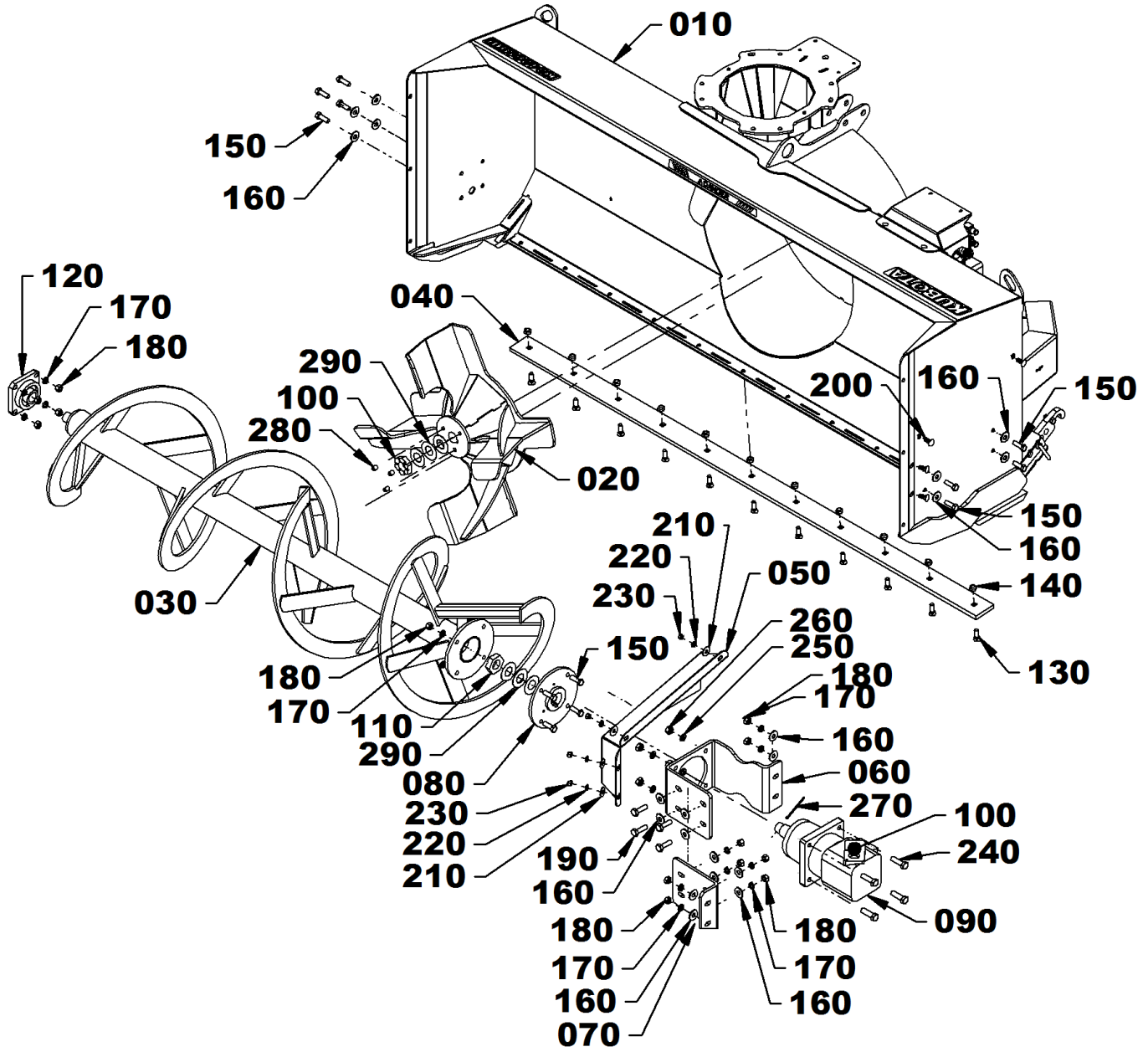

84" SNOWBLOWER ASSEMBLY - REAR

REF.	QTY	DESCRIPTION	PART#
010	1	Left skid shoe	671694
020	1	Right skid shoe	671695
030	1	Parking stand	668091
040	1	Hydraulic block protector	672283
050	1	Hydraulic motor 200cc – shaft 1:8 45mm	3910119
060	1	- Seal kit	3910121
070	2	"L" Pin 3/4" x 2 5/16" Plated	671696
080	2	Round wire lock pin 1/4" Plated	1900006
090	2	Hex bolt. 7/16"NC x 1 1/4" Gr.5, Plated	0100057
100	2	Nylon insert locknut 7/16"-14NC	1000009
110	1	Wire lock pin 3/8" x 2 1/2" square	1900008
120	1	Hex bolt 5/16"NC x 1 3/4" Gr.5, Plated	0100022
130	1	Nylon insert locknut 5/16"-18NC	1000005
140	4	Carriage bolt 5/16" x 3/4"NC Gr.5	0300002
150	6	Flat washer 5/16" (3/8" int) Plated	1400003
160	6	Lockwasher 5/16" Plated	1200003
170	6	Hex. nut 5/16"NC Plated	0900002
180	2	Hex bolt. 5/16" NC x 3/4" Gr.5, Plated	0100018
190	4	Hex bolt. M14 x 2.00 x 55mm Plated	0200135
200	4	Lockwasher M14 Plated	1200014
210	1	Cotter pin 5/32" x 3"	1500033
220	1	Hex bolt. 5/16" NC x 2 1/2" Gr.5, Plated	0100026
230	1	Tightening plate – double hose support 38mm	4200074
240	1	Double hose plastic clamp 38mm (2 parts)	4200073

84" SNOWBLOWER ASSEMBLY - REAR

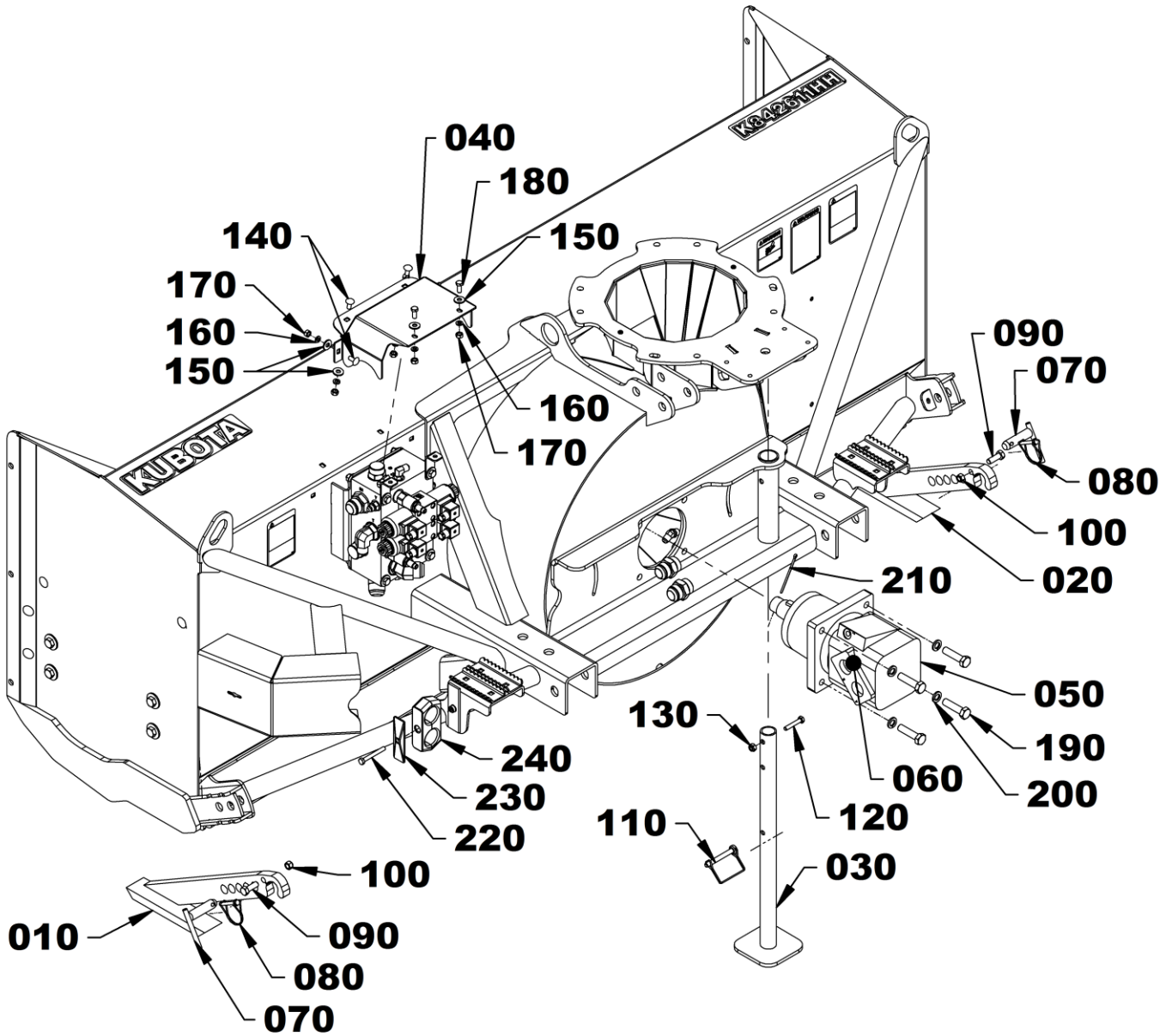

76" SNOWBLOWER ASSEMBLY - REAR

REF.	QTY	DESCRIPTION	PART#
010	1	Left skid shoe	669020
020	1	Right skid shoe	669021
030	1	Hydraulic motor 200cc – shaft 1:8_45mm	3910119
040	1	- Seal kit	3910121
050	2	Pin 3/4" x 3 13/16" bent Plated	667899
060	2	Round wire lock pin 1/4", Plated	1900006
070	2	Spring pin 3/8" x 2"	1600024
080	4	Hex bolt. 12 mm x 1.75 x 50 Lg. Plated	0200033
090	4	Flat washer 12 mm Plated	1400030
100	4	Nylon insert locknut 12 mm x 1.75	1000022
110	1	Cotter pin 5/32" x 3" Plated	1500033

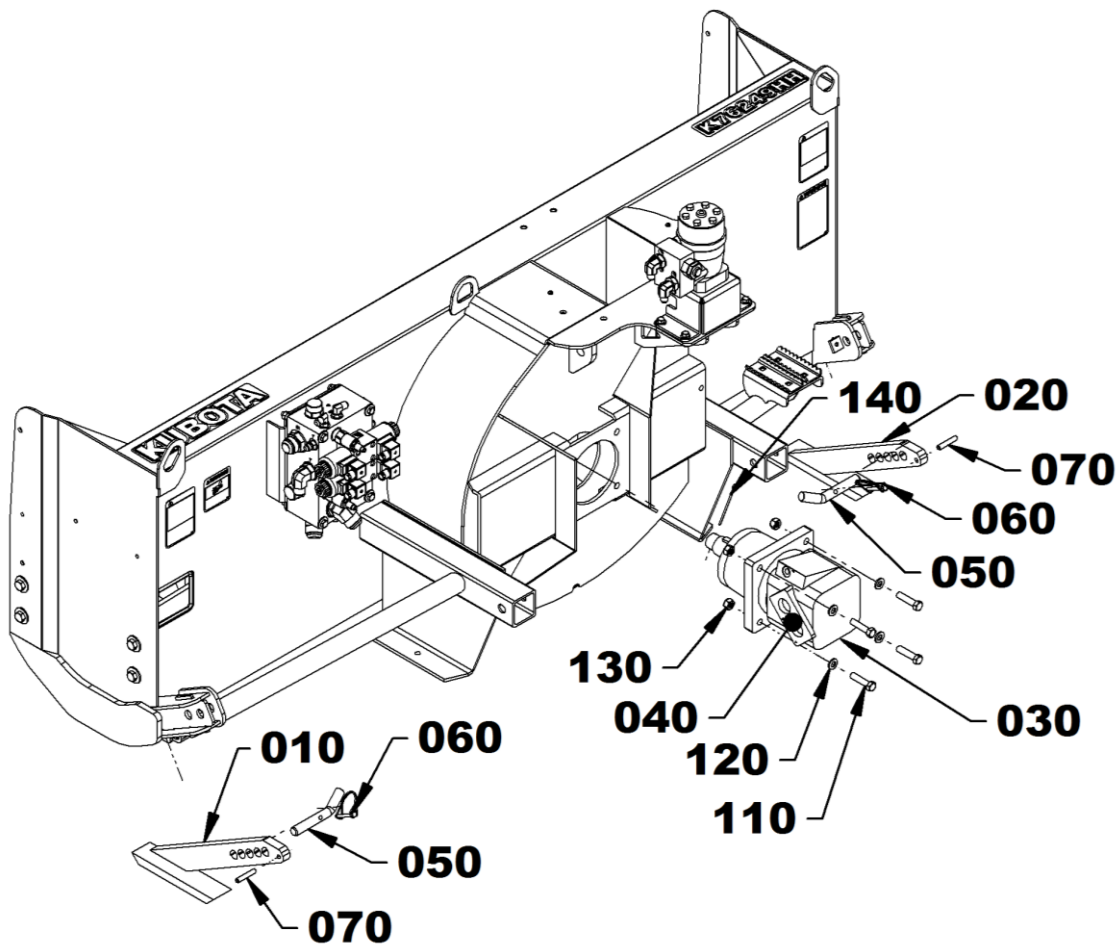

HITCH FOR 76" SNOWBLOWER

REF.	QTY	DESCRIPTION	PART#
010	1	Hitch for snowblower - skid steer	671600
020	1	Upper hitch	671601
030	1	Hose support	671612
040	2	Hex. bolt 3/4" NC x 5" Plated	0100126
050	2	Hex bolt 3/4" NC x 2 3/4" Gr.5, Plated	0100120
060	8	Flat washer 3/4" (13/16" int) Plated	1400028
070	4	Lock washer 3/4" Plated	1200008
080	4	Nylon insert locknut 3/4"NC Plated	1000013
090	2	Serrated flange bolt 3/8" NC x 1 1/4" Gr.5, Plated	0200079
100	2	Serrated flange nut 3/8" NC Plated	0900035
110	1	Double hose clamp 1/4" hose	670414
120	1	Allen socket head capscrew 1/4" x 1"NC Gr.5	0800007
130	1	Nylon insert locknut 1/4"NC Plated	1000003
140	1	Double hose plastic clamp 38mm (2 parts)	4200073
150	1	Tightening plate - double hose support	4200074
160	1	Hex. bolt 5/16"NC x 3 1/2" Gr.5 Plated	0100029
170	1	Flat washer 5/16" (3/8" int) Plated	1400003
180	1	Nylon insert locknut 5/16"NC Plated	1000005

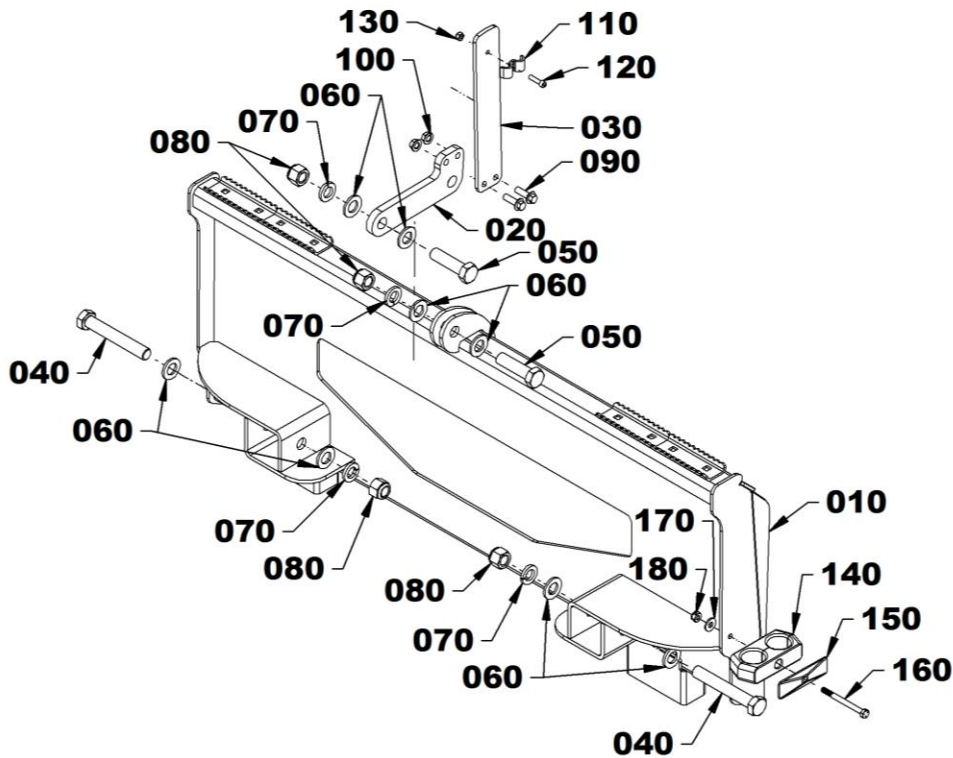

HITCH FOR 84" SNOWBLOWER

REF.	QTY	DESCRIPTION	PART#
010	1	Hitch for snowblower - skid steer	672284
020	1	Upper hitch	672546
030	2	Reinforcement plate	668117
040	6	Hex. bolt 3/4"NC x 5 1/2" Plated	0100127
050	3	Hex. bolt 3/4"NC x 5" Plated	0100126
060	18	Flat washer 3/4" (13/16" int)	1400010
070	9	Lockwasher 3/4" Plated	1200008
080	9	Nylon insert locknut 1/4"NC Plated	1000013

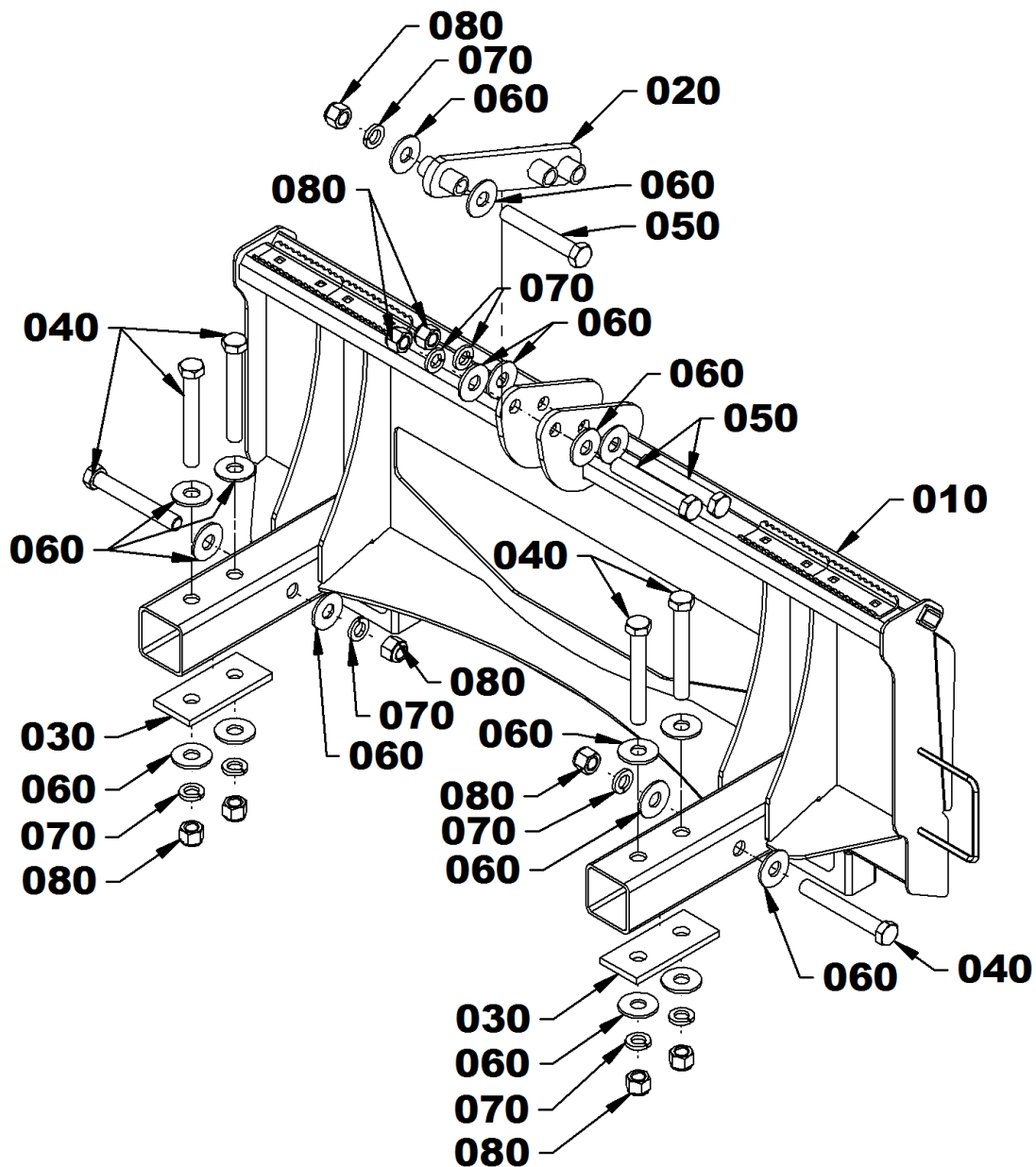

HYDRAULIC SYSTEM

REF.	QTY	DESCRIPTION	PART#
010	1	Hose \varnothing 1" x 108", 1 5/16" JIC SWF SHB90 x 3/4" NPTF M	3700341
020	1	Hose \varnothing 1" 94", 1 5/16" JIC SWF x 3/4" NPTF M	3700342
030	1	Hose \varnothing 1/2" x 99", 7/8" JIC SWF x 3/8" NPT M	3700370
040	1	Hose \varnothing 3/4" x 46", 1 5/16" JIC SWF shb90 x 1 5/16" JIC SWF	3700337
050	1	Hose \varnothing 3/4" x 36", 1 5/16" JIC SWF x 1 5/16" JIC SWF	3700338
060	1	Hose \varnothing 1/4" x 42", 9/16" JIC SWF shb90 x 9/16" JIC SWF	3700330
070	1	Hose \varnothing 3/4" x 37", 1 5/16" JIC SWF x 1 5/16" JIC SWF SHB90	3700354
080	1	Hose \varnothing 3/4" x 23", 1 5/16" JIC SWF x 1 5/16" JIC SWF	3700353
090	1	Hose \varnothing 1/4" x 42", 9/16" JIC SWF x 9/16" JIC SWF	3700331
100	1	Hose \varnothing 3/8" x 48", 9/16" JIC SWF x 9/16" JIC SWF	3700333
110	1	Hose \varnothing 3/8" x 51", 9/16" JIC SWF x 9/16" JIC SWF	3700334
120	1	Hose \varnothing 3/8" x 78", 9/16" JIC SWF x 3/8" NPT M	3700335
130	1	Hose \varnothing 3/8" x 81", 9/16" JIC SWF x 3/8" NPT M	3700332
140	7	Connector 1 5/16" ORB M x 1 5/16" JIC M	2600265
150	2	Elbow 45° 1 5/16" JIC M x 1 5/16" ORB M	2600270
160	1	Elbow 90° 1 5/16" ORB M x 1 5/16" JIC M	2600266
170	1	Elbow 90° 7/8" JIC M x 3/4" ORB M	2600104
180	3	Elbow 90° 9/16" JIC M x 9/16" ORB M	2600147
190	5	Connector 7/16" ORB M x 9/16" JIC M	2600112
200	1	Protector, black plastic \varnothing 5/8" to 1" x 15"	671428
210	3	Protector, black plastic \varnothing 1 5/8" to 1 7/8" x 10"	669154
220	1	Female quick coupler "flat face" 3/4"NPT	2600263
230	1	Male quick coupler "flat face" 3/4"NPT	2600264
240	1	Female quick coupler "flat face" 3/8"NPT	2600252

HYDRAULIC SYSTEM

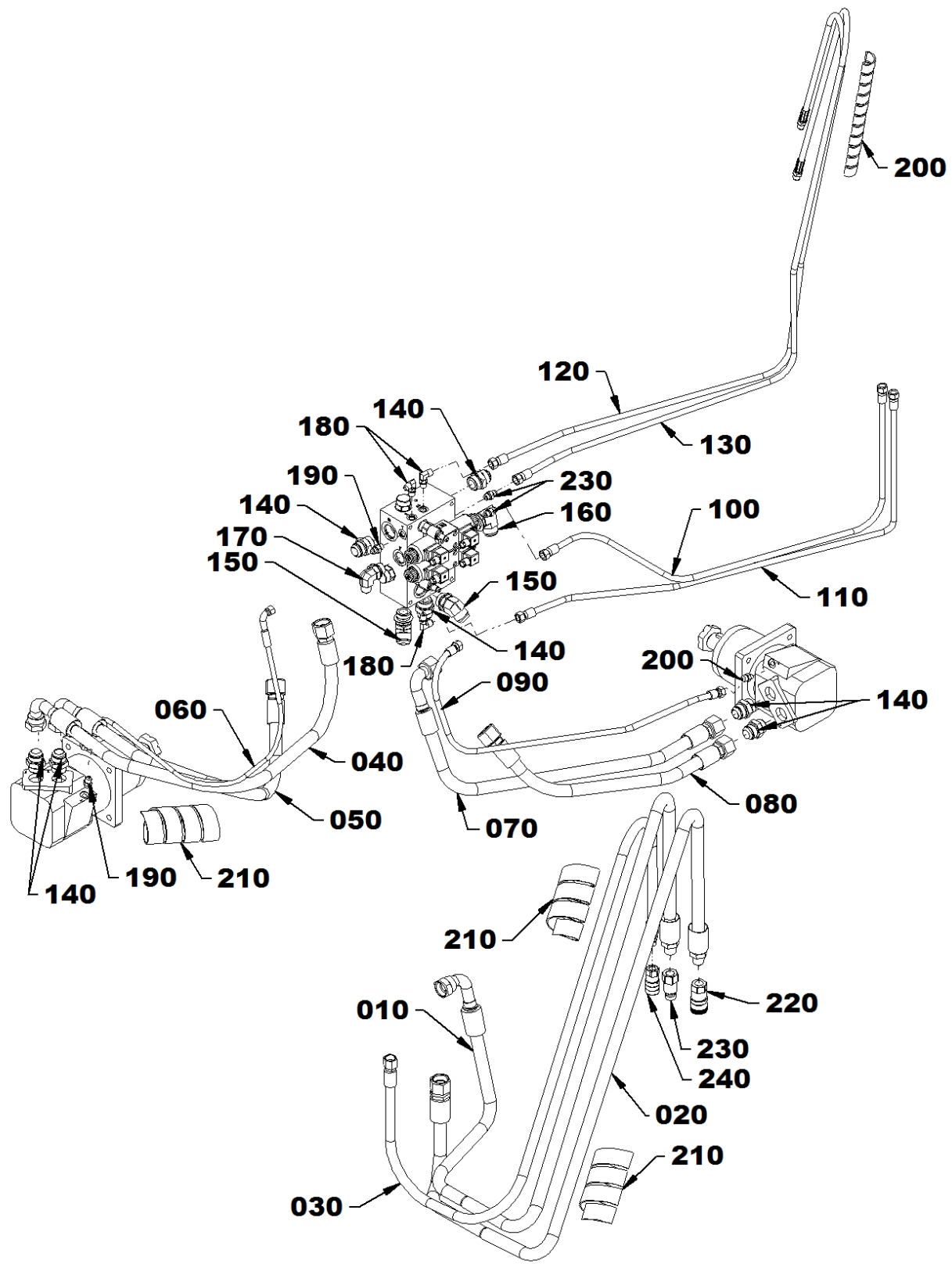

HYDRAULIC MOTOR

REF.	QTY	DESCRIPTION	PART#
010	1	Gear shield	671602
020	1	Hose support – 84” Snowblower	672280
030	1	Hydraulic Motor 160cc w/ valve adjusted at 1600 psi (incl. #040 to 070, & 090)	3910023
040	1	- Key 1/4" x 1/4" x 1"	655379
050	1	- Seal kit	3910028
060	2	- O-ring 0.103" x 15/16" x 1 1/8"OD	3900463
070	1	- Crossover relief valve preset @ 1600 psi (incl.in 77700-07749)	3920031
080	2	90° elbow 7/8"ORB M x 9/16"JIC M	2600106
090	4	- Allen socket head cap screw 5/16"NC x 1 1/2" Gr.5	0800011
100	1	Motor gear	665930
110	1	Hex bolt 1/4"NC x 1" Gr.5, Plated	0100004
120	1	Lockwasher 1/4" Plated	1200002
130	1	Flat washer 1/4" (5/16" int) Plated	1400002
140	4	Hex bolt 3/8"NC x 3/4" Gr.5, Plated	0100037
150	4	Lockwasher 3/8" Plated	1200004
160	4	Hex bolt 5/16"NC x 1 1/2" Gr.5 Plated	0100021
170	8	Flat washer 5/16" (3/8" int)	1400003
180	4	Lockwasher 5/16" Plated	1200003
190	4	Nylon insert locknut 5/16"NC Plated	1000005
200	2	Hose clamp 1/4" double compact Plated – 84” Snowblower	670414
210	2	Allen socket head cap screw 1/4"NC x 1" Gr.5 – 84” Snowbl.	0800007
220	2	Nylon insert locknut 1/4"-20 Plated – 84” Snowblower	1000003

HYDRAULIC MOTOR

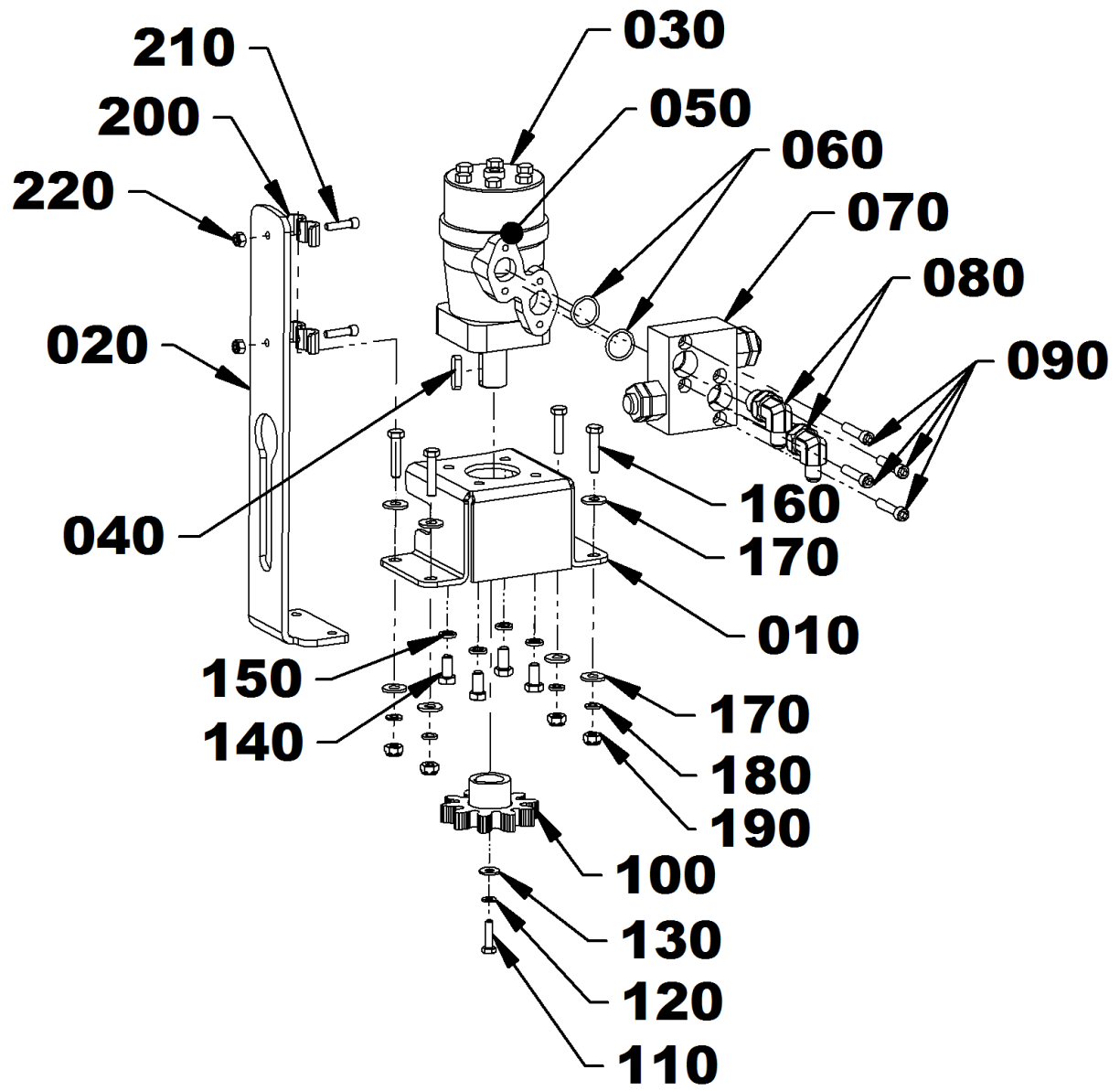

HYDRAULIC BLOCK

REF.	QTY	DESCRIPTION	PART#
010	1	Hydraulic manifold (incl. #030 to 090)	3920086
020	2	Reinforcement plate for hydraulic manifold guard	672287
030	2	- Vented valve	3900521
040	2	1. Seal kit	3900522
050	2	- Relief valve preset at 3000 psi	3900519
060	2	1. Seal kit	3900520
070	2	- Flow restrictor 0.0781", 1/16" NPT, Allen head	672667
080	2	- Hydraulic male plug 7/16" ORB M, Allen head	2600213
090	2	- Electro-hydraulic valve center-close	3900027
100	4	Connector DIN	4000062
110	8	Allen socket head cap screw 10-24 x 1 3/4" Gr.5	0800018
120	8	O-ring 0.07" x 3/8" x 1/2" OD	3900462
130	4	Bolt Hex. 3/8" NC x 4 1/2" Gr.5, Plated	0100050
140	8	Flat washer 3/8" Plated	1400004
150	4	Lockwasher 3/8" Plated	1200004
160	4	Nut hex. 3/8" Plated	0900003
170	1	Electric harness	4000189

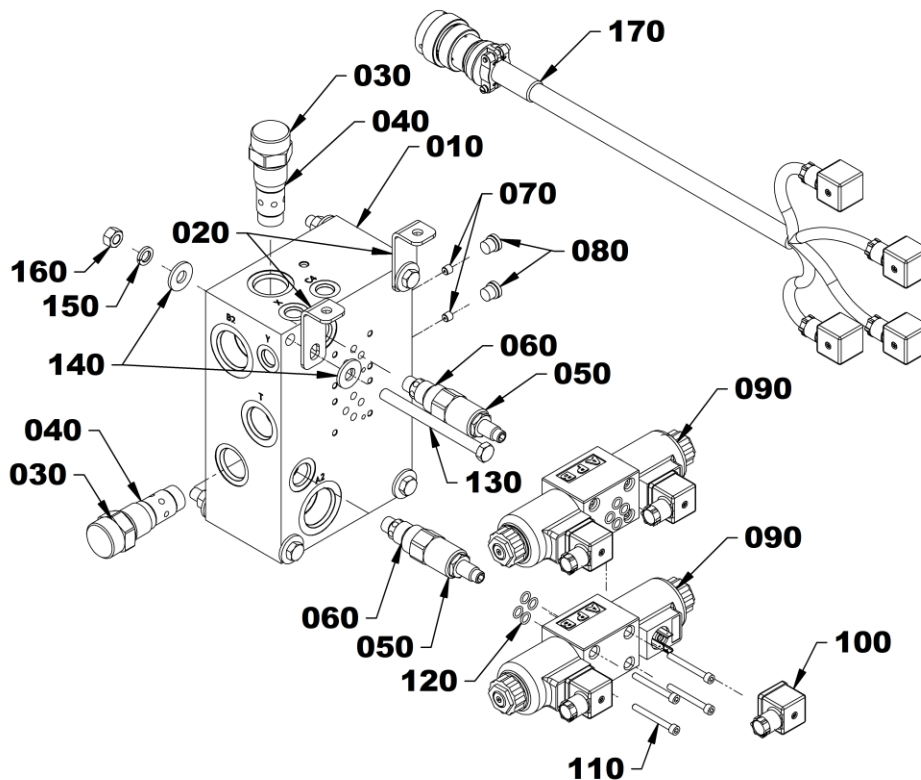

HYDRAULIC & ELECTRIC SCHEMATICS

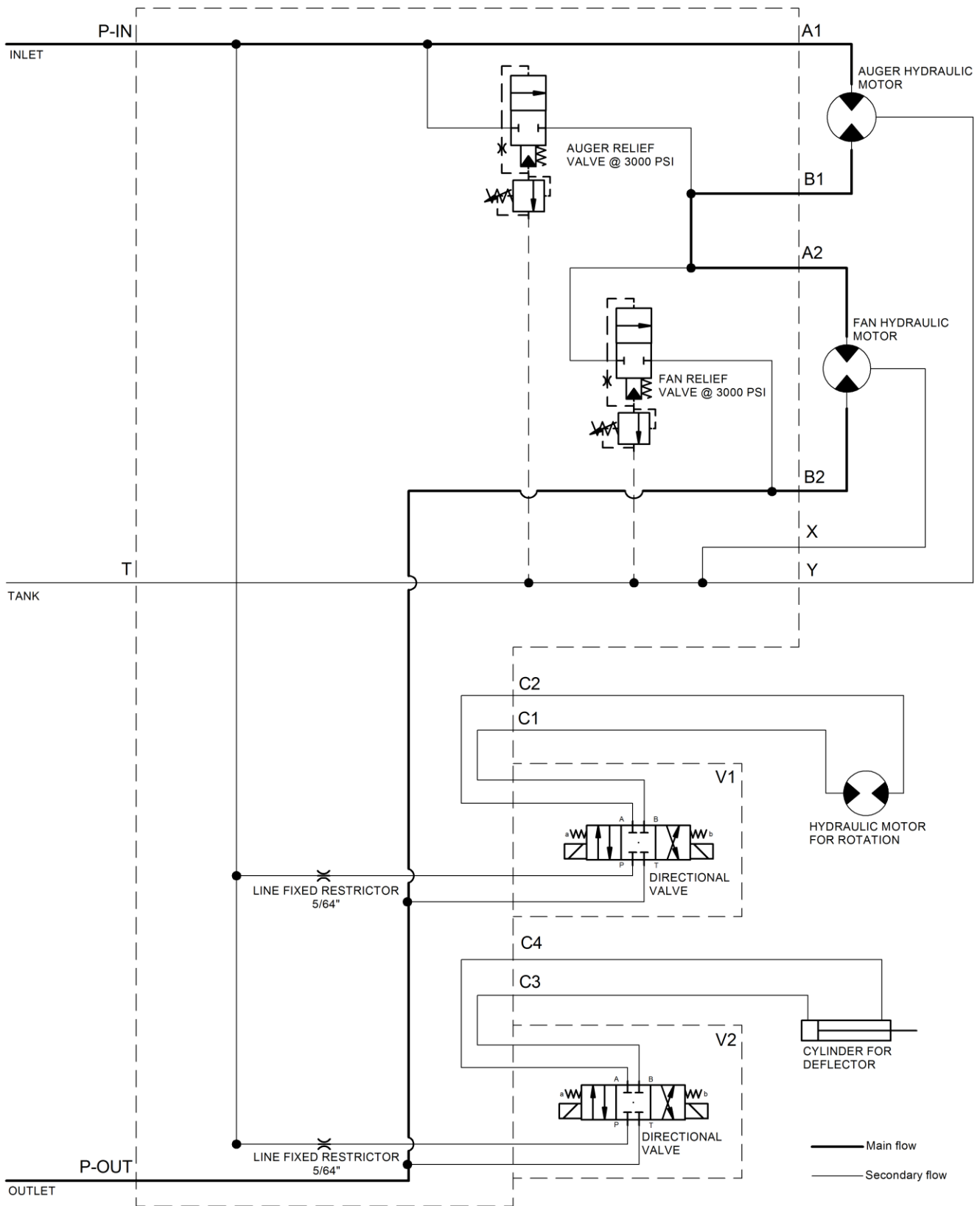

Hydraulic Diagram

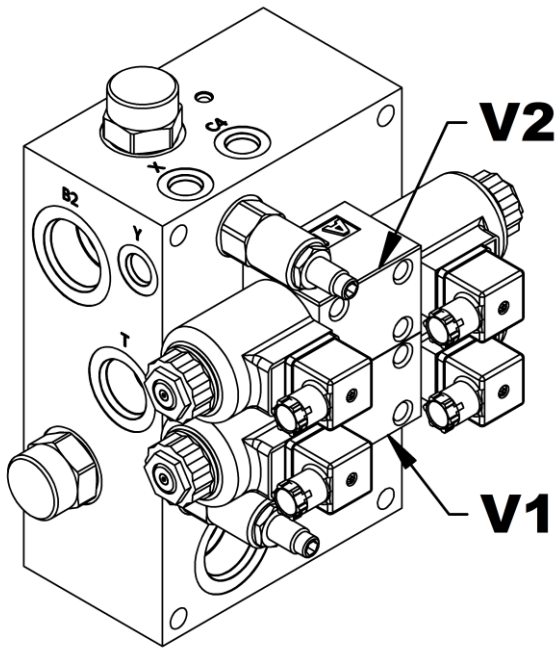

Electrical Diagram

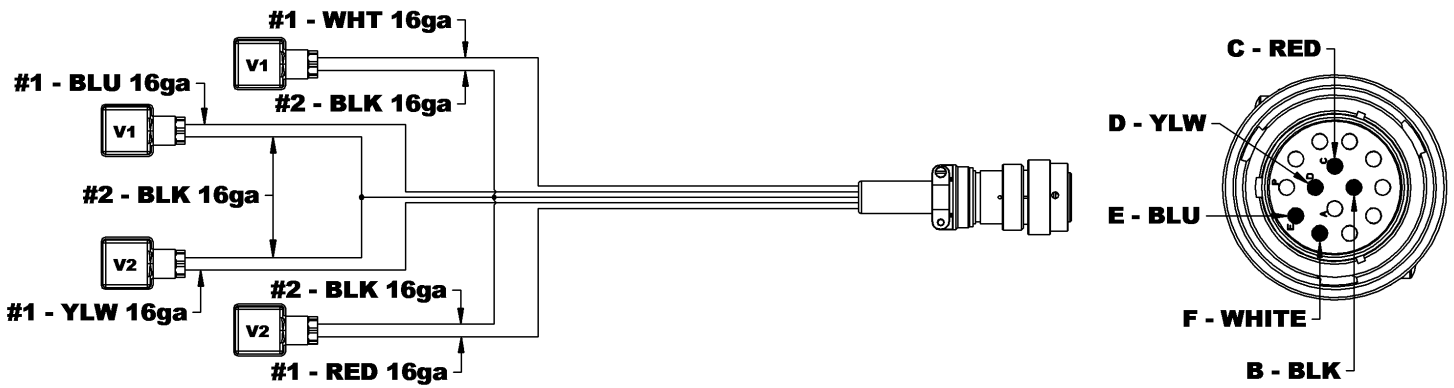







TORQUE SPECIFICATION TABLE

GENERAL SPECIFICATION TABLE

USE THE FOLLOWING TORQUES WHEN SPECIAL TORQUES ARE NOT GIVEN

Note: These values apply to fasteners as received from supplier dry, or when lubricated with normal engine oil. They do not apply if special graphited or moly sulphide greases or other extreme pressure lubricants are used. These values apply to dry conditions; under lubricated conditions reduce by 25% the torques in this table.

BOLT HEAD IDENTIFICATION

INCHES Bolt Size	 Grade 2		 Grade 5		 Grade 8		METRIC Bolt Size	 5.8 Class 5.8		 8.8 Class 8.8		 10.9 NP Class 10.9	
	in-tpi ¹	N-m ²	lbs-ft ³	N-m	lbs-ft	N-m		lbs-ft	mm.pitch ⁴	N-m	lbs-ft	N-m	lbs-ft
1/4" – 20NC	7.4	5.6	11	8	16	12	M 5 X 0.8	4	3	6	5	9	7
1/4" – 28NF	8.5	6	13	10	18	14	M 6 X 1	7	5	11	8	15	11
5/16" – 18NC	15	11	24	17	33	25	M 8 X 1.25	17	12	26	19	36	27
5/16" – 24NF	17	13	26	19	37	27	M 8 X 1	18	13	28	21	39	29
3/8" – 16NC	27	20	42	31	59	44	M10 X 1.5	33	24	52	39	72	53
3/8" – 24NF	31	22	47	35	67	49	M10 X 0.75	39	29	61	45	85	62
7/16" – 14NC	43	32	67	49	95	70	M12 X 1.75	58	42	91	67	125	93
7/16" – 20NF	49	36	75	55	105	78	M12 X 1.5	60	44	95	70	130	97
1/2" – 13NC	66	49	105	76	145	105	M12 X 1	90	66	105	77	145	105
1/2" – 20NF	75	55	115	85	165	120	M14 X 2	92	68	145	105	200	150
9/16" – 12NC	95	70	150	110	210	155	M14 X 1.5	99	73	155	115	215	160
9/16" – 18NF	105	79	165	120	235	170	M16 X 2	145	105	225	165	315	230
5/8" – 11NC	130	97	205	150	285	210	M16 X 1.5	155	115	240	180	335	245
5/8" – 18NF	150	110	230	170	325	240	M18 X 2.5	195	145	310	230	405	300
3/4" – 10NC	235	170	360	265	510	375	M18 X 1.5	220	165	350	260	485	355
3/4" – 16NF	260	190	405	295	570	420	M20 X 2.5	280	205	440	325	610	450
7/8" – 9NC	225	165	585	430	820	605	M20 X 1.5	310	230	650	480	900	665
7/8" – 14NF	250	185	640	475	905	670	M24 X 3	480	355	760	560	1050	780
1" – 8NC	340	250	875	645	1230	910	M24 X 2	525	390	830	610	1150	845
1" – 12NF	370	275	955	705	1350	995	M30 X 3.5	960	705	1510	1120	2100	1550
1 1/8" – 7NC	480	355	1080	795	1750	1290	M30 X 2	1060	785	1680	1240	2320	1710
1 1/8" – 12NF	540	395	1210	890	1960	1440	M36 X 3.5	1730	1270	2650	1950	3660	2700
1 1/4" – 7NC	680	500	1520	1120	2460	1820	M36 X 2	1880	1380	2960	2190	4100	3220
1 1/4" – 12NF	750	555	1680	1240	2730	2010							
1 3/8" – 6NC	890	655	1990	1470	3230	2380							
1 3/8" – 12NF	1010	745	2270	1670	3680	2710							
1 1/2" – 6NC	1180	870	2640	1950	4290	3160							
1 1/2" – 12NF	1330	980	2970	2190	4820	3560							

¹ in-tpi = nominal thread diameter in inches-threads per inch
² N-m = newton-meters
³ lbs-ft = pounds-foot
⁴ mm x pitch = nominal thread diameter in millimeters x thread Pitch

*Torque tolerance +0%, -15% of torquing values. Unless otherwise specified use torque values listed above

*NOTE: 1 lbs-ft = 12 lbs-in

ADAPTER INSTALLATION PROCESS

NPT THREAD IDENTIFICATION & TORQUE

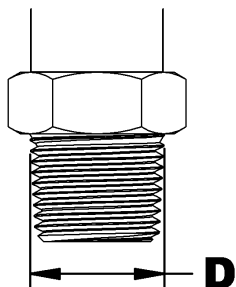

D		Identification of adapter	Number of turns to do after manual tightening
in	mm		
0.375	9.5	1/8 NPT	2.0 - 3.0
0.500	12.5	1/4 NPT	2.0 - 3.0
0.625	15.9	3/8 NPT	2.0 - 3.0
0.780	19.8	1/2 NPT	2.0 - 3.0
0.988	25.1	3/4 NPT	2.0 - 3.0
1.236	31.4	1 NPT	1.5 - 2.5
1.583	40.2	1 1/4 NPT	1.5 - 2.5
1.823	46.3	1 1/2 NPT	1.5 - 2.5

RECOMMENDED ASSEMBLY

The method used to assemble fittings with NPT threads is done in two stages. First firmly tighten by hand then tighten once again according to the number of turns listed in the above table. The following steps are recommended to minimize the risks of leaks and/or damages to the parts.

STEP 1: Inspect threads and tapping to make sure they are clean.

STEP 2: Measure the diameter (D) of the adapter and take note of the size taken.

STEP 3: Apply a sealant/lubricant product to the NPT threads (teflon covered threads are preferable to other lubricating products). If PTFE tape (teflon) is used, make between 1.5 or 2 turns clockwise, when viewed by the fitting end, keeping free the two first threads.

CAUTION: More than 2 turns can cause distortion or cracks in the orifice.

STEP 4: Tighten the fitting manually.

STEP 5: Screw the fitting the number of turns listed on the above table making sure that in the case of an elbow fitting the end is aligned to the desired position to connect the tube or hose. **Never unscrew a fitting to obtain the proper alignment.**

STEP 6: If a leak is detected after having followed the preceding instructions, check that the threads are not damaged and the number of seated threads is fulfilled (see details in next paragraph).

If the threads are damaged, replace the fitting. If the tapping is damaged, retap if possible or replace the part.

Usually, the number of threads seated is between 3.5 and 6. If the range is different it would indicate that the fitting was tightened too much or not enough or that the tightening was not within thread tolerances. If the fitting is not tight enough, tighten but never more than one turn. If it's too tight, control the threading and tapping and replace the section that has threads that are not within tolerances.

JIC THREAD IDENTIFICATION & TORQUE

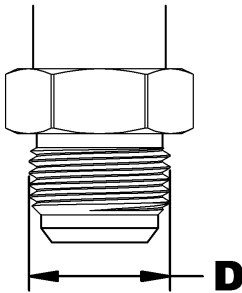

D		Identification of adapter	TORQUE	
in	mm		lbs-ft	N-m
-	-	5/16 JIC	6-7	8-10
-	-	3/8 JIC	6-9	8-12
0.433	11	7/16 JIC	9-12	12-16
0.496	12.6	1/2 JIC	14-15	19-21
0.559	14.2	9/16 JIC	18-20	24-27
0.740	18.8	3/4 JIC	27-39	37-53
0.870	22.1	7/8 JIC	36-63	49-85
1.055	26.8	1 1/16 JIC	65-88	88-119
1.185	30.1	1 3/16 JIC	75-103	102-140
1.307	33.2	1 5/16 JIC	85-113	115-153
1.618	41.1	1 5/8 JIC	115-133	156-180
1.870	47.5	1 7/8 JIC	125-167	169-226
2.492	63.3	2 1/2 JIC	190-258	258-350

JIC flare fittings seal with metal to metal contact between the flared nose of the fitting and the flared tube face in the female connection.

The minimum torque values listed are to provide a benchmark that give optimum results for leak free connections. Actual torque values should be based on individual application.

NOTE: Do not apply thread sealant (teflon tape) on the JIC threads.

Leaks can result from vibration, thermal cycling and from loads being supported by the connection (i.e. using the fitting in the connection to support mechanical loads).

IMPORTANT: Use the lowest torque value from the chart when wet torquing.

RECOMMENDED ASSEMBLY

STEP 1: Inspect for possible contamination or damage from shipping or handling. Sealing surface should be smooth.

STEP 2: Lubricate the threads and the entire surface of the cone with hydraulic fluid or a light lubricant.

STEP 3: Align mating components for hand connection and turn flare nut until sealing surfaces make full contact.

STEP 4: Torque nut to the values shown in the above table.

STEP 5: When torquing nut onto a straight flared fitting, it may be necessary to also place a wrench on the flared fitting wrench pad to prevent it from turning during assembly.

ALTERNATE ASSEMBLY METHOD

STEP 1: Inspect for possible contamination or damage from shipping or handling. Sealing surface should be smooth.

STEP 2: Lubricate the threads and the entire surface of the cone with hydraulic fluid or a light lubricant.

STEP 3: Align mating components for hand connection and turn flare nut until sealing surfaces make full contact.

STEP 4: Lightly wrench tighten the nut until there is resistance.

STEP 5: Place a wrench on wrench pad next to nut as near the 6 o'clock position as possible.

STEP 6: Place second wrench on nut as near the 3 o'clock position as possible.

STEP 7: Turn nut clockwise to no less than the 4 o'clock position, but no more than the 6 o'clock position. Required rotation generally decreases as size increases.

ORB (O-RING BOSS) THREAD IDENTIFICATION & TORQUE

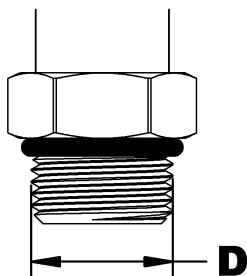

D		Identification of adapter	TORQUE	
in	mm		lbs-ft	N-m
-		3/8 ORB	8-9	12-13
0.433	11	7/16 ORB	13-15	18-20
0.496	12.6	1/2 ORB	14-15	19-21
0.559	14.2	9/16 ORB	23-24	32-33
0.740	18.8	3/4 ORB	40-43	55-57
0.870	22.1	7/8 ORB	43-48	59-64
1.055	26.8	1 1/16 ORB	68-75	93-101
1.185	30.1	1 3/16 ORB	83-90	113-122
1.307	33.2	1 5/16 ORB	112-123	152-166
1.618	41.1	1 5/8 ORB	146-161	198-218
1.870	47.5	1 7/8 ORB	154-170	209-230
2.492	63.3	2 1/2 ORB	218-240	296-325

SAE O-rings (O-Ring Boss) are straight thread fittings that seal using an O-ring between the thread and the wrench flats of the fitting. The O-ring seals against the machined seat on the female port.

O-ring fittings can be either adjustable or non-adjustable. Nonadjustable fittings are screwed into a port where no alignment is needed. Adjustable fittings can be oriented in a specific direction.

Fittings with O-rings offer advantages over metal-to-metal fittings. Under or over-tightening any fitting can allow leakage, but all-metal fittings are more susceptible to leakage because they must be tightened to a higher and narrower torque range. This makes it easier to strip threads or crack or distort fitting components, which prevents proper sealing.

NOTE: Do not apply thread sealant (teflon tape) on the ORB threads.

Leaks can also result from vibration, thermal cycling and from loads being supported by the connection (i.e. using the fitting in the connection to support mechanical loads).

IMPORTANT: Use the lowest torque value from the chart when wet torquing.

RECOMMENDED ASSEMBLY ORB (O-RING) NON-ADJUSTABLE

STEP 1: Inspect all components for damage or contamination.

STEP 2: Lubricate O-ring and threads on fitting with your hydraulic system fluid.

STEP 3: Turn fitting into port until finger tight, then torque to the value shown in the following table.

NOTE: Use the lowest torque value from the chart when wet torquing.

RECOMMENDED ASSEMBLY ORB (O-RING) ADJUSTABLE

STEP 1: Inspect all components for damage or contamination.

STEP 2: Lubricate O-ring and threads on fitting with your hydraulic system fluid.

STEP 3: Looking at fitting from the male ORB end, turn manually the nut as far as possible from the O-ring.

STEP 4: Using wrench, turn fitting into port until the washer touches thread nearest wrench pad.

STEP 5: Back off fitting counterclockwise not exceeding one revolution until it is oriented in the correct position.

STEP 6: Place wrench on the wrench pad of fitting to prevent fitting from turning, and torque nut to the value shown in the above table.

Manufactured by:



RAD TECHNOLOGIES INC.

Division Thetford Mines

2835, Chemin de l'Aéroport

Thetford Mines, Québec, Canada, G6G 5R7

Tel.: (418) 338-4499 - Fax.: (418) 338-6090

E-mail : radtech@radinter.com

Internet : www.radinter.com

Printed in Canada