

# **BER-VAC**

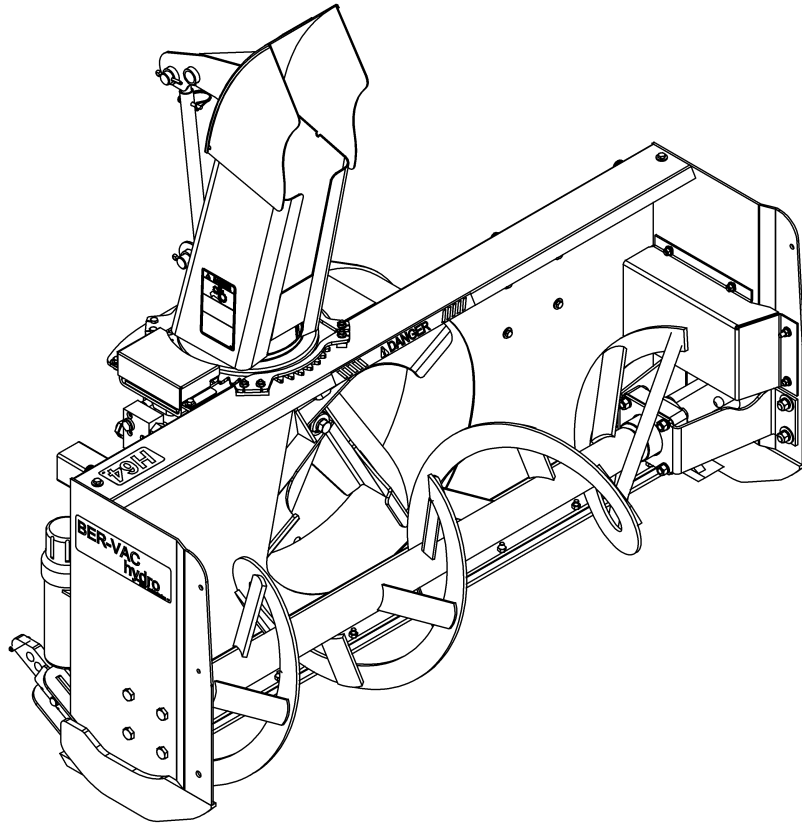

## ***PARTS MANUAL***

**64" HYDRAULIC SNOWBLOWER – H64A**

**76" HYDRAULIC SNOWBLOWER – H76A**

**84" HYDRAULIC SNOWBLOWER – H84A**

SERIAL NO. 2100000 AND UP

PM 0303SB-A  
02/10





---

# TABLE OF CONTENT

---

INTRODUCTION .....	2
PARTS .....	3
Decals .....	3
Hydraulic Block .....	5
Hydraulic Snowblower H64A .....	6
Hydraulic Snowblower H76A & H84A .....	8
Hydraulic System H64A .....	10
Hydraulic System H76A & H84A .....	11
Chute – for H64A .....	12
Chute – for H76A & H84A.....	13
Hydraulic Rotation.....	14
Hydraulic Valve For Chute Rotation - 8183A.....	15
Hydraulic Valve For Hydraulic Deflector - 8184A.....	16
Universal Hitch – 8153.....	18
Drift Cutters – 8152.....	19
Electric Deflector - 8154 .....	20
Switch Box kit - 669285 .....	21
Hydraulic Motors .....	22
WARRANTY .....	24
TORQUE SPECIFICATION TABLE.....	25

---

# PARTS

---

## INTRODUCTION

All parts are illustrated in "exploded views" which show the individual parts in their normal relationship to each other. Reference numbers are used in the illustrations. These numbers correspond to those in the "Reference Number" (REF) column, and are followed by the description and quantity required.

O/L - "Obtain Locally" in the part number column indicates common hardware that is available at your local hardware supply.

Right hand and left hand are determined by those seen by the conductor standing behind the equipment.

Orders must give the complete description, correct part number, the total amount required, the serial number, the method of shipment and the shipping address.

The manufacturer reserves the rights to change, modify, or eliminate from time to time, for technical or other reasons, certain or all data, specifications, or the product or products themselves, without any liability or obligation.

The parts listed here are available through your local dealer.

---

## MANUAL HOLDER – ALL MODELS

REF.	DESCRIPTION	QTÉ	# PIÈCE
1	Manual holder	1	4200036
2	Bolt hex. 5/16" NC x 3/4" lg gr. 5, PTD	2	O/L
3	Nut nylon insert 5/16" NC, PTD	2	O/L

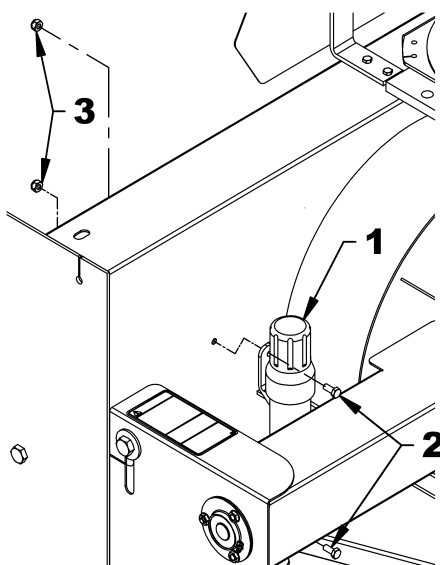

# PARTS

**Replace immediately if damaged**  
**For H64A snowblower**

**⚠ DANGER**

TO AVOID SERIOUS INJURY:  
 KEEP HANDS OUT OF THIS  
 DISCHARGE CHUTE WHILE  
 ENGINE IS RUNNING

POUR ÉVITER DES  
 BLESSURES GRAVES:  
 GARDER LES MAINS ÉLOIGNÉES  
 DE CETTE GOULOTTE LORSQUE  
 LE MOTEUR EST EN MARCHÉ 86

656779

**⚠ WARNING**

FAILURE TO FOLLOW SAFE OPERATING PROCEDURES MAY RESULT IN INJURY.

- FOR SAFE OPERATION FOLLOW ALL OPERATING INSTRUCTIONS AND SAFETY PRECAUTIONS IN OPERATOR'S MANUAL.
- EYE PROTECTION MUST BE WORN AT ALL TIMES.
- KEEP HANDS, FEET AND CLOTHING AWAY FROM POWER DRIVEN PARTS.
- STOP ENGINE BEFORE LEAVING OPERATOR POSITION.
- WAIT FOR ALL MOVEMENTS TO STOP BEFORE STARTING TO ADJUST, LUBRICATE, CLEAN OR UNCLG THE MACHINE.
- KEEP THE AREA OF OPERATION CLEAR OF ALL PERSONS AND ANIMALS.
- KEEP ALL GUARDS AND SHIELDS IN PLACE.
- NEVER DIRECT DISCHARGE TOWARD BYSTANDERS, BUILDINGS, CARS ETC.
- ALWAYS USE A DUST MASK WHEN WORKING IN DUSTY CONDITIONS.
- KEEP PLASTIC MATERIALS AWAY FROM INTENSE HEAT AND OPEN FLAME.
- NEVER ALLOW PASSENGERS ON THE ATTACHMENT.

228

**⚠ MISE EN GARDE**

NÉGLIGER DE SUIVRE LES PROCÉDURES SECURITAIRES D'UTILISATION PEUT ENTRAÎNER DES BLESSURES.

- POUR UNE UTILISATION SECURITAIRE, SUIVRE TOUTES LES INSTRUCTIONS D'UTILISATION ET PRECAUTIONS SECURITAIRES DANS LE MANUEL DE L'OPERATEUR.
- PORTER DES LUNETTES DE SECURITE EN TOUT TEMPS.
- GARDER MAINS, PIEDS ET VÊTEMENTS ÉLOIGNÉS DES PIÉCES MOTRICES.
- ARRÊTER LE MOTEUR AVANT DE QUITTER LA POSITION DE L'OPERATEUR.
- ATTENDRE QUE TOUTS LES MOUVEMENTS SOIENT ARRÊTÉS AVANT D'AJUSTER, LUBRIFIER, NETTOYER OU DÉBLOQUER LA MACHINE.
- GARDER L'ENDROIT D'UTILISATION DÉGAGÉ DE TOUTES PERSONNES ET ANIMAUX.
- GARDER TOUTS LES ÉCRANS PROTECTEURS EN PLACE.
- JAMAIS DIRIGER L'ÉVACUATION VERS DES PIÉTONS, BÂTIMENTS, AUTOMOBILES, ETC.
- TOUJOURS UTILISER UN MASQUE À POUSSIÈRE DANS UN ENVIRONNEMENT POUSSIÉREUX.
- GARDER TOUTES LES MATIÈRES PLASTIQUES ÉLOIGNÉES DE LA CHALEUR INTENSE ET DES FLAMMES.
- NE JAMAIS PERMETTRE DE PASSAGERS SUR CETTE MACHINE.

228

**⚠ DANGER**

AVOID INJURY FROM  
 ROTATING AUGER  
 KEEP HANDS, FEET AND  
 CLOTHING AWAY

POUR ÉVITER DES  
 BLESSURES GRAVES:  
 GARDER LES MAINS, LES PIEDS  
 ET LES VÊTEMENTS ÉLOIGNÉS  
 DES VIS SANS FIN 87

656780

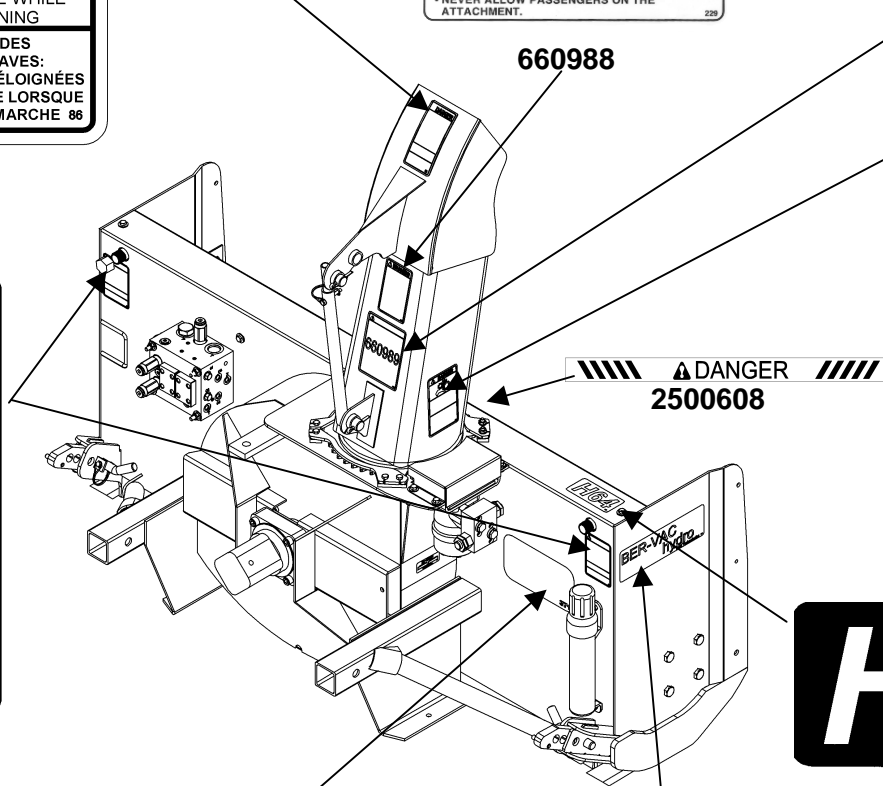

**⚠ DANGER**

AVOID INJURY FROM ROTATING GEARS:

- KEEP HANDS AND CLOTHING AWAY
- STOP ENGINE AND REMOVE IGNITION KEY BEFORE COMING NEAR ROTATING GEARS
- DO NOT ATTEMPT TO INSTALL OR REMOVE ROTATING GEARS WITHOUT READING OPERATOR'S MANUAL

ÉVITEZ LES BLESSURES PAR LES ENGRENAGES:

- GARDER MAINS ET VÊTEMENTS ÉLOIGNÉS
- ARRÊTEZ LE MOTEUR ET ENLEVEZ LA CLÉ DE CONTACT AVANT DE VOUS APPROCHER DES ENGRENAGES
- NE TENTEZ PAS D'INSTALLER OU D'ENLEVER LES ENGRENAGES SANS LIRE LE MANUEL D'OPERATEUR 88

2500330



2500311



2500308

**⚠ WARNING - ATTENTION**

- TO AVOID SERIOUS PERSONAL INJURY, ESCAPING HYDRAULIC FLUID UNDER PRESSURE CAN PENETRATE THE SKIN CAUSING SERIOUS INJURY.
- DO NOT USE YOUR HANDS TO CHECK FOR LEAKS. USE A PIECE OF CARDBOARD OR PAPER TO SEARCH FOR LEAKS.
- STOP ENGINE AND RELIEVE PRESSURE BEFORE CONNECTING OR DISCONNECTING LINES.
- TIGHTEN ALL CONNECTIONS BEFORE STARTING ENGINE OR PRESSURIZING LINES.
- IF ANY FLUID IS INJECTED INTO THE SKIN, OBTAIN MEDICAL ATTENTION IMMEDIATELY OR GANGRENE MAY RESULT.

- UN LIQUIDE HYDRAULIQUE / DIESEL QUI S'ÉCHAPPE SOUS PRESSION PEUT PÉNÉTRER LA PEAU ET CAUSER DES BLESSURES SÉRIEUSES.
- NE PAS UTILISER LES MAINS POUR CHERCHER UNE FUITE. UTILISER UN MORCEAU DE PAPIER OU DE CARTON.
- ARRÊTER LE MOTEUR ET ÉVACUER LA PRESSION AVANT DE CONNECTER OU DE DÉCONNECTER LES LIGNES.
- SERRER TOUTES LES CONNEXIONS AVANT DE DEMARRER LE MOTEUR OU DE REMETTRE LA PRESSION SUR LES LIGNES.
- SI UN LIQUIDE EST INJECTÉ DANS LA PEAU, OBTENIR IMMÉDIATEMENT UNE ATTENTION MÉDICALE. UNE GANGRENE PEUT RÉSULTER.

89

2500315

# PARTS

## Replace immediately if damaged For H76A & H84 snowblowers

**MISE EN GARDE**

NÉGLIGER DE SUIVRE LES PROCÉDURES SÉCURITAIRES D'UTILISATION PEUT ENTRAÎNER DES BLESSURES.

- POUR UNE UTILISATION SÉCURITAIRE, SUIVRE TOUTES LES INSTRUCTIONS D'UTILISATION ET PRÉCAUTIONS SÉCURITAIRES DANS LE MANUEL DE L'OPÉRATEUR.
- PORTER DES LUNETTES DE SÉCURITÉ EN TOUT TEMPS.
- GARDER MAINS, PIEDS ET VÊTEMENTS ÉLOIGNÉS DES PIÈCES MOTRICES.
- ARRÊTER LE MOTEUR AVANT DE QUITTER LA POSITION DE L'OPÉRATEUR.
- ATTENDRE QUE TOUTS LES MOUVEMENTS SOIENT ARRÊTÉS AVANT D'AJUSTER, LUBRIFIER, NETTOYER OU DÉBOUQUER LA MACHINE.
- GARDER L'ENDROIT D'UTILISATION DÉGAGÉ DE TOUTES PERSONNES ET ANIMAUX.
- GARDER TOUS LES ÉCRANS PROTECTEURS EN PLACE.
- JAMAIS DIRIGER L'ÉVACUATION VERS DES PIÉTONS, BÂTIMENTS, AUTOMOBILES, ETC.
- TOUTOURS UTILISER UN MASQUE À POUSSIÈRE DANS UN ENVIRONNEMENT POUSSIÉREUX.
- GARDER TOUTES LES MATIÈRES PLASTIQUES ÉLOIGNÉES DE LA CHALEUR INTENSE ET DES FLAMMES.
- NE JAMAIS PERMETTRE DE PASSAGERS SUR CETTE MACHINE.

**WARNING**

FAILURE TO FOLLOW SAFE OPERATING PROCEDURES MAY RESULT IN INJURY.

- FOR SAFE OPERATION FOLLOW ALL OPERATING INSTRUCTIONS AND SAFETY PRECAUTIONS IN OPERATOR'S MANUAL.
- EYE PROTECTION MUST BE WORN AT ALL TIMES.
- KEEP HANDS, FEET AND CLOTHING AWAY FROM POWER DRIVEN PARTS.
- STOP ENGINE BEFORE LEAVING OPERATOR POSITION.
- WAIT FOR ALL MOVEMENTS TO STOP BEFORE STARTING TO ADJUST, LUBRICATE, CLEAN OR UNLOAD THE MACHINE.
- KEEP THE AREA OF OPERATION CLEAR OF ALL PERSONS AND ANIMALS.
- KEEP ALL GUARDS AND SHIELDS IN PLACE.
- NEVER DIRECT DISCHARGE TOWARD BYSTANDERS, BUILDINGS, CARS ETC.
- ALWAYS USE A DUST MASK WHEN WORKING IN DUSTY CONDITIONS.
- KEEP PLASTIC MATERIALS AWAY FROM INTENSE HEAT AND OPEN FLAME.
- NEVER ALLOW PASSENGERS ON THE ATTACHMENT.

**DANGER**

TO AVOID SERIOUS INJURY: KEEP HANDS OUT OF THIS DISCHARGE CHUTE WHILE ENGINE IS RUNNING

POUR ÉVITER DES BLESSURES GRAVES: GARDER LES MAINS ÉLOIGNÉES DE CETTE GOULOTTE LORSQUE LE MOTEUR EST EN MARCHÉ

**DANGER**

AVOID INJURY FROM ROTATING GEARS: KEEP HANDS AND CLOTHING AWAY

- STOP ENGINE AND REMOVE IGNITION KEY BEFORE COMING NEAR ROTATING GEARS
- DO NOT ATTEMPT TO INSTALL OR REMOVE ROTATING GEARS WITHOUT READING OPERATOR'S MANUAL.

ÉVITEZ LES BLESSURES PAR LES ENGRENAGES:

- GARDEZ MAINS ET VÊTEMENTS ÉLOIGNÉS
- ARRÊTEZ LE MOTEUR ET ENLEVEZ LA CLÉ DE CONTACT AVANT DE VOUS APPROCHER DES ENGRENAGES
- NE TENTEZ PAS D'INSTALLER OU D'ENLEVER LES ENGRENAGES SANS LIRE LE MANUEL D'OPÉRATEUR

660989

660988

656779

2500330

**DANGER**

AVOID INJURY FROM ROTATING AUGER KEEP HANDS, FEET AND CLOTHING AWAY

POUR ÉVITER DES BLESSURES GRAVES: GARDER LES MAINS, LES PIEDS ET LES VÊTEMENTS ÉLOIGNÉS DES VIS SANS FIN

656780

**DANGER**

2500608

**H76**

2500312

**H84**

2500632

**WARNING - ATTENTION**

- TO AVOID SERIOUS PERSONAL INJURY: ESCAPING HYDRAULIC FLUID UNDER PRESSURE CAN PENETRATE THE SKIN CAUSING SERIOUS INJURY.
- DO NOT USE YOUR HANDS TO CHECK FOR LEAKS. USE A PIECE OF CARDBOARD OR PAPER TO SEARCH FOR LEAKS.
- STOP ENGINE AND RELIEVE PRESSURE BEFORE CONNECTING OR DISCONNECTING LINES.
- TIGHTEN ALL CONNECTIONS BEFORE STARTING ENGINE OR PRESSURIZING LINES.
- IF ANY FLUID IS INJECTED INTO THE SKIN, OBTAIN MEDICAL ATTENTION IMMEDIATELY OR GANGRENE MAY RESULT.

- UN LIQUIDE HYDRAULIQUE / DIESEL QUI S'ÉCHAPPE SOUS PRESSION PEUT PÉNÉTRER LA PEAU ET CAUSER DES BLESSURES SÉRIEUSES.
- NE PAS UTILISER LES MAINS POUR CHERCHER UNE FUITE. UTILISER UN MORCEAU DE PAPIER OU DE CARTON.
- ARRÊTER LE MOTEUR ET ÉVACUER LA PRESSION AVANT DE CONNECTER OU DE DÉCONNECTER LES LIGNES.
- SERRER TOUTES LES CONNEXIONS AVANT DE DÉMARRER LE MOTEUR OU DE REMETTRE LA PRESSION SUR LES LIGNES.
- SI UN LIQUIDE EST INJECTÉ DANS LA PEAU, OBTENIR IMMÉDIATEMENT UNE ATTENTION MÉDICALE. UNE GANGRÈNE PEUT RÉSULTER.

2500315



2500308

# PARTS

## HYDRAULIC BLOCK ASSEMBLY – 3920030

REF.	DESCRIPTION	QTY	PART #
1	Hydraulic block	1	3920027
2	Cover	2	3920028
3	O-ring 0.07" x 3/8" x 1/2" ext	8	3900462
4	Pressure restrictor preset @ 2000 PSI	1	3900457
5	Pressure restrictor preset @ 3000 PSI	1	3900458
	Seal kit for 3900457 et 3900458	2	3900459
6	4 way sequential valve preset @ 1700 PSI	1	3900460
	Seal kit for 3900460	1	3900461
7	Hydraulic male cap 7/16" ORB	1	2600213
8	Hydraulic male cap 9/16" ORB	6	2600212
9	Flow restrictor 0.0781" hole	2	669269
10	Flow restrictor 0.0935" hole	1	665942
11	Bolt hex. 5/16 NC x 5" gr.5, PTD	4	0100033
12	Allen socket head cap screw 10-24 NC x 7/8" gr.5 black, cylindr.	8	0800047
13	Nylon insert locknut 5/16 NC, PTD	4	1000005
14	Flat washer 5/16" (3/8" int), PTD	8	1400003

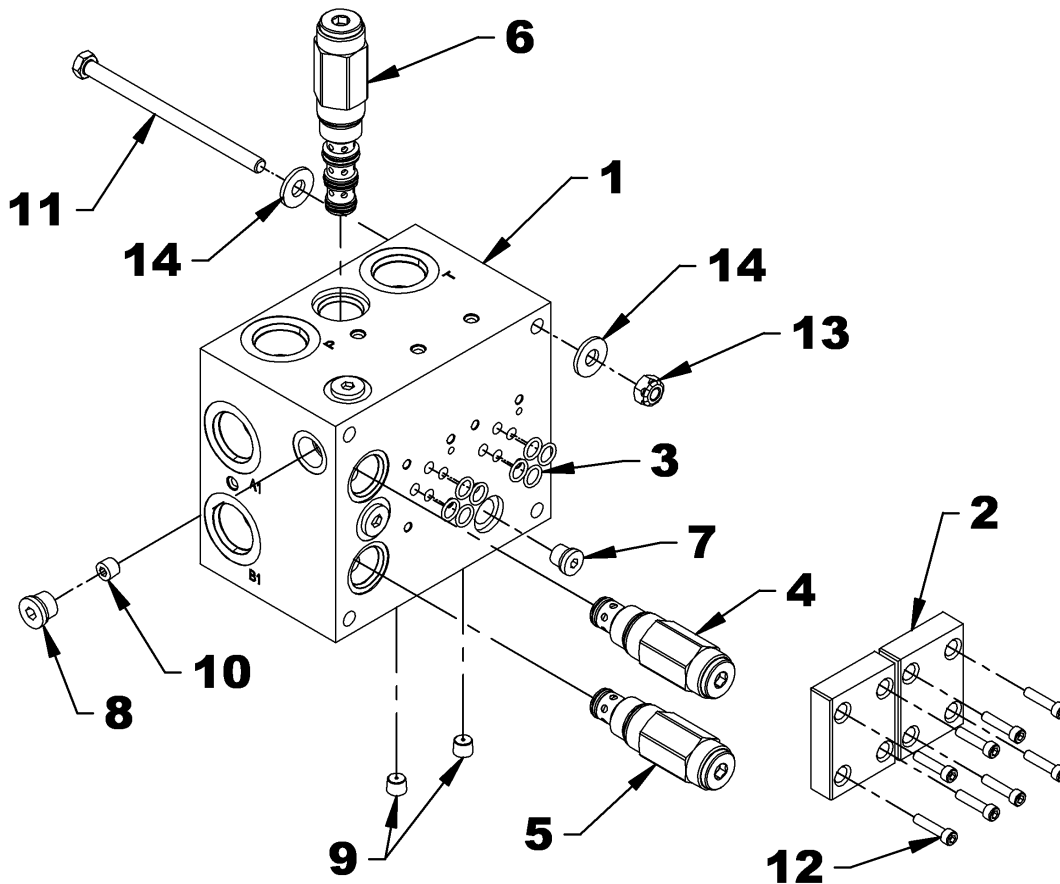

---

# PARTS

---

## HYDRAULIC SNOWBLOWER H64A

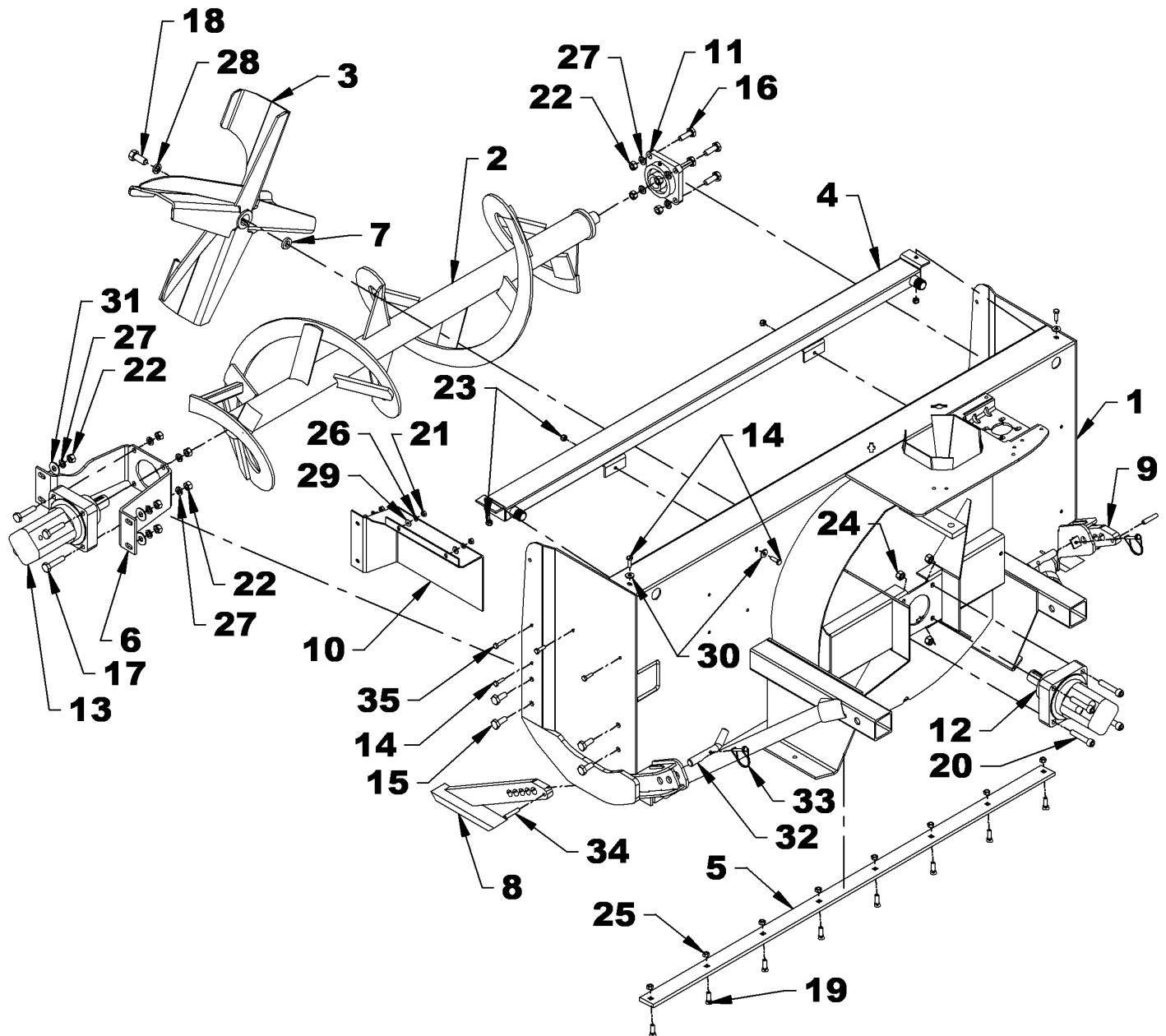

---

# PARTS

---

## HYDRAULIC SNOWBLOWER H64A

REF.	DESCRIPTION	QTY	PART #
1	Housing	1	-----
2	Auger	1	669292
3	Fan	1	669290
4	Oil cooler	1	669291
5	Cutting edge	1	669305
6	Motor support	1	669139
7	Spacer	1	665858
8	Right skid shoe	1	669020
9	Left skid shoe	1	669021
10	Hose guard	1	669145
11	Flange bearing 1 1/4", 4 holes	1	4300001
12	Hydraulic motor 89cc without valve	1	3910058
13	Hydraulic motor 293cc without valve	1	3910059
14	Bolt hex. 5/16" NC x 1" gr.5, PTD	7	0100019
15	Bolt hex. 1/2" NC x 1 1/4" gr.5, PTD	4	0100069
16	Bolt hex. 1/2" NC x 1 1/2" gr.5, PTD	4	0100070
17	Bolt hex. 1/2" NC x 2 1/4" gr.5, PTD	4	0100075
18	Bolt hex. 5/8" NF x 1 1/2" gr.5, PTD	1	0100240
19	Plow bolt 3/8" NC x 1 1/4" Gr.5 PTD	8	0400002
20	Allen socket head cap screw 1/2 NC x 2 1/2" Gr.5 black, cylind.	4	0800021
21	Nut hex. 5/16" NC	4	0900002
22	Nut hex. 1/2" NC	12	0900006
23	Nylon insert locknut 5/16-18NC PTD	4	1000005
24	Nylon insert locknut 1/2"-13NC PTD	4	1000011
25	Stover locknut 3/8" NC PTD	8	1100003
26	Lockwasher 5/16" PTD	4	1200003
27	Lockwasher 1/2" PTD	12	1200006
28	Lockwasher 5/8" PTD	1	1200007
29	Flat washer 1/4" (5/16" int) PTD	4	1400002
30	Flat washer 5/16" (3/8" int) PTD	4	1400003
31	Flat washer 1/2" (9/16" int) PTD	4	1400006
32	Pin for skid shoe	2	667899
33	Round wire lock pin 1/4" X 1 3/4"	2	1900006
34	Spring pin dia. 3/8" X 2" lg	2	1600024
35	Bolt hex. 5/16" NC x 1 1/4" gr.5, PTD	1	0100020

---

# PARTS

---

## HYDRAULIC SNOWBLOWER H64A, H76A & H84A

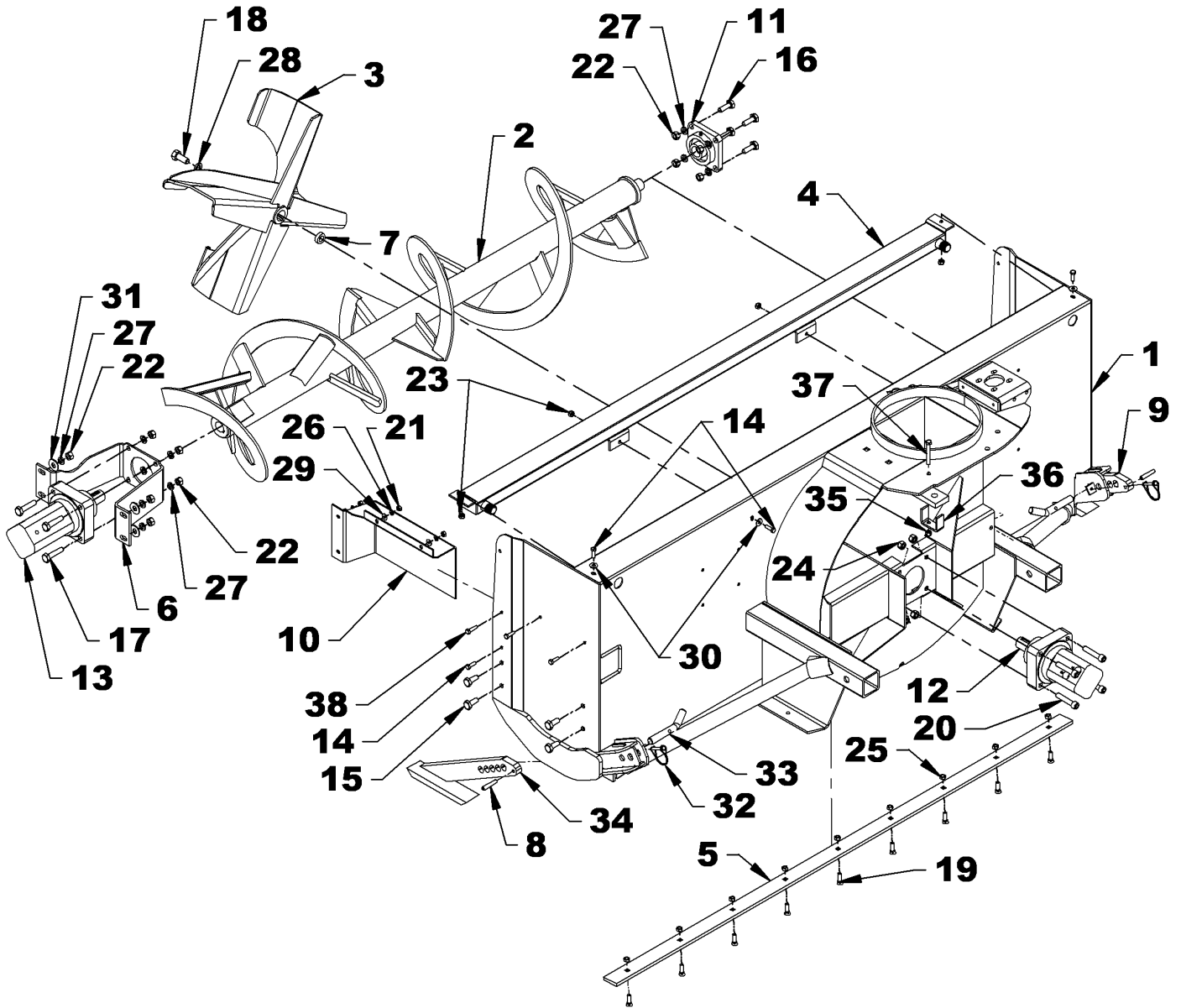

# PARTS

## HYDRAULIC SNOWBLOWER H64A, H76A & H84A

REF.	DESCRIPTION	QTY	PART #
1	Housing <b>H76A</b>	1	-----
	Housing <b>H84A</b>	1	-----
2	Auger <b>H76A</b>	1	669141
	Auger <b>H84A</b>	1	669304
3	Fan	1	669138
4	Oil cooler	1	669137
5	Cutting edge <b>H76A</b>	1	669306
	Cutting edge <b>H84A</b>	1	669307
6	Motor support	1	669139
7	Spacer	1	669140
8	Right skid shoe	1	669020
9	Left skid shoe	1	669021
10	Hose guard	1	669145
11	Flange bearing 1 1/4", 4 holes	1	4300001
12	Hydraulic motor 127cc without valve	1	3910021
13	Hydraulic motor 409cc without valve	1	3910022
14	Bolt hex. 5/16" NC x 1" gr.5, PTD	7	0100019
15	Bolt hex. 1/2" NC x 1 1/4" gr.5, PTD	4	0100069
16	Bolt hex. 1/2" NC x 1 1/2" gr.5, PTD	4	0100070
17	Bolt hex. 1/2" NC x 2 1/4" gr.5, PTD	4	0100075
18	Bolt hex. 5/8" NF x 1 1/2" gr.5, PTD	1	0100240
19	Plow bolt 3/8" NC x 1 1/4" Gr.5 PTD for <b>H76A</b>	9	0400002
	Plow bolt 3/8" NC x 1 1/4" Gr.5 PTD for <b>H84A</b>	10	0400002
20	Allen socket head cap screw 1/2 NC x 2 1/2" Gr.5 black, cylind.	4	0800021
21	Nut hex. 5/16" NC	4	0900002
22	Nut hex. 1/2" NC	12	0900006
23	Nylon insert locknut 5/16-18NC PTD	4	1000005
24	Nylon insert locknut 1/2"-13NC PTD	4	1000011
25	Stover locknut 3/8" NC PTD for <b>H76A</b>	9	1100003
	Stover locknut 3/8" NC PTD for <b>H84A</b>	10	1100003
26	Lockwasher 5/16" PTD	4	1200003
27	Lockwasher 1/2" PTD	12	1200006
28	Lockwasher 5/8" PTD	1	1200007
29	Flat washer 1/4" (5/16" int) PTD	4	1400002
30	Flat washer 5/16" (3/8" int) PTD	4	1400003
31	Flat washer 1/2" (9/16" int) PTD	4	1400006
32	Pin for skid shoe	2	667899
33	Round wire lock pin 1/4" X 1 3/4"	2	1900006
34	Spring pin dia. 3/8" X 2" lg	2	1600024
35	Nylon insert locknut 3/8" NC	2	1000006
36	Hose support	1	669144
37	Bolt hex. 3/8" NC x 2 3/4" gr.5, PTD	1	0100045
38	Bolt hex. 5/16" NC x 1 1/4" gr.5, PTD	1	0100020

# PARTS

## HYDRAULIC SYSTEM H64A

REF.	DESCRIPTION	QTY	PART #
1	Hydraulic block 2 covers included	1	3920030
2	Hose 3/4" x 25" lg	2	3700173
3	Hose 3/4" x 33" lg	2	3700159
4	Hose 3/4" x 59" lg	1	3700160
5	Hose 1/4" x 30 1/4" lg	2	3700164
6	Elbow 45° 1 1/16" ORB M X 1 1/16" JIC M	2	2600184
7	Plastic guard for hoses 10"	1	669154
8	Hydraulic plug 7/16 ORB	4	2600048
9	Hydraulic plug 1 1/16-20 ORB	1	2600049
10	Female Hydraulic plug 1 1/16"-12 JIC 37°	1	2600183
11	Fitting 7/8" ORB M x 1 1/16" JIC M	4	2600058
12	Elbow 90° 7/16 ORB M x 7/16 JIC M	3	2600065
13	Adapter 7/16" JIC M X 7/16" ORB M	1	2600123
14	Adapter 3/4" NPT F x 1 1/16" JIC M	2	2600203
15	Union 1 1/16" JIC M x 1 1/16" ORB M	3	660571

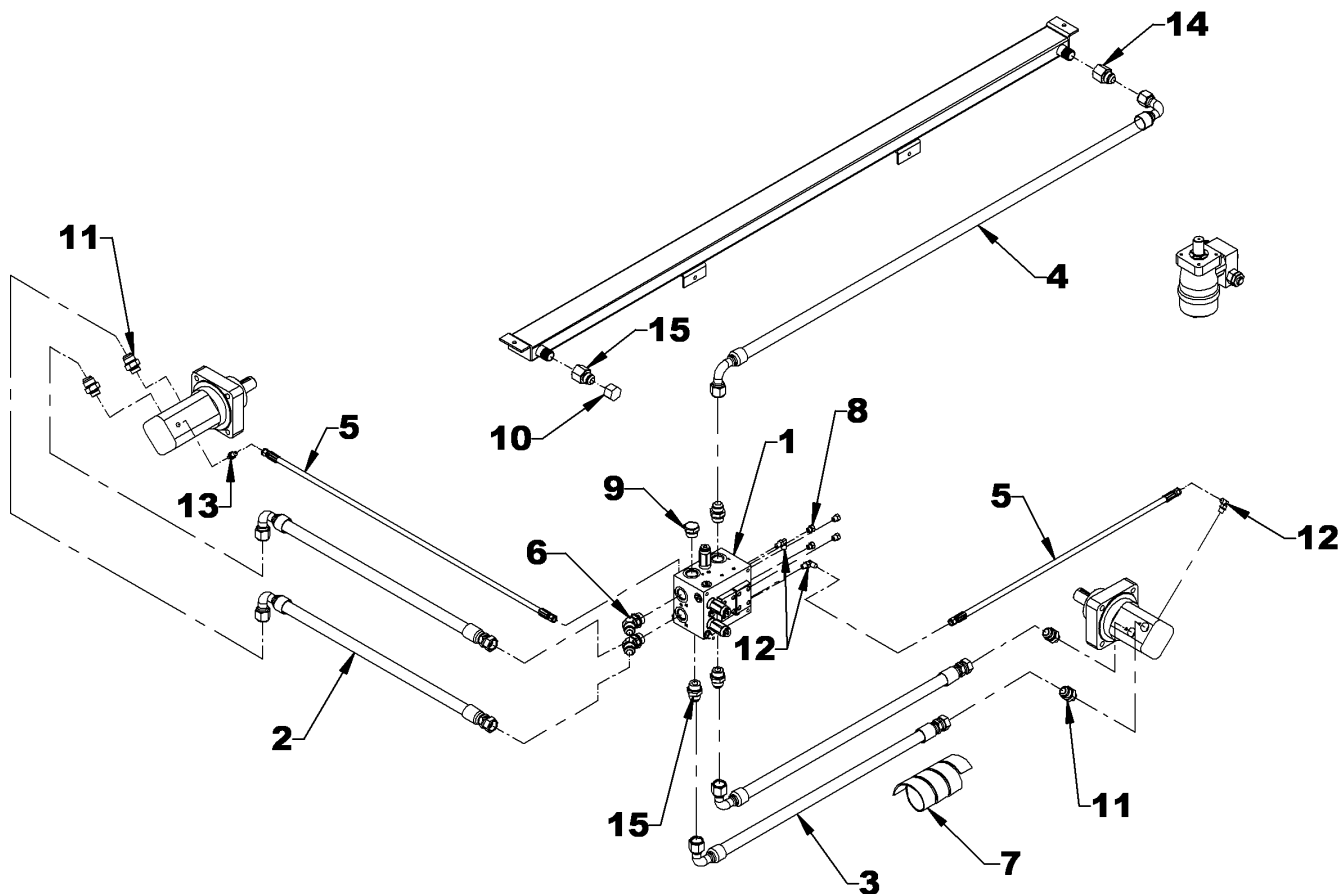

# PARTS

## HYDRAULIC SYSTEM H76A-H84A

REF.	DESCRIPTION	QTY	PART #
1	Hydraulic block 2 covers included	1	3920030
2	Hose 3/4" x 30 1/2" lg for <b>H76A</b>	2	3700158
	Hose 3/4" x 34 1/2" lg for <b>H84A</b>	2	3700174
3	Hose 3/4" x 33" lg	2	3700159
4	Hose 3/4" x 59" lg	1	3700160
5	Hose 1/4" x 38 1/2" lg for <b>H76A</b>	1	3700163
	Hose 1/4" x 42 1/2" lg for <b>H84A</b>	1	3700175
6	Hose 1/4" x 30 1/4" lg	1	3700164
7	Plastic guard for hoses 4"	1	669152
8	Plastic guard for hoses 10"	1	669154
9	Hydraulic plug 7/16 ORB	4	2600048
10	Hydraulic plug 1 1/16-20 ORB	1	2600049
11	Female Hydraulic plug 1 1/16"-12 JIC 37°	1	2600183
12	Fitting 7/8" ORB M x 1 1/16" JIC M	4	2600058
13	Elbow 90° 7/16 ORB M x 7/16 JIC M	3	2600065
14	Adapter 7/16" JIC M X 7/16" ORB M	1	2600123
15	Adapter 3/4" NPT F x 1 1/16" JIC M	2	2600203
16	Union 1 1/16" JIC M x 1 1/16 ORB M	5	660571

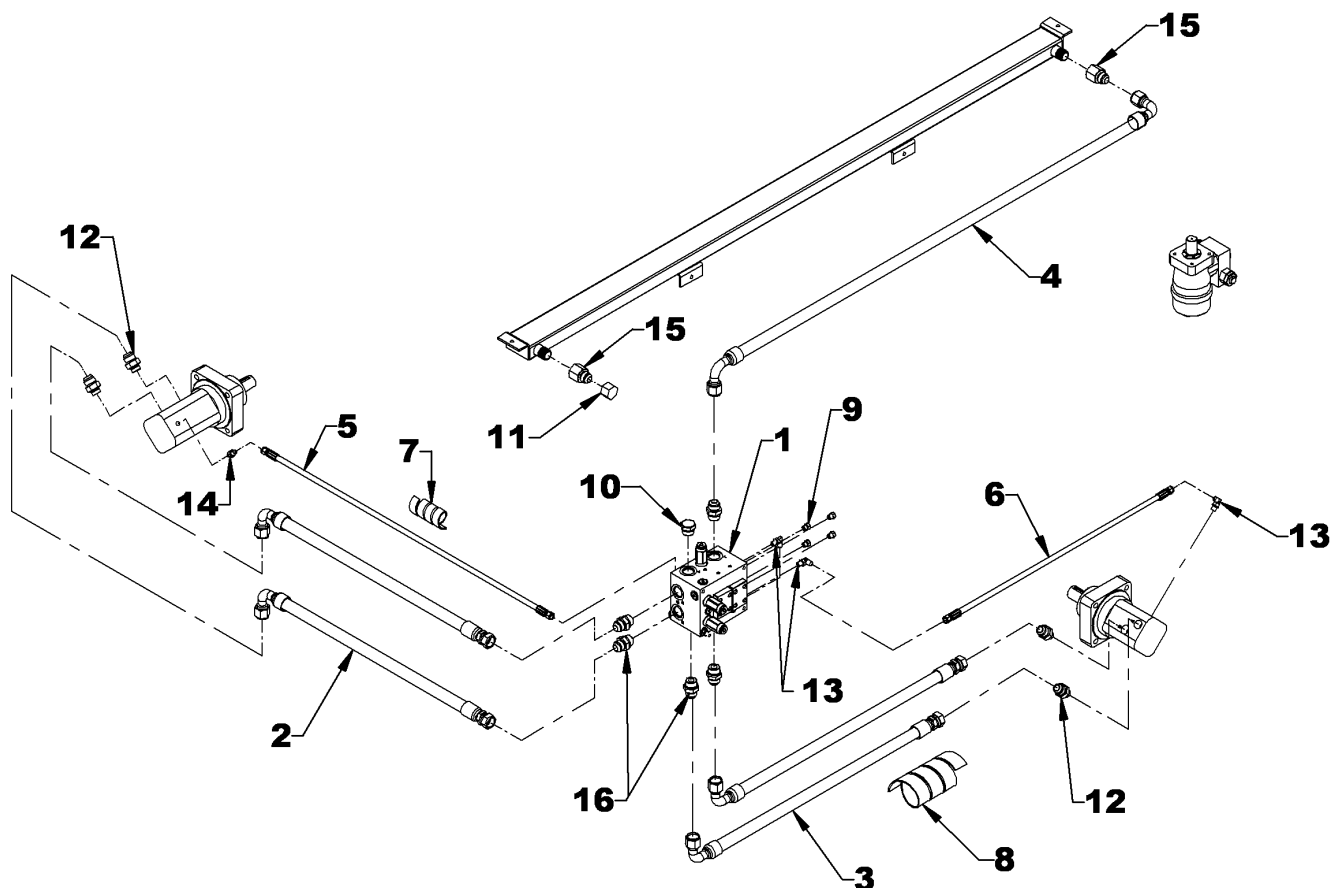

# PARTS

## CHUTE – FOR H64A

REF.	DESCRIPTION	QTY	PART #
1	Chute ass'y with decals	1	669293
2	Chute	1	669294
3	Adjustment rod	1	654074
4	Adjustment tube	1	654076
5	Retaining plate	2	665399
6	Retaining plate	1	666574
7	Spacer 3/8" thick x 3/4" larg. x 2 1/2" lg	4	665957
8	Spacer 16GA thick x 3/4" larg. x 2.5 lg	4	666191
9	Rotation bushing	1	659151
10	Bolt hex. 5/16"NC x 1 1/4" gr.5, PTD	4	0100020
11	Serrated flange nut 5/16" NC, PTD	8	0900036
12	Carriage bolt 5/16"NC x 1 1/4" gr.5, PTD	4	0300004
13	Cotter pin 1/4" x 2" lg PTD	2	1500022
14	Round wire lock pin 1/4", PTD	1	1900006

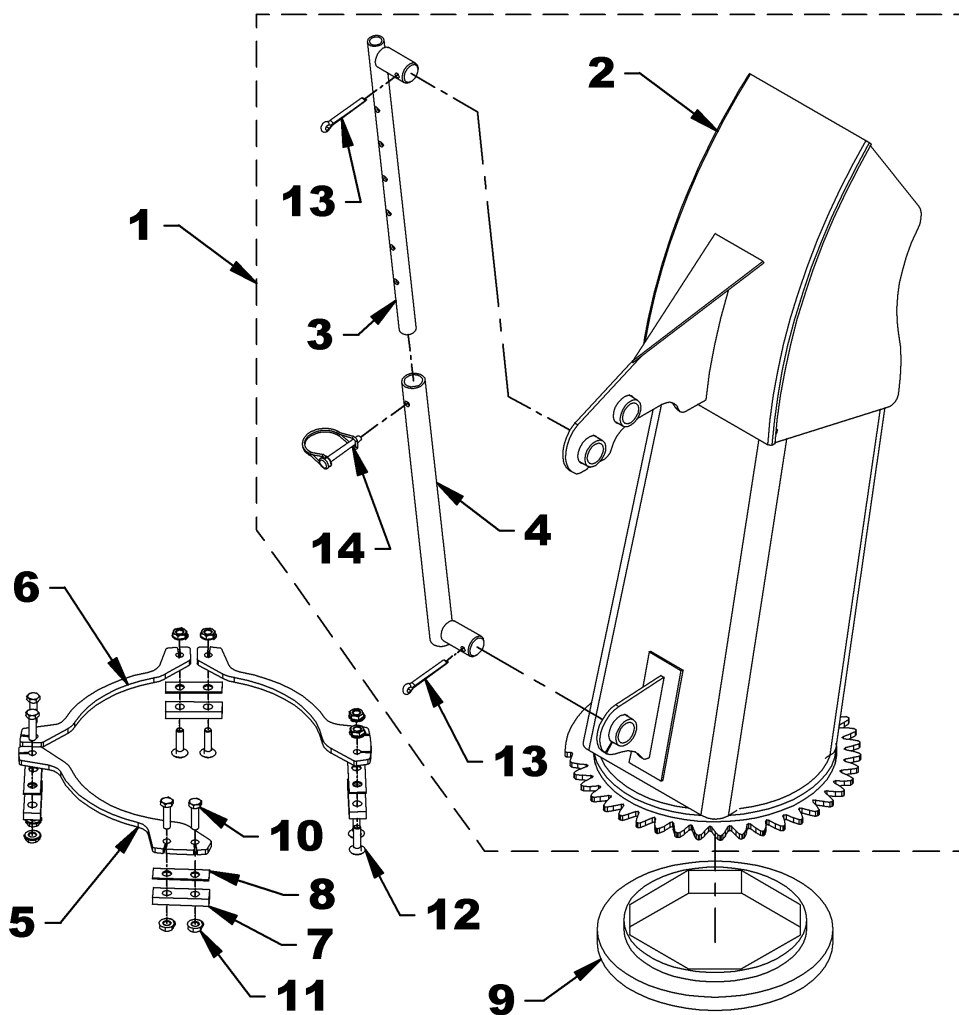

# PARTS

## CHUTE – FOR H76A & H84A

REF.	DESCRIPTION	QTY	PART #
1	Chute ass'y with decals	1	669300
2	Chute	1	669176
3	Adjustment rod	1	654074
4	Adjustment tube	1	654076
5	Retaining plate	2	665935
6	Spacer 3/8" thick x 1.25" larg. x 4 1/2" lg	3	669178
7	Spacer 3/16" thick x 1.25" larg. x 4 1/2" lg	3	669179
8	Rotation bushing	1	662834
9	Carriage bolt 1/2"NC x 1 3/4" gr.5, PTD	6	0300025
10	Serrated flange nut 1/2" NC, PTD	6	0900046
11	Cotter pin 1/4" x 2" lg PTD	1	1500022
12	Round wire lock pin 1/4", PTD		1900006

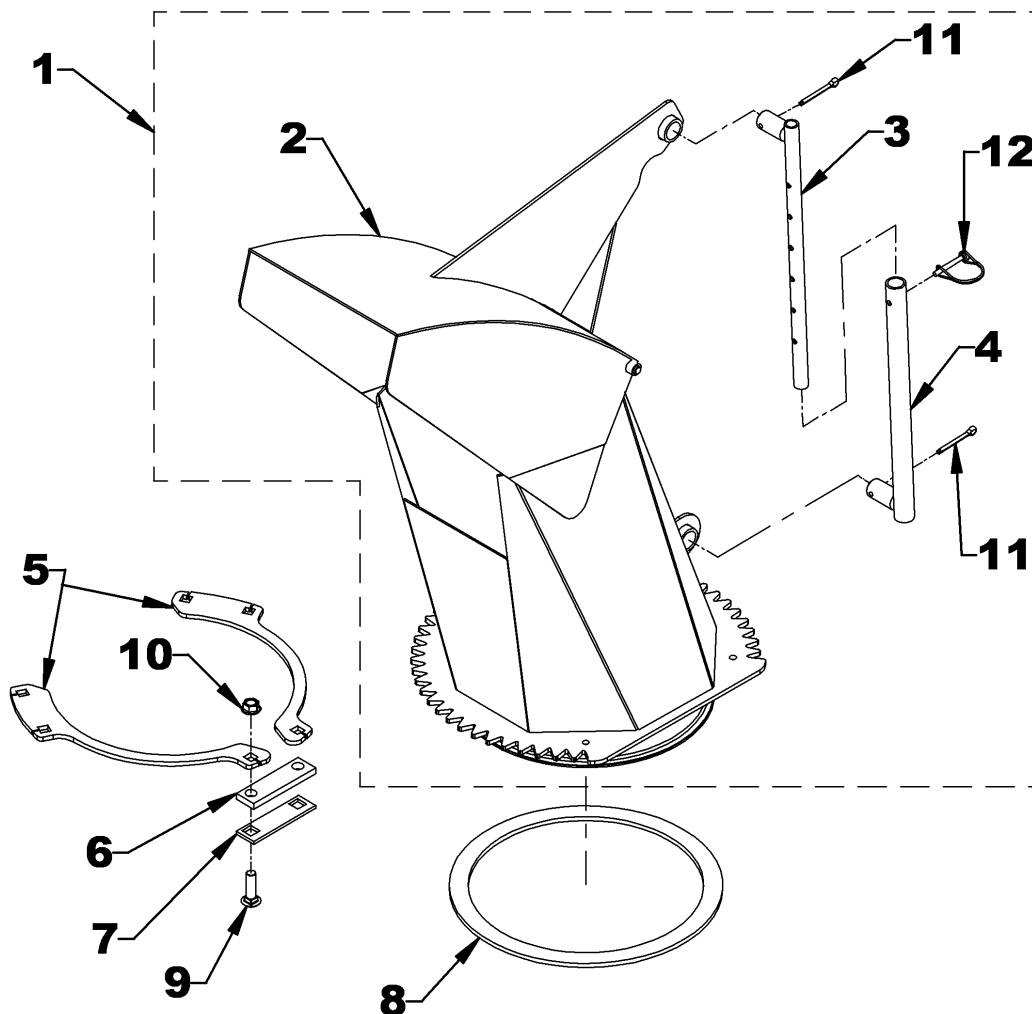

# PARTS

## HYDRAULIC ROTATION

REF.	DESCRIPTION	QTY	PART #
1	Hydraulic motor 160cc with preset valve @ 1600PSI	1	3910023
	Seal kit for 3910023	1	3910028
2	Relief valve adjust @1600 PSI	1	3920031
3	O-ring 0.103" x 15/16" x 1 1/8" OD	2	3900463
4	Motor gear	1	665930
5	Anchoring plate	1	667338
6A	Gear shield for <b>H64A</b>	1	669295
6B	Gear shield for <b>H76A &amp; H84A</b>	1	667929
7	Bolt hex. 1/4" NC x 1" gr.5, PTD	1	0100004
8	Bolt hex. 3/8" NC x 1 1/4" gr.5, PTD pour <b>H64A</b>	4	0100039
	Bolt hex. 3/8" NC x 1 1/2" gr.5, PTD pour <b>H76A &amp; H84A</b>	4	0100040
9	Bolt hex. 3/8" NC x 1 1/2" gr.5, PTD	2	0100040
10	Allen socket head cap screw 5/16" NC x 1 1/2" gr.5, cylindr.	4	0800011
11	Serrated flange bolt 5/16" NC x 3/4" Gr.5 PTD, <b>H64A</b>	3	0200083
	Serrated flange bolt 5/16" NC x 3/4" Gr.5 PTD, <b>H76A &amp; H84A</b>	4	0200083
12	Nut hex. 3/8" NC, PTD	2	0900003
13	Serrated flange nut 5/16" NC, PTD, <b>H64A</b>	3	0900036
	Serrated flange nut 5/16" NC, PTD, <b>H76A &amp; H84A</b>	4	0900036
14	Lockwasher 1/4", PTD	1	1200002
15	Lockwasher 3/8", PTD	4	1200004
16	Flat washer 1/4" (5/16" hole), PTD	1	1400002
17	Flat washer 3/8" (7/16" hole), PTD	4	1400004
18	Key 1/4" x 1/4" x 1" lg	1	655379

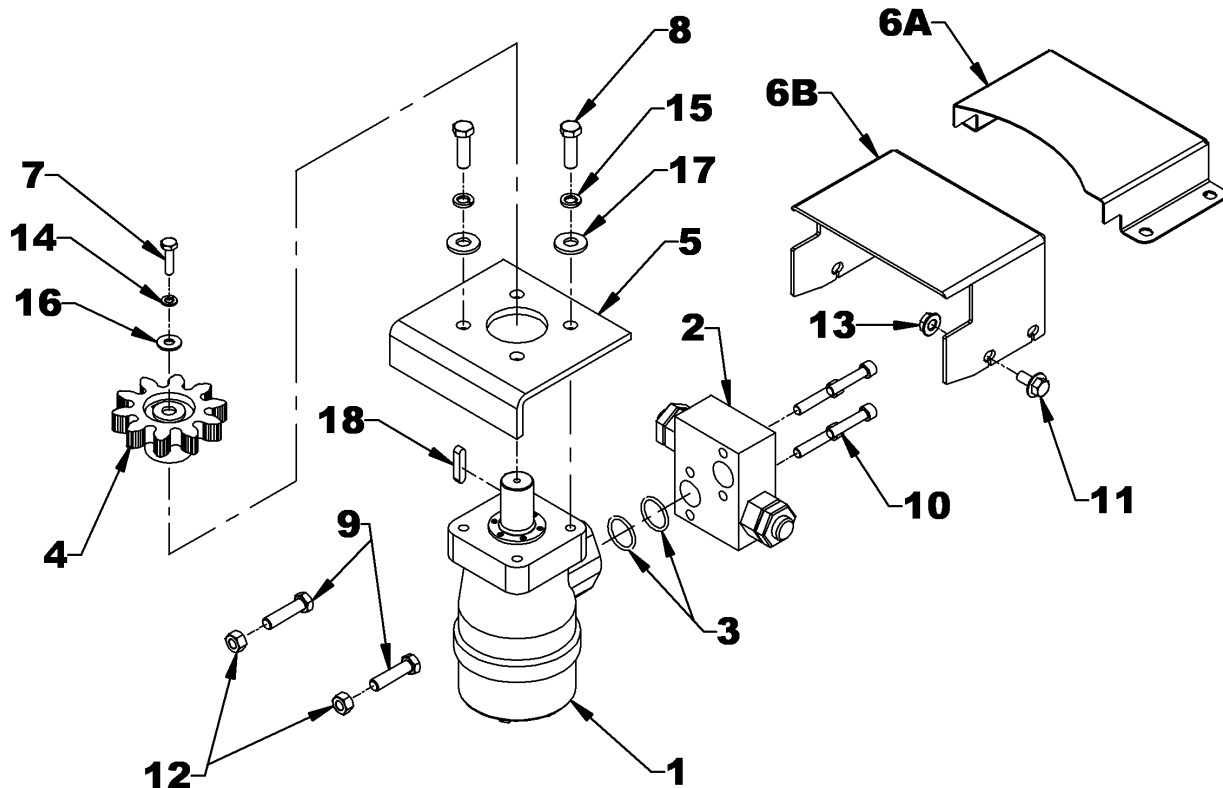

# PARTS

## HYDRAULIC VALVE FOR CHUTE ROTATION – 8183A

REF.	DESCRIPTION	QTY	PART #
1	Elbow 90° 7/8" ORBM x 9/16 X 18 JICM	2	2600106
2	Hose 59" lg – 9/16" JIC SWF x 7/16" JIC SWF	2	3700165
3	Bolt hex. ø3/8"NC x 1 1/4" Gr.5 PTD	1	0100039
4	Hose clamp 1/4"	1	666583
5	Nylon insert locknut ø3/8"NC PTD	1	1000006
6	Elbow 90° 7/16 ORB M X 7/16 JIC M	2	2600065
7	Electric valve	1	3900027
8	Allen socket head cap screw 10-24 NC x 1 3/4" gr.5, black, cylindr.	4	0800018
9	O-ring 0.07" x 3/8" x 1/2" ext.	4	3900462
10	Hose plastic guard 4" lg.	1	669152
11	Switch box	1	669281
12	Switch with rotation decal	1	669255
13	Connector tap	1	656665
14	Female connector three cavity	1	4000066
15	Male terminal	3	663282
16	Electric harness 160"	1	4000078
17	Negative wire (black) 200"	1	669314
18	Positive wire (white) 200"	2	669313
19	Wire with fuse	1	666065
20	Loom 360"	1	669315

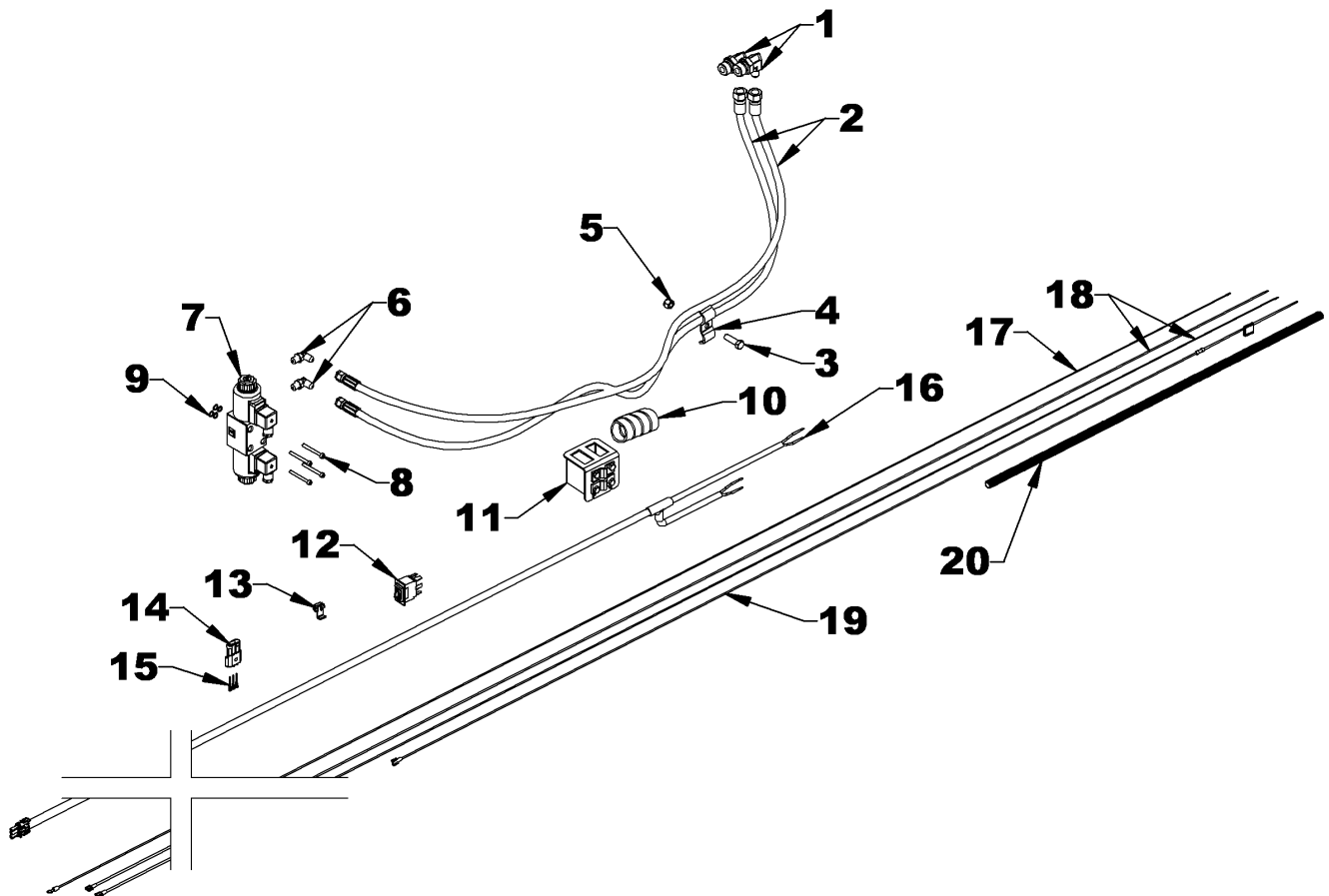

---

# PARTS

---

## HYDRAULIC VALVE FOR HYDRAULIC DEFLECTOR – 8184A

---

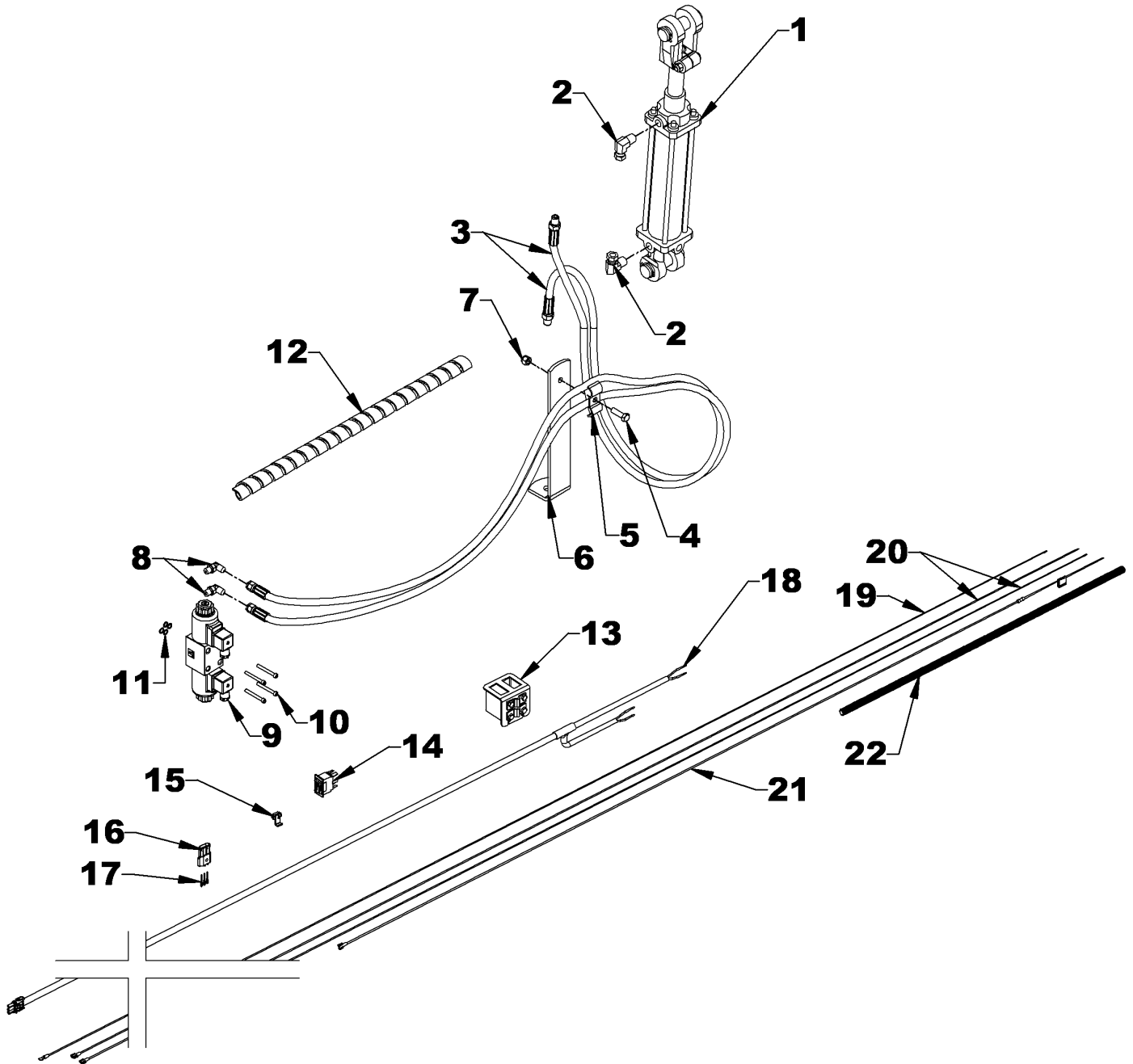

---

# PARTS

---

## HYDRAULIC VALVE FOR HYDRAULIC DEFLECTOR – 8184A

REF.	DESCRIPTION	QTY	PART #
	<b>Cylinder 8249 for H76A &amp; H84A</b>		
1	Cylinder 2" x 8"	1	3900022
	Seal kit - cylinder 3900022 (not illustrated)		3900205
	<b>Cylinder 8155 for H64A</b>		
1	Cylinder 2" x 6"	1	3900002
	Seal kit - cylinder 3900002 (not illustrated)		2600047
2	Elbow 90° 3/8" NPT M x 1/4" NPT SWF	2	654438
3	Hose 75" lg - 1/4"NPT SM x 7/16" JIC SWF	2	3700077
4	Bolt hex. ø3/8"NC x 1 1/4" Gr.5 PTD	1	0100039
5	Hose clamp 1/4"	1	666583
6	Hose support	1	669275
7	Nylon insert locknut ø3/8"NC PTD	1	1000006
8	Elbow 90° 7/16 ORB M X 7/16 JIC M	2	2600065
9	Electric valve	1	3900027
10	Allen socket head cap screw 10-24 NC x 1 3/4" gr.5, black, cylindr.	4	0800018
11	O-ring 0.07" x 3/8" x 1/2" ext.	4	3900462
12	Hose plastic guard 4" lg.	1	669152
13	Switch box	1	669281
14	Switch with rotation decal	1	669255
15	Connector tap	1	656665
16	Female connector three cavity	1	4000066
17	Male terminal	3	663282
18	Electric harness 160"	1	4000078
19	Negative wire (black) 200"	1	669314
20	Positive wire (white) 200"	2	669313
21	Wire with fuse	1	666065
22	Loom 360"	1	669315

# PARTS

## UNIVERSAL HITCH - 8153

REF.	DESCRIPTION	QTY	PART #
1	Hitch	1	665881
2	Hitch arm	2	665882
3	Upper bracket	1	665883
4	Bolt hex. 3/4" NC x 6", PTD gr.5	2	0100128
5	Bolt hex. 3/4" NC x 3 1/2", PTD gr.5	2	0100122
6	Bolt hex. 5/8" NC x 2", PTD gr.5	1	0100095
7	Bolt hex. 5/8" NC x 1 1/2", PTD gr.5	1	0100093
8	Lockwasher 5/8", PTD	2	1200007
9	Lockwasher 3/4", PTD	4	1200008
10	Nut hex. 5/8" NC, PTD	2	0900007
11	Nut hex. 3/4" NC, PTD	4	0900008

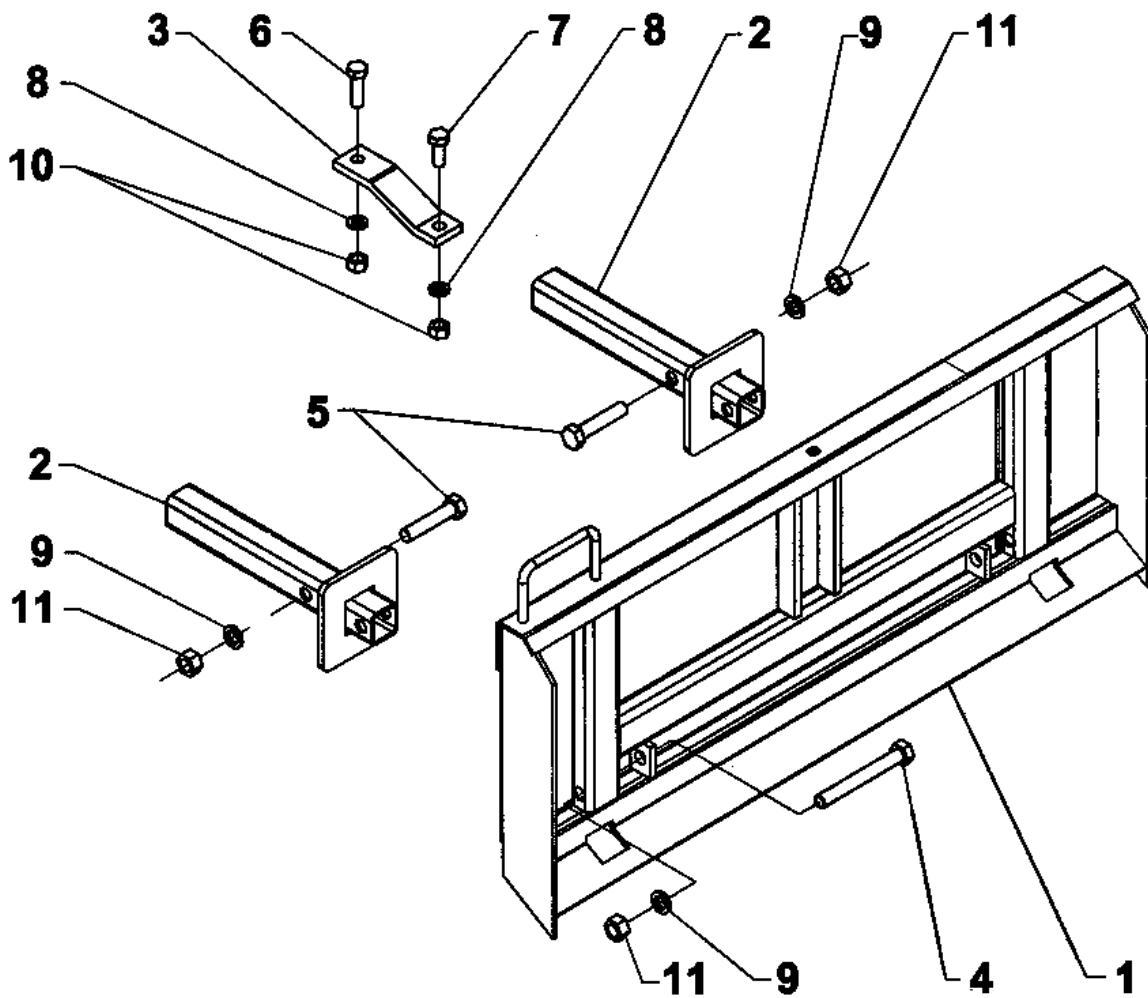

# PARTS

## DRIFT CUTTERS – 8152

REF.	DESCRIPTION	QTY	PART #
1	Left drift cutter	1	665874
2	Right drift cutter	1	665879
3	Bolt hex. 3/8"NC x 1", PTD, gr.5	2	0100038
4	Bolt hex. 5/16"NC x 1", PTD, gr.5	1	0100019
5	Bolt hex 1/2"NC x 1 1/4", PTD, gr.5	1	0100069
6	Lockwasher 3/8", PTD	2	1200004
7	Lockwasher 5/16", PTD	1	1200003
8	Lockwasher 1/2", PTD	1	1200006
9	Nut hex. 3/8"NC, PTD	2	0900003
10	Nut hex. 5/16"NC, PTD	1	0900002
11	Nut hex. 1/2"NC, PTD	1	0900006

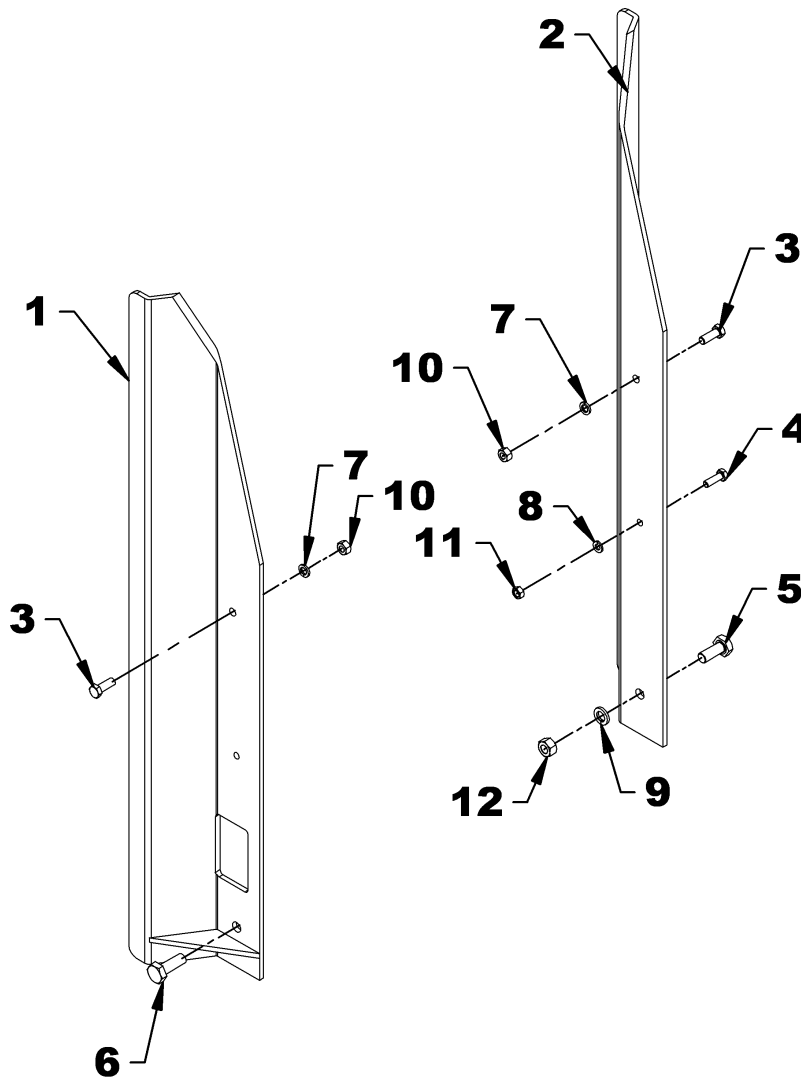

# PARTS

## ELECTRIC DEFLECTOR - 8154

REF.	DESCRIPTION	QTY	PART #								
1	Electric actuator	1	665573								
2	Switch box	1	666048								
3	Switch	1	663383								
4	Rubber cap	1	658666								
5	Plastic cap	1	662530								
6	Clevis – rod end	1	666049								
7	Clevis – fixed end	1	666051								
8	Pin 1"	2	666057								
9	Ground wire 72" (black)	1	666054								
10	Tap connector	1	656665								
11	Fuse wire 72" (red)	1	666055								
12	Actuator wire	1	666056								
13	Spring pin 3/16" x 1 3/4", PTD	2	1600009								
14	Hairpin 4mm x 80mm, PTD	2	1800002								
15	Self-drilling screw #10 x 1/2", PTD	4	3200011								
16	Bolt hex. 1/2"NC x 2 1/2", PTD	2	0100076	17	Nylon insert locknut 1/2"NC, PTD	2	1000011	18	Loom	1	666053
17	Nylon insert locknut 1/2"NC, PTD	2	1000011								
18	Loom	1	666053								

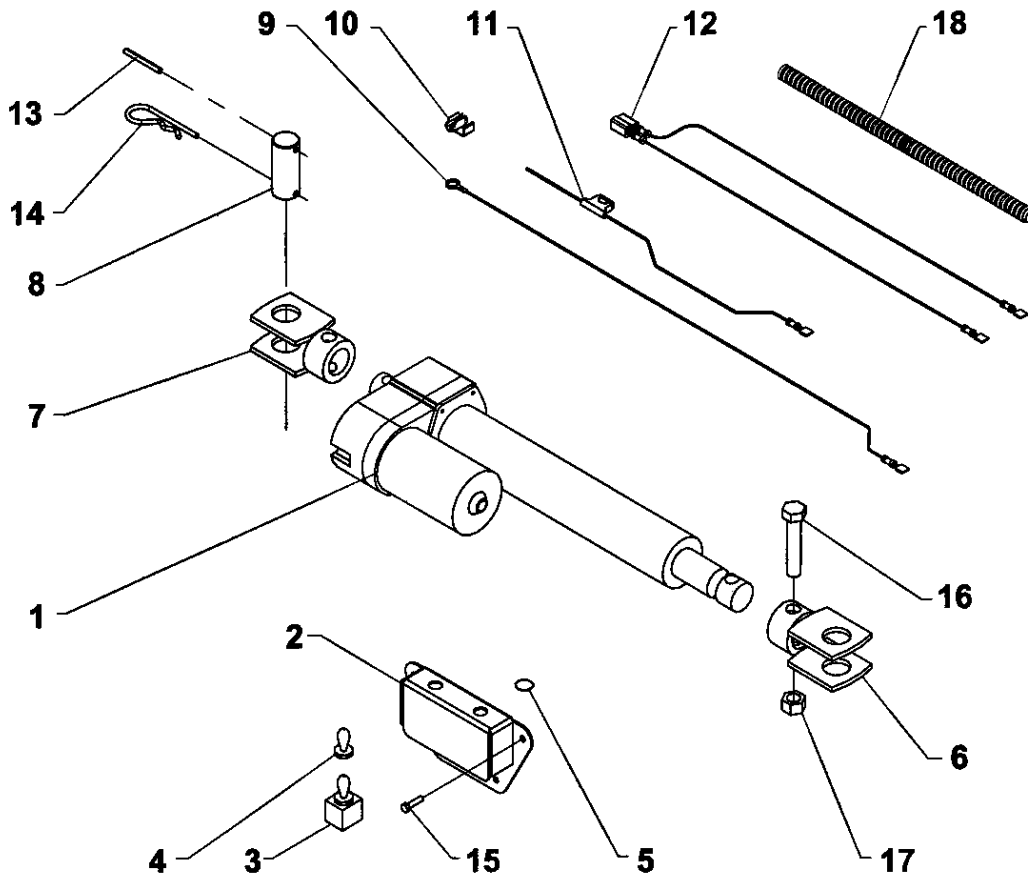

# PARTS

## SWITCH BOX KIT- 669285

REF.	DESCRIPTION	QTY	PART #
1	Switch box assembly	1	669285
2	Switch box	1	669281
3	Switch box clamp	2	667558
4	Bolt hex. $\varnothing 1/4$ "NC x $3/4$ " gr.5 PTD	4	0100003

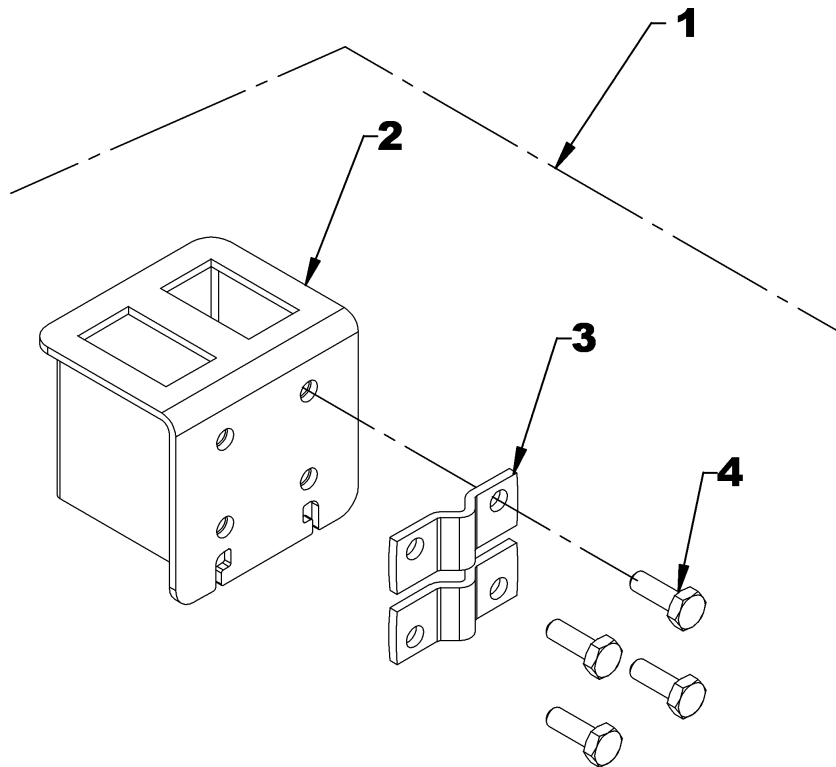

# PARTS

## HYDRAULIC MOTORS – 3910021, 3910022, 3910058 & 3910059

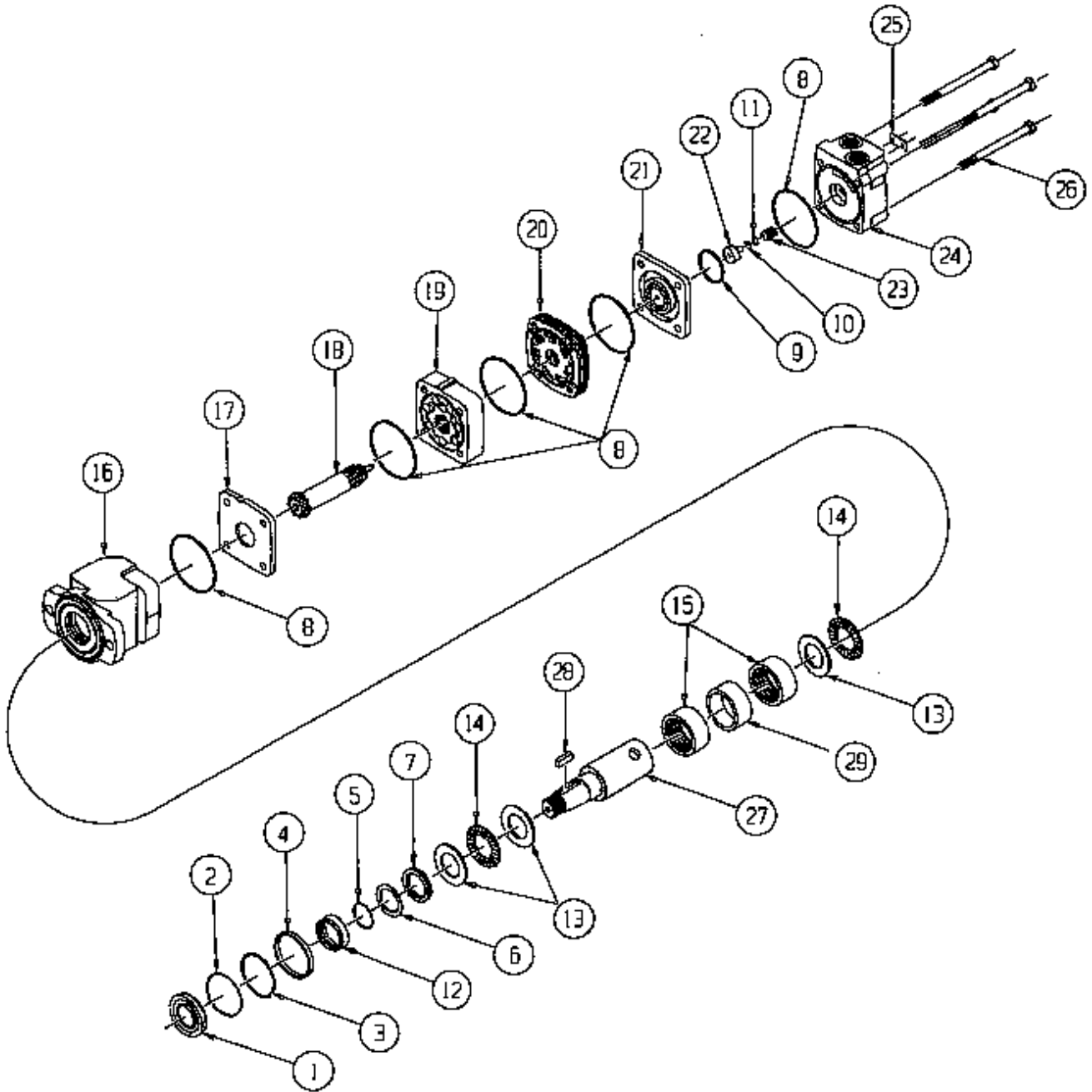

# PARTS

## **HYDRAULIC MOTORS – 3910021, 3910022, 3910058 & 3910059**

REF.	DESCRIPTION	QTY	PART #
	Seal Kit (Includes #1 to 11)		3900042
1	Dust seal	1	----
2	Retaining ring	1	----
3	Backup shim	1	----
4	High pressure seal	1	----
5	Backup shim	1	----
6	Teflon backup seal	1	----
7	Shaft seal	1	----
8	Body seal	5	----
9	Collector seal	1	----
10	O-Ring seal	1	----
11	Teflon backup seal	1	----
12	Seal carrier	1	3900132
13	Thrust washer	3	3900044
14	Thrust bearing	2	3900045
15	Housing bearing	2	3900046
16	Housing Kit, (includes #13-14-15-29)	1	3900047
17	Wear plate	1	3900133
18	Drive link kit for 3910021	1	3900049
	Drive link kit for 3910022	1	3900051
	Drive link kit for 3910058	1	3900048
	Drive link kit for 3910059	1	3900050
19	Rotor for 3910021	1	3900053
	Rotor for 3910022	1	3900055
	Rotor for 3910058	1	3900052
	Rotor for 3910059	1	3900054
20	Collector	1	3900056
21	Commutator assembly	1	3900057
22	End cover piston	1	3900059
23	Piston spring	1	3900060
24	End cover (includes #10-11-22-23)	1	3900063
25	Serial number plate	1	---
26	Bolt set kit (4) for 3910021	1	3900065
	Bolt set kit (4) for 3910022	1	3900067
	Bolt set kit (4) for 3910058	1	3900064
	Bolt set kit (4) for 3910059	1	3900066
27	Shaft 1 1/4"	1	3900068
28	Key	1	3900069
29	Bearing spacer	1	3900071

---

# WARRANTY

---



RADTECH warrants to the original buyer that the equipment is free from defects in material and workmanship. RADTECH's obligation, under this warranty, will be limited to the repair or replacement of any non-wear part or component, which RADTECH finds to be defective within **one year** from the date of original purchase (unless otherwise-specified). The applicable warranty period for commercial or rental use shall be ninety (90) days from the date of purchase

In no event shall RADTECH be liable for consequential, special, direct or indirect damages incurred by the buyer/user.

All components not manufactured by RADTECH (such as motors, actuators, hydraulic components, tires, ...etc.) are covered by the original manufacturer's warranty in conjunction with RADTECH

RADTECH's obligation under this warranty shall be limited to repairing or replacing, free of charge to the original purchaser, any part that, in RADTECH's judgment, shall show evidence of such defect, provided the **distributor** returns the part prepaid within thirty (30) days from date of failure.

This warranty shall not be interpreted to render RADTECH liable for injuries or damages of any kind or nature to person or property. This warranty does not extend to losses because of delays, or to any expenses or losses incurred for labor, substitute machinery, rental or for any other reason.

Except as set forth above, RADTECH shall have no obligation or liability of any kind on account of any of its equipment and shall not be liable for special or consequential damages. RADTECH makes no other warranty, expressed or implied, and specifically, RADTECH disclaims any implied warranty or merchantability or fitness for a particular purpose. **Some states or provinces do not permit limitations or exclusions of implied warranties or incidental or consequential damages, so the limitations or exclusions in this warranty may not apply.**

This warranty is subject to any existing conditions of supply, which may directly affect our ability to obtain materials or manufacture replacement parts. RADTECH reserves the right to make improvements in design or changes in specifications at any time, without incurring any obligation to owners of units previously sold.

No one is authorized to alter, modify or enlarge this warranty nor the exclusions, limitations and reservations.

**2835 Chemin de l'Aéroport, Thetford Mines (Québec) G6G 5R7**

Tel.: (418) 338-4499 Fax: (418) 388-6090  
Internet : [www.radinter.com](http://www.radinter.com) e-mail : [radtech@radinter.com](mailto:radtech@radinter.com)

# TORQUE SPECIFICATION TABLE

## GENERAL SPECIFICATION TABLE

Use the following torques when special torques are not given

**NOTE:** These values apply to fasteners as received from supplier, dry, or when lubricated with normal engine oil. They do not apply if special graphited or moly sidulphide greases or other extreme pressure lubricants are used. This applies to both UNF and UNC threads.

BOLT HEAD IDENTIFICATION MARKS AS PER GRADE NOTE: MANUFACTURING MARKS WILL VARY.													
		Torque		Torque		Torque		Torque					
BOLT SIZES		Pounds-Foot		Newtons-Meter		Pounds-Foot		Newtons-Meter		Pounds-Foot		Newtons-Meter	
Inches	Millimeters	MIN.	MAX.	MIN.	MAX.	MIN.	MAX.	MIN.	MAX.	MIN.	MAX.	MIN.	MAX.
1/4	6.35	5	6	6.8	8.13	9	11.0	12.2	14.9	12	15	16.3	30.3
5/16	7.94	10	12	13.6	16.3	17	20.5	23.1	27.8	24	29	32.5	39.3
3/8	9.53	20	23	27.1	31.2	35	42.0	47.5	57.0	45	54	61.0	73.2
7/16	11.11	25	30	40.7	47.4	54	64.0	73.2	86.8	70	84	94.9	113.9
1/2	12.70	45	52	61.0	70.5	80	96.0	108.5	130.2	110	132	149.2	179.0
9/16	14.29	65	75	88.1	101.6	110	132.0	149.2	179.0	160	192	217.0	260.4
5/8	15.88	95	105	128.7	142.3	150	180	203.4	244.1	220	264	298.3	358.0
3/4	19.05	150	185	203.3	250.7	270	324	366.1	439.3	380	456	515.3	618.3
7/8	22.23	160	200	216.8	271.0	400	480	542.4	650.9	600	720	813.6	976.3
1	25.40	250	300	338.8	406.5	580	696	786.5	943.8	900	1080	1220.4	1464.5
1 1/8	25.58	-	-	-	-	800	880	1084.8	1193.3	1280	1440	1735.7	1952.6
1 1/4	31.75	-	-	-	-	1120	1240	1518.7	1681.4	1820	2000	2467.9	2712.0
1 3/8	34.93	-	-	-	-	1460	1680	1979.8	2278.1	2380	2720	3227.3	3688.3
1 1/2	38.10	-	-	-	-	1940	2200	2630.6	2983.2	3160	3560	4285.0	4827.4

## METRIC BOLT TORQUE SPECIFICATIONS

Size of screw	Grade No.	Pitch (mm)	Coarse thread				Fine Thread			
			Pounds-Foot		Newtons-Meter		Pounds-Foot		Newtons-Meter	
			MIN.	MAX.	MIN.	MAX.	MIN.	MAX.	MIN.	MAX.
M6	4T	1.0	3.6	5.8	4.9	7.9	-	-	-	-
	7T		5.8	9.4	7.9	12.7	-	-	-	-
	8T		7.2	10	9.8	13.6	-	-	-	-
M8	4T	1.25	7.2	14	9.8	19.0	12	17	16.3	23.0
	7T		17	22	23	29.8	19	27	25.7	36.6
	8T		20	26	27.1	35.2	22	31	29.8	42
M10	4T	1.5	20	25	27.1	33.9	20	29	27.1	39.3
	7T		34	40	46.1	54.2	35	47	47.4	63.7
	8T		38	46	51.5	62.3	40	52	54.2	70.5
M12	4T	1.75	28	34	37.9	46.1	31	41	42	55.6
	7T		51	59	69.1	79.9	56	68	75.9	92.1
	8T		57	66	77.2	89.4	62	75	84	101.6
M14	4T	2.0	49	56	66.4	75.9	52	64	70.5	86.7
	7T		81	93	109.8	126	90	106	122	143.6
	8T		96	109	130.1	147.7	107	124	145	168
M16	4T	2.0	67	77	90.8	104.3	69	83	93.5	112.5
	7T		116	130	157.2	176.2	120	138	162.6	187
	8T		129	145	174.8	196.5	140	158	189.7	214.1
M18	4T	2.0	88	100	119.2	136	100	117	136	158.5
	7T		150	168	203.3	227.6	177	199	239.8	269.6
	8T		175	194	237.1	262.9	202	231	273.7	313
M20	4T	2.5	108	130	146.3	176.2	132	150	178.9	203.3
	7T		186	205	252	277.8	206	242	279.1	327.9
	8T		213	249	288.6	337.4	246	289	333.3	391.6

# TORQUE SPECIFICATION TABLE

## **TORQUE SPECIFICATION TABLE FOR HYDRAULIC FITTINGS**

Use the following torques when a specific torque is not given. Note: These values apply to fittings when dry. These values do not apply if lubricants are used..

SIZE OF FITTINGS	TORQUE	
	foot-pounds	Newton-meters
<b>SIZE ( JIC ) - INCHES</b>		
<b>03 - 3/8" - 24</b>	<b>8-9</b>	<b>12-13</b>
<b>04 - 7/16" - 20</b>	<b>13-15</b>	<b>18-20</b>
<b>05 - 1/2" - 20</b>	<b>14-15</b>	<b>19-21</b>
<b>06 - 9/16" - 18</b>	<b>23-24</b>	<b>32-33</b>
<b>08 - 3/4" - 16</b>	<b>40-43</b>	<b>55-57</b>
<b>10 - 7/8" - 14</b>	<b>43-48</b>	<b>59-64</b>
<b>12 - 1 1/16" - 12</b>	<b>68-75</b>	<b>93-101</b>
<b>14 - 1 3/16" - 12</b>	<b>83-90</b>	<b>113-122</b>
<b>16 - 1 5/16" - 12</b>	<b>112-123</b>	<b>152-166</b>
<b>20 - 1 5/8" - 12</b>	<b>146-161</b>	<b>198-218</b>
<b>24 - 1 7/8" - 12</b>	<b>154-170</b>	<b>209-230</b>
<b>32 - 2 1/2" - 12</b>	<b>218-240</b>	<b>296-325</b>

SIZE ( ORB ) - INCHES	foot-pounds	Newton-meters
<b>03 - 3/8" - 24</b>	<b>8-10</b>	<b>11-13</b>
<b>04 - 7/16" - 20</b>	<b>14-16</b>	<b>20-22</b>
<b>05 - 1/2" - 20</b>	<b>18-20</b>	<b>24-27</b>
<b>06 - 9/16" - 18</b>	<b>24-26</b>	<b>33-35</b>
<b>08 - 3/4" - 16</b>	<b>50-60</b>	<b>68-78</b>
<b>10 - 7/8" - 14</b>	<b>72-80</b>	<b>98-110</b>
<b>12 - 1 1/16" - 12</b>	<b>125-135</b>	<b>170-183</b>
<b>14 - 1 3/16" - 12</b>	<b>160-180</b>	<b>215-245</b>
<b>16 - 1 5/16" - 12</b>	<b>200-220</b>	<b>270-300</b>
<b>20 - 1 5/8" - 12</b>	<b>210-280</b>	<b>285-380</b>
<b>24 - 1 7/8" - 12</b>	<b>270-360</b>	<b>370-490</b>

---

# TORQUE SPECIFICATION TABLE

---

SIZE ( NPT ) - INCHES	Torque FFT
<b>1/8" - 27</b>	<b>2.0 - 3.0</b>
<b>1/4" - 18</b>	<b>2.0 - 3.0</b>
<b>3/8" - 18</b>	<b>2.0 - 3.0</b>
<b>1/2" - 14</b>	<b>2.0 - 3.0</b>
<b>3/4" - 16</b>	<b>2.0 - 3.0</b>
<b>1" - 11 1/2"</b>	<b>1.5 - 2.5</b>
<b>1 1/4" - 11 1/2"</b>	<b>1.5 - 2.5</b>
<b>1 1/2" - 11 1/2"</b>	<b>1.5 - 2.5</b>

## ASSEMBLY

The method used to assemble fittings with NPT threads is in two stages. First tighten firmly by hand then tighten one again according to the number of turns listed on the above table. The following method is recommended to minimize the risks of leaks and/or damages to the parts.

1. Inspect threads and tapping to make sure they are clean.
2. Apply a sealant/lubricant product to the NPT threads (Teflon covered threads are preferable to other lubricating products). If PTFE tape (Teflon) is used, make 1,5 or 2 turns clockwise.

**Attention: More than 2 turns can cause distortion or cracks in the orifice.**

3. Tighten the fitting by hand.

4. Screw the fitting the number of turns listed on the above table making sure that in the case of a shape fitting the end is aligned to the desired position. **Never unscrew a fitting to obtain the proper alignment.**
5. If the leak persists after having followed the preceding instructions, check that the threads are not damaged and the number of seated threads.

If the threads are very damaged, replace the fitting. If the tapping is damaged, retap if possible or replace the part.

Usually, the number of threads seated is between 3, 5 and 6. If the range is different it would indicate that the fitting was tightened too much or not enough or that the tightening was not within thread tolerances. If the fitting is not tight enough, tighten but never more than one turn. If it's too tight, control the threading and tapping and replace the section that has threads that are not within tolerances.





Manufactured by:



***RAD TECHNOLOGIES INC.***

***Division Thetford Mines***

2835, Chemin de l'Aéroport

Thetford Mines, Québec, Canada, G6G 5R7

Tel.: (418) 338-4499 - Fax.: (418) 338-6090

**E-mail :** [radtech@radinter.com](mailto:radtech@radinter.com)

**Internet :** [www.radinter.com](http://www.radinter.com)

Printed in Canada