

BER-VAC

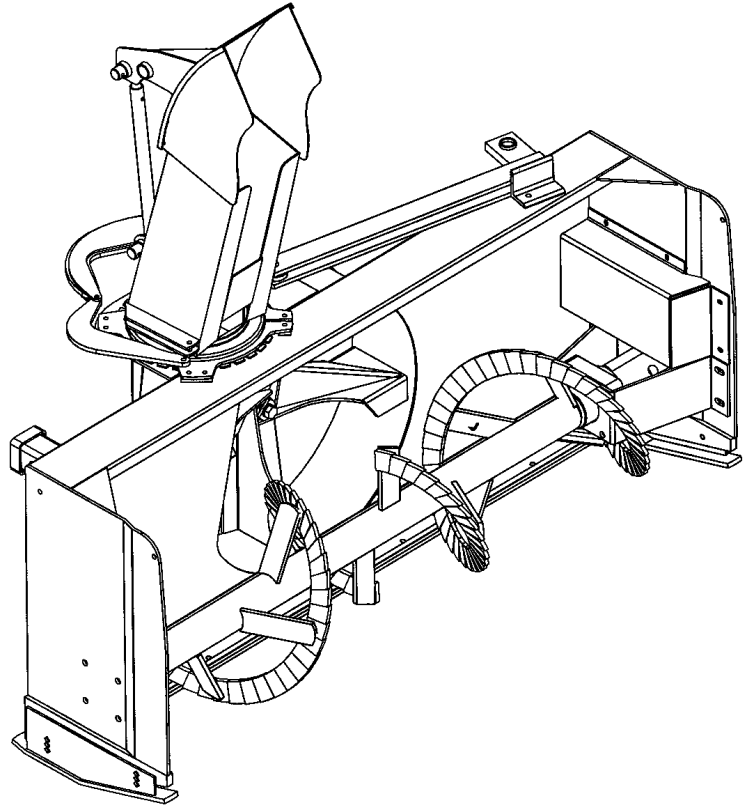

OPERATOR'S MANUAL

64" HYDRAULIC SNOWBLOWER – H64A
76" HYDRAULIC SNOWBLOWER – H76A
84" HYDRAULIC SNOWBLOWER – H84A

SERIAL NO. 2704690 AND UP

OM 0303SB-A
12/09



TABLE OF CONTENT

INTRODUCTION – TO THE PURCHASER.....	3
SAFETY PRECAUTIONS	
Before Operation.....	4
Notice.....	5
The Snowblower.....	5
Before Operation.....	5
Snowblower Operation.....	6
The Tractor.....	7
General Information.....	7
Operating the Tractor.....	7
During Operation.....	8
Roll-Over Protective Structure (ROPS).....	8
Maintenance.....	9
Transporting.....	10
Storage.....	10
DECALS.....	11
OPERATION PARAMETERS.....	13
ASSEMBLY.....	15
Hydraulic Hoses Installation.....	15
Chute & Skid shoes Installation for H64A.....	16
Chute & Skid shoes Installation for H76A & H84A.....	17
Chute Rotation for H64A.....	18
Chute Rotation for H76A & H84A.....	19
Universal Hitch Installation - 8153.....	20
Drift Cutters Installation -8152.....	21
Hydraulic Rotation - 8183A.....	22
Hydraulic Deflector - 8184A.....	25
Electric Rotation & Deflector - 8151.....	30
Electric Deflector 8154.....	32
OPERATION.....	34
General Preparation.....	34
Operating Controls.....	34
Manual Deflector Adjustment.....	34
Hydraulic or Electric Deflector Adjustment.....	34
Hydraulic or Electric Rotation Adjustment.....	34
Work & Travel Speed.....	34
Skid shoes Adjustment.....	34
Snow Removal Method.....	36

TABLE OF CONTENT

MAINTENANCE	37
Maintenance	37
Storage	37
Hydraulic System Oil	37
Lubrication	38
Regular Inspections.....	38
Troubleshooting.....	39
Adjustment of the V.A.C. System	41
Specifications	42
WARRANTY	43
TORQUE SPECIFICATION TABLE	44

INTRODUCTION

IMPORTANT NOTICE

The Ber-Vac Hydro snowblowers are calibrated and tested at the plant in order to ensure the best possible performances. The calibration of these snowblowers requires the proper equipment and a certain expertise.

Any partial modification or adjustment made on the snowblower without the written consent of RAD Technologies inc. will result in the immediate cancellation of the snowblower's warranty.

The adjustments of the hydraulic components must never be modified. However, it might be necessary to make some adjustments, depending on the type of machine used with the snowblower. To do so, follow the instructions "Adjustment of the V.A.C. System" in the Maintenance section.

TO THE PURCHASER

All products are designed to give safe, dependable service if they are operated and maintained according to instructions. **Read and understand this manual before operation.**

Read and understand this operator's manual before attempting to put equipment into service. Familiarize yourself with the operating instructions and all the safety recommendations contained in this manual and those labeled on the equipment and on the tractor. Follow the safety recommendations and make sure that those with whom you work follow them.

Illustrations

The illustrations may not necessarily reproduce the full detail and the exact shape of the parts or depict the actual models, but are intended for reference only.

Direction Reference

All references to right and left, forward or rearward, are from the operator's seat, facing the steering wheel.

To assist your dealer in handling your needs, please record hereafter the model number and serial number of your equipment and tractor. It is also advisable to supply them to your insurance company. It will be helpful in the event that an equipment or tractor is lost or stolen.

TRACTOR

IMPLEMENT

MODEL:

SERIAL NUMBER:

DATE OF PURCHASE:

DEALER NAME:

SAFETY PRECAUTIONS



SAFETY FIRST

This symbol, the industry's "Safety Alert Symbol", is used throughout this manual and on labels on the machine itself to warn of the possibility of personal injury. Read these instructions carefully. It is essential that you read the instructions and safety regulations before you attempt to assemble or use this unit.

 **DANGER :** Indicates an immediate hazardous situation which, if not avoided, will result in death or serious injury.

 **WARNING :** Indicates a potentially hazardous situation which, if not avoided, could result in death or serious injury.

 **CAUTION :** Indicates a potentially hazardous situation which, if not avoided, may result in minor or moderate injury.

IMPORTANT : Indicates that equipment or property damage could result if instructions are not followed.

NOTE : Gives helpful information.

All products are designed to give safe, dependable service if they are operated and maintained according to instructions. **Read and understand this manual before operation.** It is the owner's responsibility to be certain anyone operating this product reads this manual, and all other applicable manuals, to become familiar with this equipment and all safety precautions. Failure to do so could result in serious personal injury or equipment damage. If you have any questions, consult your dealer.

BEFORE OPERATION

Children

Tragic accidents can occur if the operator is not alert to the presence of children. Children are generally attracted to machines and the work being done. Never assume children will remain where you last saw them.

1. Keep children out of the operating area and under the watchful eye of another responsible adult.
2. Be alert and turn machine off if children enter the work area.
3. Before and when backing, look behind for small children.
4. Never carry children while operating the machine. They may fall off and be seriously injured or interfere with the safe operation of the machine.
5. Never allow children to play on the machine or attachment even when they are turned off.
6. Never allow children to operate the machine even under adult supervision.
7. Use extra care when approaching blind corners, shrubs, trees, or other obstructions that might hide children from sight.

SAFETY PRECAUTIONS - continued

NOTICE

A safe operator is the best assurance against accidents. All operators, no matter how experienced they may be, should read this operator's manual and all other related manuals before attempting to operate the equipment. Please read the following section and pay particular attention to all safety recommendations contained in this manual and those labeled on the equipment and on the tractor.

THE SNOWBLOWER

Before Operation

1. Read and understand this operator's manual and tractor operator's manual. Know how to operate all controls and how to stop the unit and disengage the controls quickly.
2. Never wear loose, torn, or bulky clothing around the tractor and the snowblower. It may catch on moving parts or controls, causing injury.
3. Before and during the snow season, thoroughly inspect the area where the equipment is to be used and remove all objects that may be thrown or cause damage to the equipment.
4. Set transmission to neutral and disengage clutch, if equipped, before starting the engine.
5. Do not operate equipment in wintertime without wearing adequate winter garments and protective clothing.
6. Never attempt to make any adjustments while engine is running. Read this manual carefully to acquaint yourself with the equipment as well as the tractor operator's manual. Working with unfamiliar equipment can lead to accidents. Be thoroughly familiar with the controls and proper use of the equipment.
7. Keep all safety guards in place and verify hardware for proper tightening.
8. Check for moving parts excessive wear regularly. Replace worn parts with genuine parts.
9. Replace all missing, illegible, or damaged safety and warning decals. See list of decals in operator's manual.
10. Keep safety decals clean of dirt and grime.
11. Do not modify or alter this equipment or any of its components, or any equipment function without first consulting your dealer.
12. Use of rear counterweights is recommended. Weights provide the necessary balance to improve stability, traction and steering. Use only those recommended by your dealer.

SAFETY PRECAUTIONS - continued

SNOWBLOWER OPERATION

1. Before leaving the tractor unattended, take all possible precautions. Park the tractor/snowblower on level ground, place the transmission in neutral, set the parking brake, disengage the equipment drive, lower the equipment to the ground, place all levers including auxiliary control levers in neutral, shut off the engine and remove the ignition key.
2. Before starting the tractor/ snowblower, remove any ice that has accumulated in the auger/fan.
3. Prior to operation, clear work area of all objects that can be picked up and thrown. Mark all curbs, pipes, etc. that cannot be moved.
4. Be sure the PTO switch/lever is in OFF position before starting engine.
5. Exercise extreme caution when operating on or crossing a gravel drive, walks, or roads. Stay alert for hidden hazards or traffic.
6. Do not carry passengers.
7. Adjust collector-housing height to clear gravel or crushed rock surface.
8. Keep clear of rotating parts. Do not put hands or feet under, or into snowblower with engine running.
9. Park the tractor/snowblower on level ground, place the transmission in neutral, set the parking brake, disengage the equipment drive, lower the equipment to the ground, place all control levers in neutral, shut off the engine, remove the ignition key and allow the rotating parts to stop BEFORE unclogging the collector/fan housing or chute, and making any repairs, adjustments or inspections. Use only a 36" long piece of wood to unclog blower.
10. If the snowblower starts to vibrate abnormally, disengage the equipment drive, stop the engine immediately and check for cause. Excessive vibration is generally a sign of trouble.
11. Do not run the engine indoors except when starting engine and transporting attachment in or out of building. Carbon monoxide gas is colorless, odorless and deadly.
12. Do not attempt to operate on steep slopes. If operating on slopes is necessary, exercise extreme caution when changing direction.
13. Never operate snowblower without guards, and other safety protective devices in place.
14. Keep clear of chute discharge. This chute has the capability of throwing objects at far distances.
15. Never operate snowblower near glass enclosures, automobiles, window wells, embankments, etc., without proper adjustment of snow discharge angle.
16. Never operate machine at high transport speeds on a slippery surface.
17. Use extra caution when backing up.
18. Do not direct discharge at bystanders or animals. Ejected objects may cause injury.
19. Disengage power to auger/fan when transporting or when not in use.
20. Never operate the snowblower without good visibility and lighting.
21. Prolonged exposure to loud noise can cause impairment or loss of hearing. Wear a suitable hearing protective device such as earmuffs or earplugs to protect against objectionable or uncomfortable noises.
22. Never allow anyone near the work area.

SAFETY PRECAUTIONS - continued

THE TRACTOR

General Information

1. Read the operator's manual carefully before using tractor. Lack of operating knowledge can lead to accidents.

2. Do not permit anyone but the operator to ride on the tractor. There is no safe place for passengers.

Operating the Tractor

1. Never run the tractor engine in a closed building without adequate ventilation, as the exhaust fumes are very dangerous.

14. Fill fuel tank outdoors with extreme care. Never fill fuel tank indoors. Replace fuel cap securely and wipe up spilled fuel.

2. Adopt safe driving practice. If so equipped, keep the brake pedals latched together at all times unless independent braking is required. Never use independent braking during transport.

15. Never allow anyone to operate the snowblower until they have read the manual completely and are thoroughly familiar with basic tractor and snowblower operation.

3. Always drive at a safe speed relative to local conditions and ensure that your speed is low enough for an emergency stop to be safe and secure.

16. Make sure the tractor is counterweighted as recommended by your dealer. Weights provide the necessary balance to improve stability, traction and steering.

4. Reduce speed prior to turns to avoid the risk of overturning. Keep speed to a minimum.

17. Always make sure all snowblower components are properly installed and securely fastened BEFORE operation.

5. Always keep the tractor in gear to provide engine braking when going downhill. Do not coast.

18. Never attempt to start the engine and/or engage snowblower drive while standing beside the tractor.

6. Never allow an open flame near the fuel tank or battery.

19. Always start the engine from the operator's seat with all the transmission lever(s) and snowblower drive lever in neutral.

7. Park the tractor/snowblower on level ground, place the transmission in neutral, set the parking brake, disengage the equipment drive, lower the equipment to the ground, place all levers including auxiliary control levers in neutral, shut off the engine and remove the ignition key BEFORE leaving the tractor.

20. DO NOT bypass the safety system by shorting across the terminals of the starter motor to start the engine. This may cause the tractor to move suddenly.

8. Never park the tractor on a steep slope.

21. If the safety start system does not work, consult your dealer immediately.

9. Do not attempt to operate on steep slopes. Avoid sudden uphill turns on steep slopes.

10. Use of rear counterweights for better traction and stability is recommended.

11. Handle fuel with care, as it is highly flammable.

12. Use approved fuel container.

13. Never add fuel to a running engine or a hot engine.

SAFETY PRECAUTIONS - continued

During Operation

1. Do not allow passengers on the tractor/snowblower at any time. There is no safe place for passengers on this equipment. The operator **MUST** sit in the tractor seat.
2. Eye and hearing protection is recommended when operating the snowblower.
3. Operate only during daylight hours, or when the area is well lit with bright artificial light.
4. Park the tractor/snowblower on level ground, place the transmission in neutral, set the parking brake, disengage the PTO, lower the equipment to the ground, place all control levers in neutral, shut off the engine and remove the ignition key **BEFORE** leaving the operator's seat.
5. Inspect the snowblower after striking any foreign object to assure that all snowblower parts are safe and secure and not damaged.
6. Be especially observant of the operating area and terrain. Watch for holes, rocks, or other hidden hazards. **ALWAYS** inspect the area prior to blowing.
7. **DO NOT** blow near the edge of drop-offs or banks.
8. **DO NOT** blow on steep slopes as overturn may result.
9. Operate up and down (not across) intermediate slopes. Avoid sudden starts and stops.
10. Drive tractor backwards up steeper slopes with blower off. Then blow as you travel down the slope.
11. Slow down before you change directions on any slope.
12. Use wheel weights on your tractor to increase stability on slopes.
13. Never stand alongside of the unit while the engine is running.

Roll-Over Protective Structure (ROPS) (If so equipped)

1. **DO NOT** weld, drill or alter the ROPS. Damaged ROPS must not be straightened or used. If damage does occur, consult your dealer.
2. If the ROPS is lowered or removed from the tractor for any reason, it must be erected and/or refitted immediately. Original bolts or equivalent replacements must be used and tightened to the correct torque.
3. Your dealer does not recommend usage of tractor with ROPS removed.
4. If a fold-down ROPS is used, the ROPS can be folded down for storage, but it must be pinned in the upright position prior to operation.
5. Seat belt usage: With ROPS installed on the tractor it is imperative that the seat belt be installed, used and correctly adjusted, at all times. **DO NOT** use a seat belt if operating without ROPS.
6. Additional safety equipment: A fire extinguisher and first aid kit should be kept readily accessible..

SAFETY PRECAUTIONS - continued

MAINTENANCE

ALWAYS USE GENUINE PARTS WHEN REPLACEMENT PARTS ARE REQUIRED

1. Keep the tractor and snowblower properly maintained.
2. Park the tractor/snowblower on level ground, place the transmission in neutral, set the parking brake, disengage the equipment drive, lower the equipment to the ground, place all control levers in neutral, shut off the engine and remove the ignition key and allow the rotating parts to stop **BEFORE** making any snowblower adjustments.
3. To avoid injury, do not adjust, unclog or service the snowblower with the tractor engine running. Make sure rotating components have completely stopped before leaving the operator's seat.
4. Keep the tractor/snowblower clean. Snow and ice build-up can lead to malfunction or personal injury from thawing and refreezing in garage.
5. Always wear eye protection when cleaning or servicing the snowblower.
6. Service the unit in safety: **DO NOT** service the tractor while the engine is running or hot, or if the unit is in motion. Always lower snowblower to the ground. If necessary to service unit with blower raised, securely support with stands or suitable blocking before working underneath. Do not rely on hydraulically supported devices for your safety. They can settle suddenly, leak down, or be accidentally lowered.
7. Do not attempt to service machine, clear obstructions or unplug blockages with the engine running. Always shut off engine and allow all motion to cease.
8. The manufacturer will not claim responsibility for fitment of unapproved parts and/or accessories and any damages as a result of their use.
9. Make sure all shields and guards are securely in place following all service, cleaning, or repair work.
10. Do not modify or alter this equipment or any of its components or operating functions. If you have questions concerning modifications, consult with your dealer.
11. Do not operate a unit, which is defective or has missing parts. Make sure that all recommended maintenance procedures are completed before operating the unit.
12. Check all controls regularly and adjust where necessary. Make sure that the brakes are evenly adjusted.
13. Periodically check all nuts and bolts for tightness, especially wheel hub and rim nuts.
14. Snowblower fan and auger must be checked for tightness. Remove any twine, wire, etc. that may have wrapped on the fan or the auger.
15. To avoid serious personal injury: Escaping hydraulic/diesel fluid under pressure can penetrate the skin causing serious injury. Do not use your hands to check for leaks. Use a piece of cardboard or paper to search for leaks.
16. Stop engine and relieve pressure before connecting or disconnecting lines. Tighten all connections before starting engine or pressurizing lines.

SAFETY PRECAUTIONS - continued

TRANSPORT

1. When driving the tractor and equipment on the road or highway under 25 mph, at night or during the day, use flashing amber warning lights and the Slow Moving Vehicle ("SMV") identification emblem.
2. Check local traffic codes that may apply to unit usage on public roads and highways in your area. The use of flashing amber lights is acceptable in most localities. However, some localities may prohibit their use.
3. Always disengage equipment drive prior to transporting unit.

STORAGE

Before storing the snowblower, certain precautions should be taken to protect it from deterioration.

1. Clean the snowblower thoroughly.
2. Make all the necessary repairs.
3. Replace all safety signs that are damaged, lost, or otherwise become illegible. If a part to be replaced has a sign on it, obtain a new safety sign from your dealer and install it in the same place as on the removed part.
4. Repaint all parts from which paint has worn or peeled.
5. Lubricate the snowblower as instructed under "**Lubrication**" section.
6. When the snowblower is dry, oil all moving parts. Apply oil liberally to all surfaces to protect against rust.
7. Store in a dry place.

DECALS

Replace immediately if damaged

For H64A snowblower



656779



656780

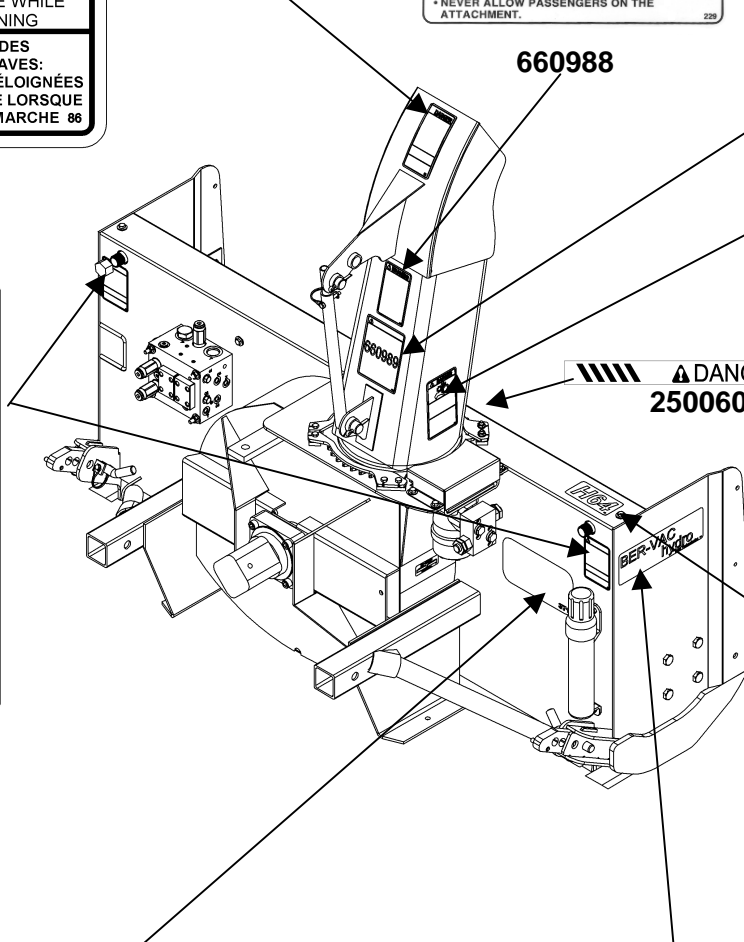
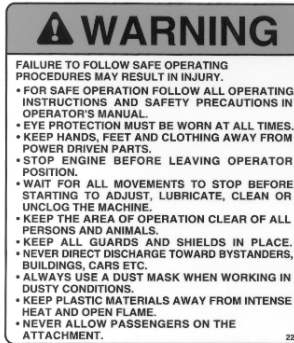

660989

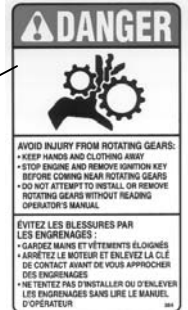

2500330



2500311



2500315



2500308

DECALS

**Replace immediately if damaged
For H76A & H84 snowblowers**

MISE EN GARDE

NÉGLIGER DE SUIVRE LES PROCÉDURES SÉCURITAIRES D'UTILISATION PEUT ENTRAÎNER DES BLESSURES.

- POUR UNE UTILISATION SÉCURITAIRE, SUIVRE TOUTES LES INSTRUCTIONS D'UTILISATION ET PRÉCAUTIONS SÉCURITAIRES DANS LE MANUEL DE L'OPÉRATEUR.
- PORTER DES LUNETTES DE SÉCURITÉ EN TOUT TEMPS.
- GARDER MAINS, PIEDS ET VÊTEMENTS ÉLOIGNÉS DES PIÈCES MOTRICES.
- ARRÊTER LE MOTEUR AVANT DE QUITTER LA POSITION DE L'OPÉRATEUR.
- ATTENDRE QUE TOUTS LES MOUVEMENTS SOIENT ARRÊTÉS AVANT D'AJUSTER, LUBRIFIER, NETTOYER OU DÉBOQUER LA MACHINE.
- GARDER L'ENDROIT D'UTILISATION DÉGAGÉ DE TOUTES PERSONNES ET ANIMAUX.
- GARDER TOUTS LES ÉCRANS PROTECTEURS EN PLACE.
- JAMAIS DIRIGER L'ÉVACUATION VERS DES PIÉTONS, BÂTIMENTS, AUTOMOBILES, ETC. TOUJOURS UTILISER UN MASQUE À POUSSIÈRE DANS UN ENVIRONNEMENT POUSSIÉREUX.
- GARDER TOUTES LES MATIÈRES PLASTIQUES ÉLOIGNÉES DE LA CHALEUR INTENSE ET DES FLAMMES.
- NE JAMAIS PERMETTRE DE PASSAGERS SUR CETTE MACHINE.

660989

WARNING

FAILURE TO FOLLOW SAFE OPERATING PROCEDURES MAY RESULT IN INJURY.

- FOR SAFE OPERATION FOLLOW ALL OPERATING INSTRUCTIONS AND SAFETY PRECAUTIONS IN OPERATOR'S MANUAL.
- EYE PROTECTION MUST BE WORN AT ALL TIMES.
- KEEP HANDS, FEET AND CLOTHING AWAY FROM POWER DRIVEN PARTS.
- STOP ENGINE BEFORE LEAVING OPERATOR POSITION.
- WAIT FOR ALL MOVEMENTS TO STOP BEFORE STARTING TO ADJUST, LUBRICATE, CLEAN OR UNLOCK THE MACHINE.
- KEEP THE AREA OF OPERATION CLEAR OF ALL PERSONS AND ANIMALS.
- KEEP ALL GUARDS AND SHIELDS IN PLACE.
- NEVER DIRECT DISCHARGE TOWARD BYSTANDERS, BUILDINGS, CARS ETC.
- ALWAYS USE A DUST MASK WHEN WORKING IN DUSTY CONDITIONS.
- KEEP PLASTIC MATERIALS AWAY FROM INTENSE HEAT AND OPEN FLAME.
- NEVER ALLOW PASSENGERS ON THE ATTACHMENT.

660988

DANGER

TO AVOID SERIOUS INJURY: KEEP HANDS OUT OF THIS DISCHARGE CHUTE WHILE ENGINE IS RUNNING

POUR ÉVITER DES BLESSURES GRAVES: GARDER LES MAINS ÉLOIGNÉES DE CETTE GOULOTTE LORSQUE LE MOTEUR EST EN MARCHÉ

656779

DANGER

AVOID INJURY FROM ROTATING GEARS:

- KEEP HANDS AND CLOTHING AWAY
- STOP ENGINE AND REMOVE IGNITION KEY BEFORE COMING NEAR ROTATING GEARS
- DO NOT ATTEMPT TO INSTALL OR REMOVE ROTATING GEARS WITHOUT READING OPERATOR'S MANUAL

ÉVITEZ LES BLESSURES PAR LES ENGRÈNAGES:

- GARDEZ MAINS ET VÊTEMENTS ÉLOIGNÉS
- ARRÊTEZ LE MOTEUR ET ENLEVEZ LA CLÉ DE CONTACT AVANT DE VOUS APPROCHER DES ENGRÈNAGES
- NÉ TENTEZ PAS D'INSTALLER OU D'ENLEVER LES ENGRÈNAGES SANS LIRE LE MANUEL D'OPÉRATEUR

2500330

DANGER

AVOID INJURY FROM ROTATING AUGER KEEP HANDS, FEET AND CLOTHING AWAY

POUR ÉVITER DES BLESSURES GRAVES: GARDER LES MAINS, LES PIEDS ET LES VÊTEMENTS ÉLOIGNÉS DES VIS SANS FIN

656780

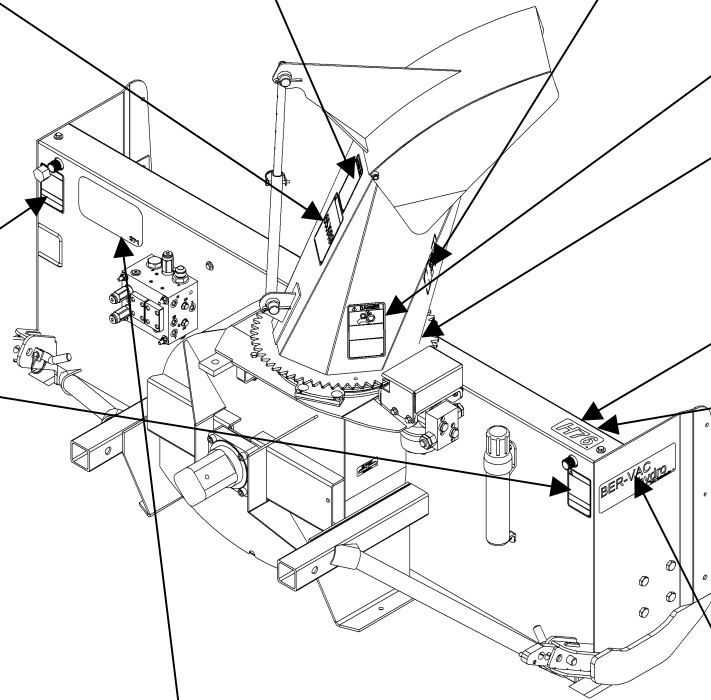

DANGER

2500608



2500312



2500632

WARNING - ATTENTION

• TO AVOID SERIOUS PERSONAL INJURY, ESCAPING HYDRAULIC FLUID UNDER PRESSURE CAN PENETRATE THE SKIN CAUSING SERIOUS INJURY.

• DO NOT USE YOUR HANDS TO CHECK FOR LEAKS. USE A PIECE OF CARDBOARD OR PAPER TO SEARCH FOR LEAKS.

• STOP ENGINE AND RELIEVE PRESSURE BEFORE CONNECTING OR DISCONNECTING LINES.

• TIGHTEN ALL CONNECTIONS BEFORE STARTING ENGINE OR PRESSURIZING LINES.

• IF ANY FLUID IS INJECTED INTO THE SKIN, OBTAIN MEDICAL ATTENTION IMMEDIATELY OR GANGRENE MAY RESULT.

UN LIQUIDE HYDRAULIQUE / DIESEL QUI S'ÉCHAPPE SOUS PRESSION PEUT PÉNÉTRER LA PEAU ET CAUSER DES BLESSURES SÉRIEUSES.

NE PAS UTILISER LES MAINS POUR CHERCHER UNE FUITE. UTILISER UN MORCEAU DE PAPIER OU DE CARTON.

ARRÊTER LE MOTEUR ET ÉVACUER LA PRESSIION AVANT DE DÉCONNECTER LES LIGNES.

SERRER TOUTES LES CONNEXIONS AVANT DE DEMARRER LE MOTEUR OU DE REMETTRE LA PRESSIION SUR LES LIGNES.

SI UN LIQUIDE EST INJECTÉ DANS LA PEAU, OBTENIR IMMÉDIATEMENT UNE ATTENTION MÉDICALE. UNE GANGRÈNE PEUT RÉSULTER.

2500315



2500308

OPERATION PARAMETERS

OPERATION PARAMETERS

It is important to verify the hydraulic system parameters of the machine on which will be used the hydraulic snowblower.

1. You must check the maximum pressure of the hydraulic system of the machine as followed:
 - Let the machine run to bring the hydraulic oil to its normal operation temperature. Shut off the machine.
 - **Figure A:** Install a proper pressure gage on the pressure side of the hydraulic remote of the machine.
 - Start the machine, run the engine at high speed and activate the hydraulic system. Read the maximum pressure indicated on the pressure gage.
 - Repeat the previous steps, but this time with the pressure gage installed on the return line. Read the maximum pressure indicated on the pressure gage.
2. The remote hydraulic pressure of the machine must be between 2100 psi and 3300 psi.
 - If it's less than 2100 psi, the snowblower performance will be poor.
 - If it's over 3300 psi, the hydraulic components of the snowblower will be damaged seriously.

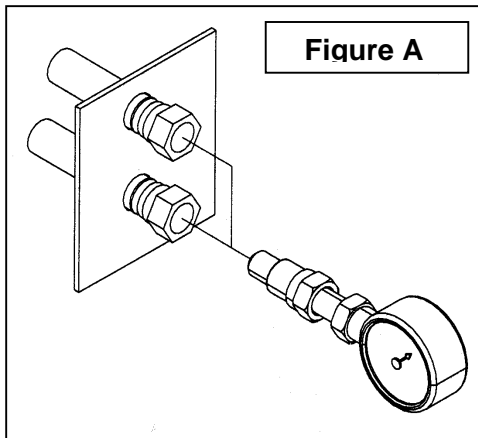

3. The hydraulic return line backpressure of the machine must be lower than 500 psi.

If the return line backpressure is higher than 500 psi, you must install a draining circuit for the hydraulic motors directly to the oil reservoir of the machine. Proceed as follow:

- **Figure B:** Disconnect the two 1/4" hoses (item 1) located on the right side of the hydraulic manifold. Unscrew the two 7/16" ORB male adaptors (item 2) and replace them by two 7/16" ORB male plugs #2600048 (item 2).
- **Figure B:** With a 7/16" JIC male "T" #665562 (item 3), join the two 1/4" hoses. Then on the remaining junction, connect a 1/4" hose (item 4) and direct it to the hydraulic reservoir of the machine.

IMPORTANT: Always check if it's allowed by the machine manufacturer to redirect some oil to the hydraulic reservoir. The amount of oil redirected in maximum operation conditions varies from 2 to 3 GPM.

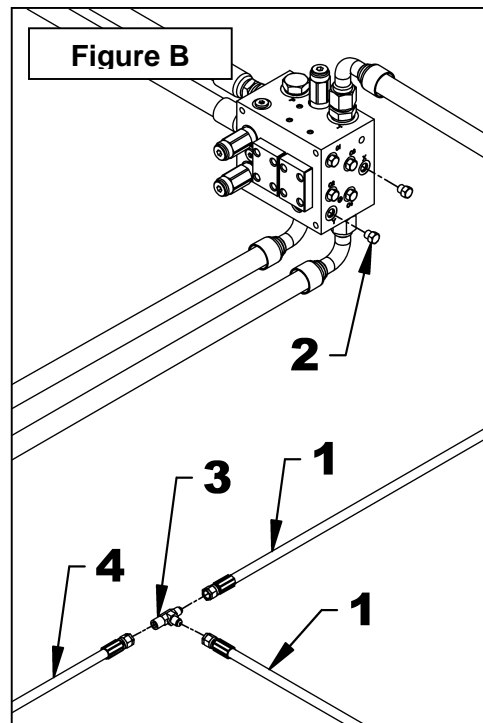

OPERATION PARAMETERS

4. You must check the maximum hydraulic flow of the machine. Proceed as follows:

- Let the machine run to bring the hydraulic oil to its normal operating temperature. Shut off the machine.
- **Figure C:** Install a proper flowmeter on the machine's hydraulic remotes.
- Start the machine, run the engine at high speed and activate the hydraulic system. Read the maximum capacity indicated on the flowmeter.

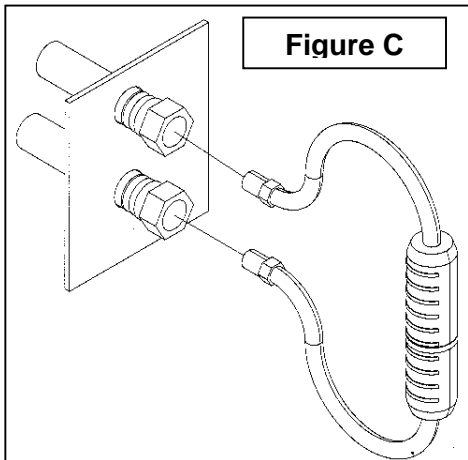

5. The hydraulic flow must be in the range corresponding to the snowblower model to be installed (see Table).

H64A	from 12 to 20 GPM
H76A	from 18 to 25 GPM
H84A	from 18 to 25 GPM

- If the flow is under the minimum, the throwing distance and the snowblower performances will be reduced.
 - If the hydraulic flow is over the maximum allowed for the snowblower, the hydraulic system of the machine may overheat and cause damages to the machine as well as the snowblower
6. When all these parameters are verified and are within the snowblower requirements, you may proceed with the installation of the snowblower on the machine.

ASSEMBLY

SNOWBLOWER ASSEMBLY

The snowblower is pre-assembled at the factory, however snowblower kits must be assembled. Use the present manual and lay out all parts for assembly. Separate bolts and nuts into various sizes. After assembly, torque all the bolts according to the "Torque Specification Table" enclosed at the end of the manual.

Hydraulic Hoses Installation

(Figure 1)

NOTE: The adapters and the supply hoses are not included and need to be custom made for the machine.

1. Remove the cap (item 1) located on top of the snowblower's manifold.
2. Replace the plug (item 2) on top of the hydraulic block by an adaptor 1 1/16" JIC mâle x 1 1/16" ORB.
3. Install the hoses. To do so, use two 3/4" @ 3500psi operating pressure hoses long enough to compensate for the extra length required by the movement of the tractor's articulations with at one end a 1 1/16" JIC swivel female 90° bent at 90° fitting that must be installed on snowblower, and the other end fitted according to the tractor's hydraulic ports.

NOTE: For the H64A, use a straight fitting for the oil port.

IMPORTANT: The snow blower's oil feed is done by the hose on top of the snowblower hydraulic block (item 2) and the return is done by the radiator (item 1).

4. Connect the tractor to the snowblower by passing the hoses through the ring on top the hitch.



WARNING: To avoid serious personal injury. Escaping hydraulic/ diesel fluid under pressure can penetrate the skin causing serious injury.

- Do not use your hands to check for leaks. Use a piece of cardboard or paper to search for leaks.

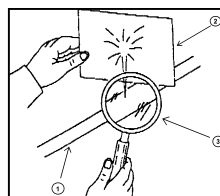
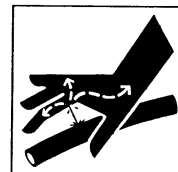

- (1) Hydraulic hose
- (2) Cardboard
- (3) Magnifying glass

- Stop engine and relieve pressure before connecting or disconnecting lines.
- Tighten all connections before starting engine or pressurizing lines.

If any fluid is injected into the skin, obtain medical attention immediately or gangrene may result.

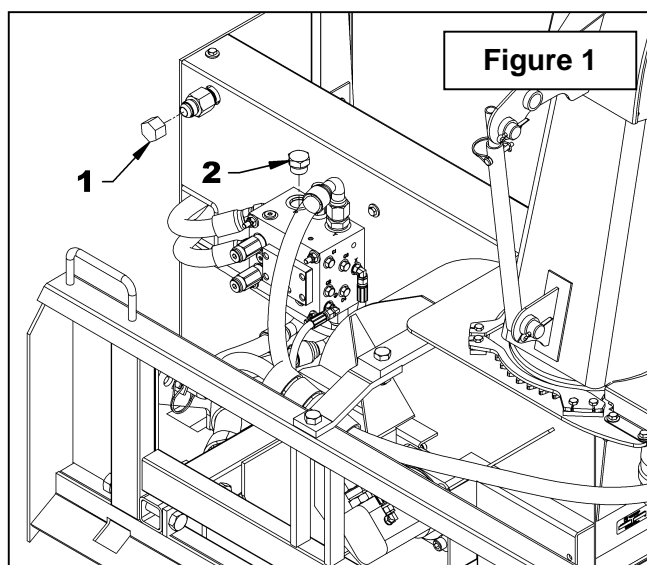

ASSEMBLY

Chute Installation for H64A

(Figures 2 to 5)

1. **Figure 2:** Remove the eight 5/16" NC serrated flange nuts (item 1), the eight 5/16" NC x 1 1/4" lg. bolts (item 2) and the three retaining plates (items 3-4).

2. **Figure 2:** Remove the three 5/16" NC x 3/4" serrated flange bolts (item 5), the three 5/16" serrated flange nuts (item 6) and unscrew slightly the four bolts of the hydraulic motor (item 7).

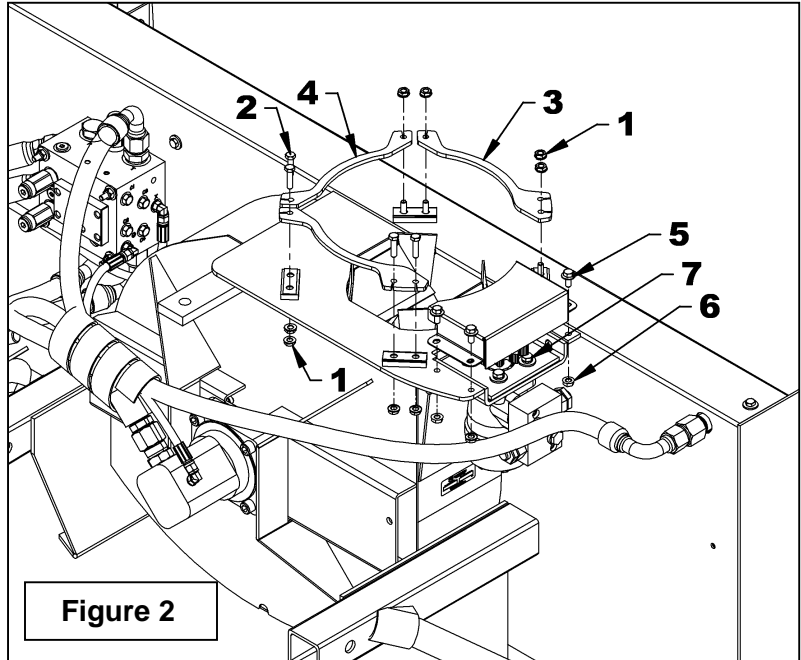

3. **Figure 3:** Install the chute (item 1) with the rotation bushing (item 6) on the snowblower as illustrated and secure with the three retaining plates (items 2-3), the four 5/16" NC x 1 1/4" lg. carriage bolts upside down (front chute), the four 5/16" NC x 1 1/4" lg. hex bolts (item 4) head up (behind chute) and the eight serrated flange nuts (item 5).

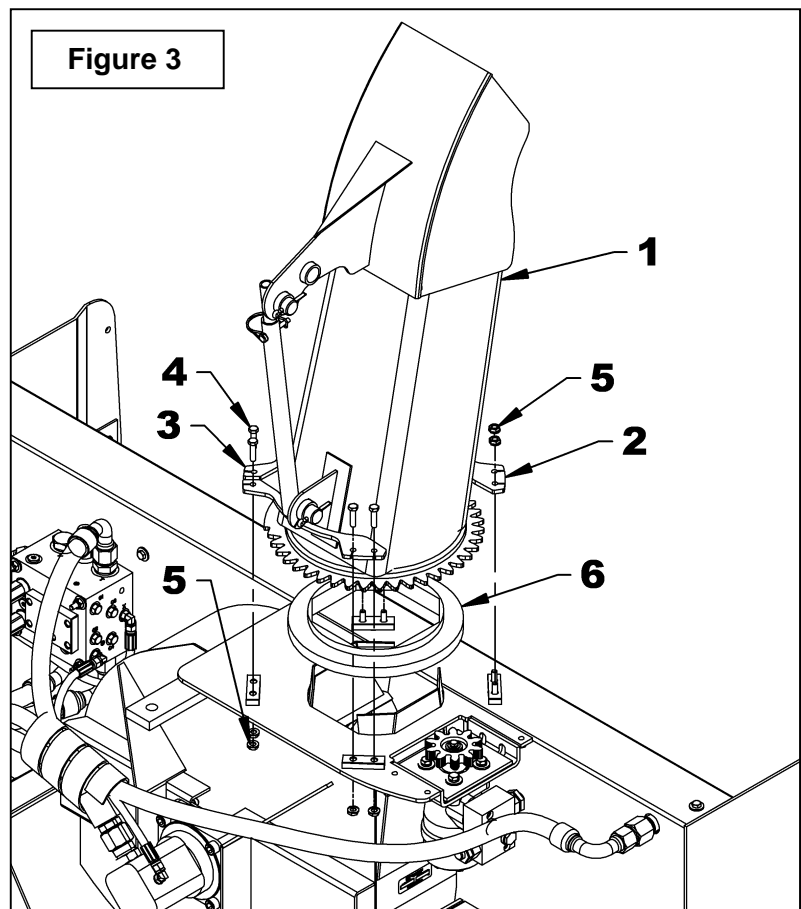

ASSEMBLY

4. **Figure 4:** If the distance between the motor gear and the chute gear is higher than $1/16$ " , adjust the motor gear position by unscrewing the two nuts and screwing in the two adjustment bolts (item 1) until the distance is between $1/32$ " and $1/16$ ". Tighten firmly the two nuts (item 2).

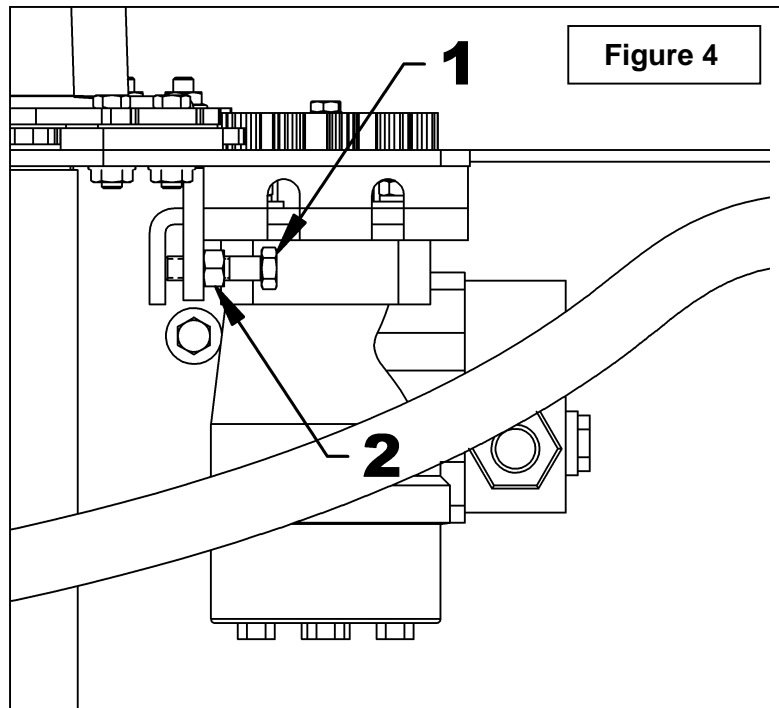

5. **Figure 5:** Tighten the four bolts (item 1) of the hydraulic motor and reinstall the guard (item 2) with the three $5/16$ " NC x $3/4$ " serrated flange bolts and three $5/16$ " serrated flange nuts (items 3-4).

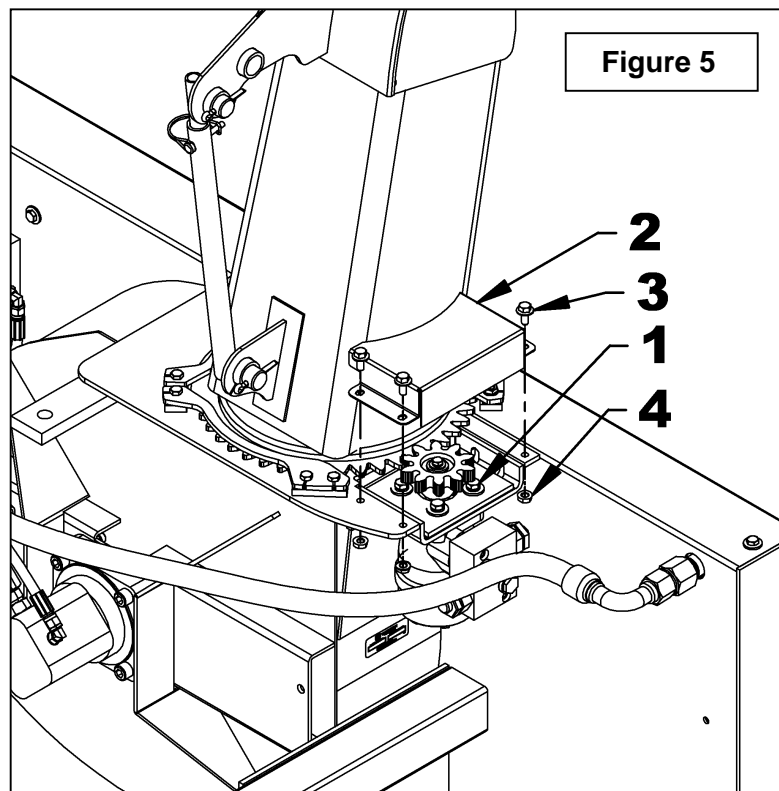

ASSEMBLY

Chute Installation for H76A & H84A (Figures 6 to 9)

1. **Figure 6:** Remove the six 1/2" NC serrated flange nuts (item 1), the six 1/2" NC x 1 3/4" lg. carriage bolt (item 2) and the two retaining plates (items 3-4).

2. **Figure 6:** Remove the four 5/16" NC x 3/4" serrated flange bolts (item 5), the four 5/16" serrated flange nuts (item 6) and unscrew slightly the four bolts of the hydraulic motor (item 7).

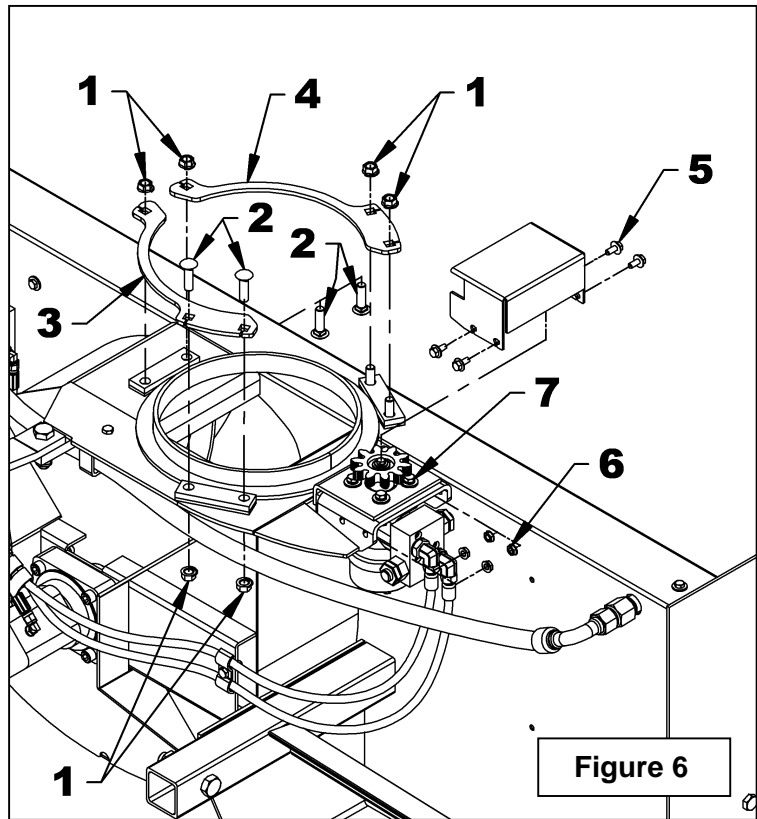

3. **Figure 7:** Install the chute (item 1) on the snowblower as illustrated and secure with the two retaining plates (items 2-3), the four 1/2" NC x 1 3/4" lg. carriage bolts (item 4 - two head up) and the six serrated flange nuts (item 5).

NOTE: The chute must be placed exactly in the shown position to facilitate the insertion of the two bolts (item 4) from above.

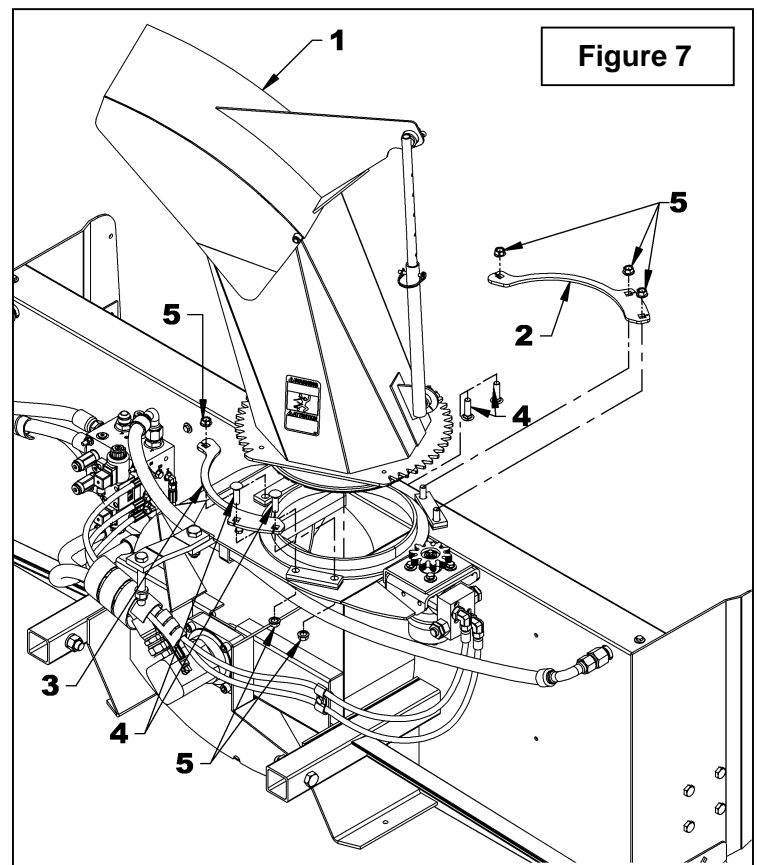

ASSEMBLY

- Figure 8:** If the distance between the motor gear and the chute gear is higher than $1/16"$, adjust the motor gear position by unscrewing the two nuts and screwing in the two adjustment bolts (item 1) until the distance is between $1/32"$ and $1/16"$. Tighten firmly the two nuts (item 2).

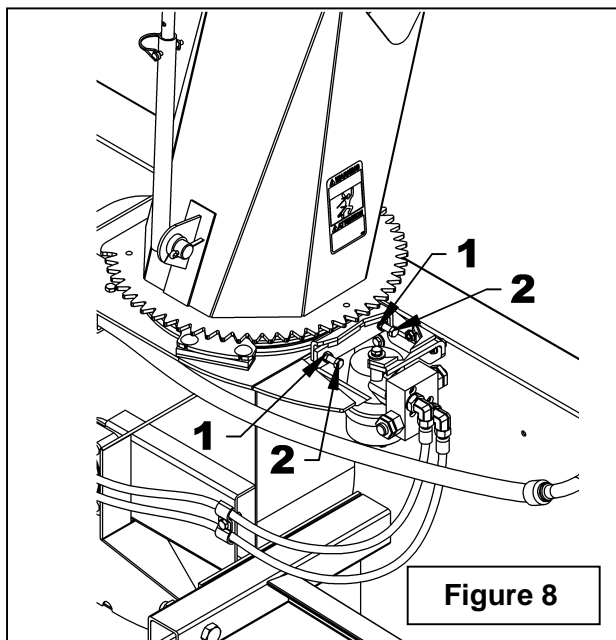

- Figure 9:** Tighten the four bolts (item 1) of the hydraulic motor and reinstall the guard (item 2) with the three $5/16"$ NC x $3/4"$ serrated flange bolts and three $5/16"$ serrated flange nuts (items 3-4).

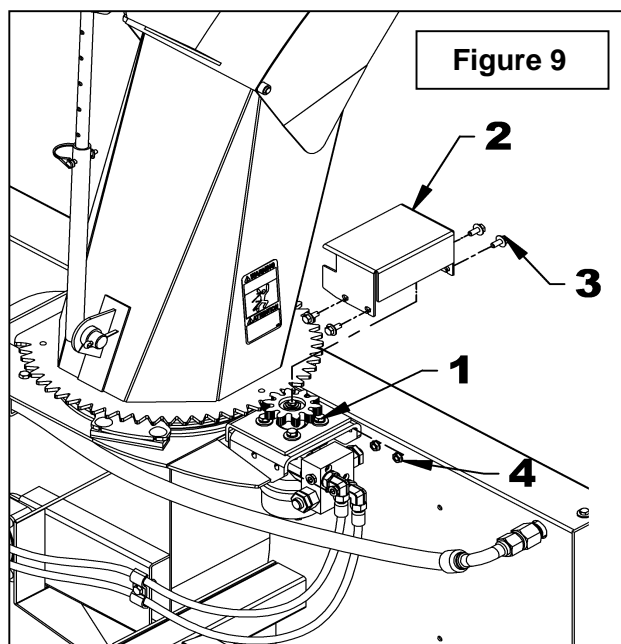

Chute Rotation

NOTE: The elbows and the hoses are not included and need to be custom made for the machine.

- Install two 90° $7/8"$ ORB male X $9/16"$ JIC male elbows on the hydraulic motor of the chute rotation.
- Install two $1/4"$ @ 3500psi hoses long enough to compensate for the extra length required by the movement of the tractor's articulations, one end to the motor chute rotation and the other to the tractor by passing the hoses through the hose support of the universal hitch.

IMPORTANT: Make sure hoses are attached without getting in contact with any moving parts.

NOTE: If the tractor has no oil port, use the 8183A hydraulic valve kit (not provided).

ASSEMBLY

Installation of Universal Hitch - 8153

(Figure 10)

1. Attach the hitch arms (item 2) to the universal hitch (item 1) using two 3/4" NC x 6" hex. bolts (item 4), 3/4" lockwashers (item 9) and 3/4" hex. nuts (item 11).
2. Insert the universal hitch (item 1) in the snowblower tubes and secure with 3/4" NC x 3 1/2" hex. bolts (item 5), 3/4" lockwashers (item 9) and 3/4" NC hex. nuts (item 11).
3. Place longest end of upper bracket (item 3) under the snowblower bracket. Secure using a 5/8" NC x 2" hex. bolt (item 6) on the snowblower and a 5/8" NC x 1 1/2" hex. bolt (item 7) on the hitch. Secure with a 5/8" lockwasher (item 8) and a 5/8" hex nut (item 10).

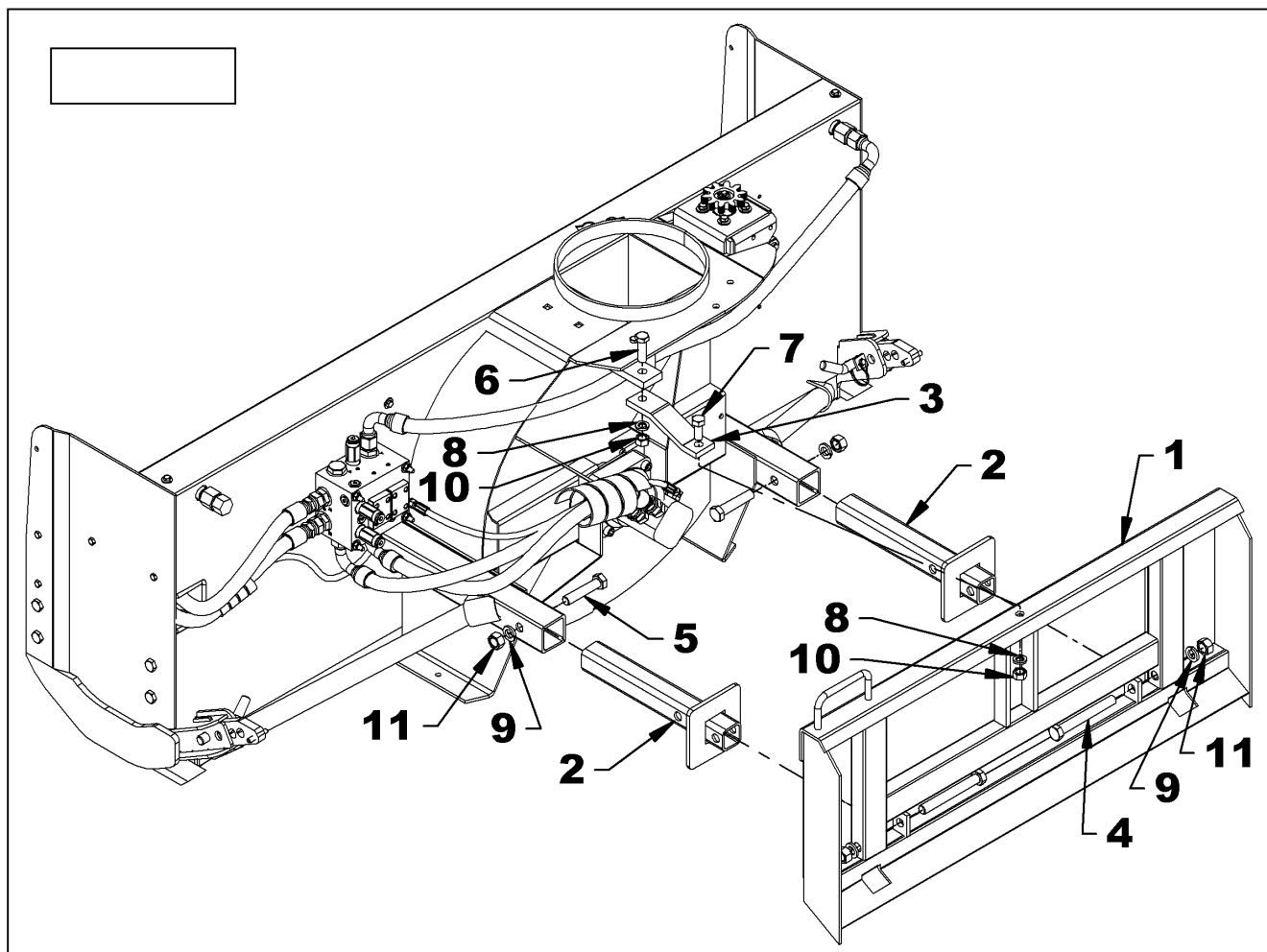

ASSEMBLY

Installation of the hydraulic rotation valve kit- 8183A

(Figures 11 to 17)

1. **Figure 11:** Remove the two plugs from the "C1" and "C2" hydraulic block ports and replace them by two 90° 7/16" ORB M. X 7/16 JIC M. elbows (items 1-2) in the position illustrated.
2. **Figure 13:** Install the 90° 9/16JIC M. X 7/8 ORBM elbows (item 1) in the motor ports by positioning the elbows down.
3. **Figure 13:** Connect hoses (items 2-3) to the hydraulic block 90° elbows and to the hydraulic motor as illustrated.
4. **Figure 13:** Attach hoses with the hose clamp (item 4), the 3/8" x 1 1/4" lg bolt (item 5) and the nylon insert locknut (item 6).
5. **Figure 12:** Remove the 10-24 X 7/8" cylindric allen set screws and the right plate of the hydraulic block. Make sure to remove the o-rings glued to the hydraulic block and clean well the four holes before valve installation. Attach the electro-hydraulic valve (item 1) to the block with the four cylindric allen set screws (item 2) provided with the valve, making sure the o-rings are well placed on the valve.

IMPORTANT: Make sure the electric valve is installed in the right direction. It must have the "T" indication toward the overpressure valves (fig. 12, item 3).

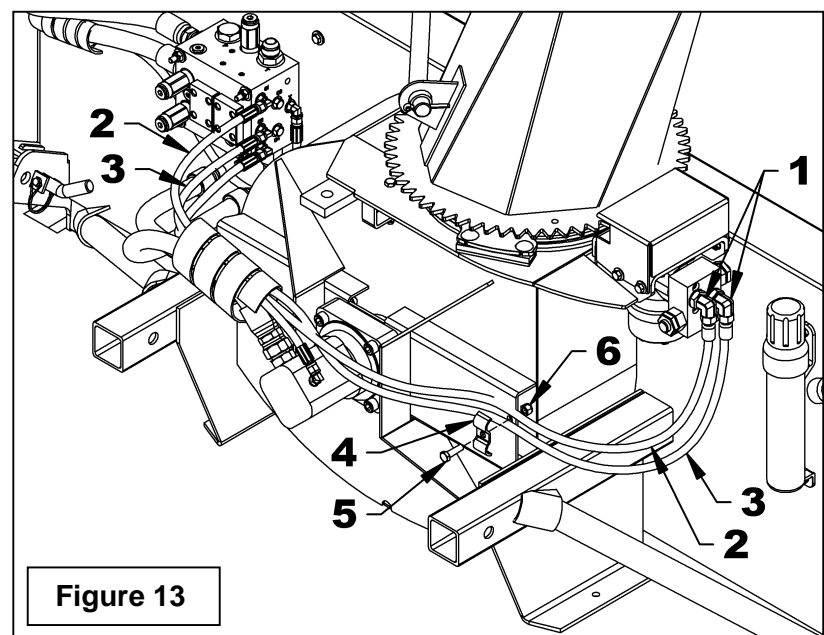
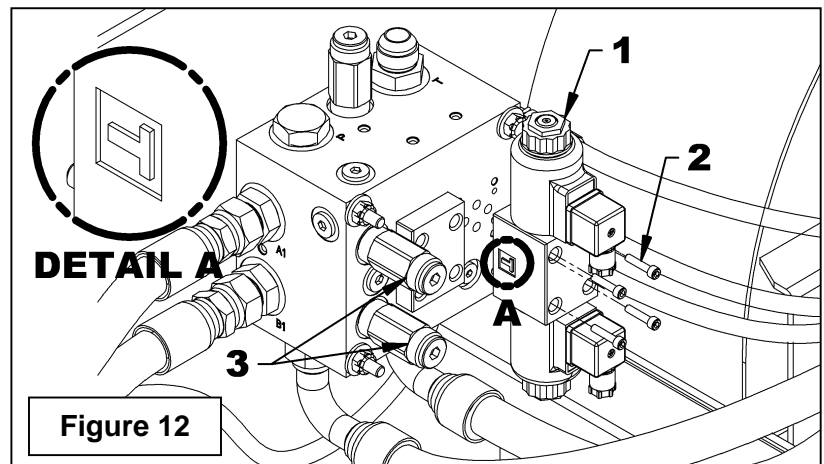
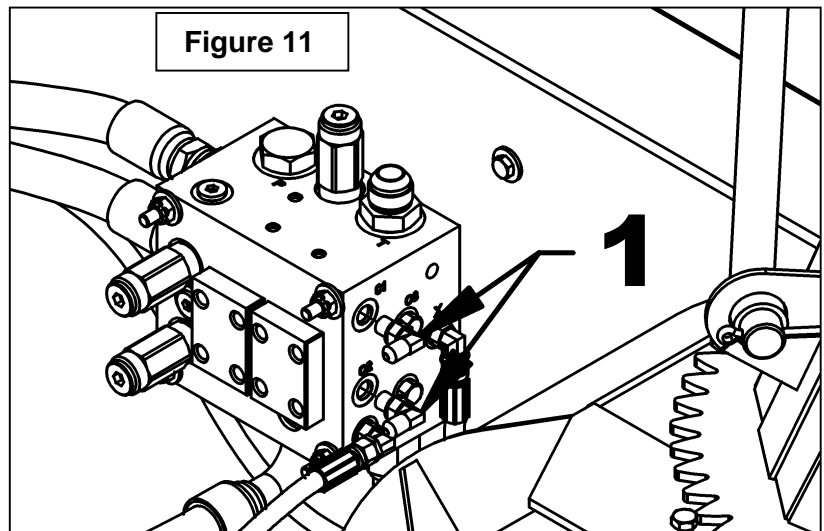

ASSEMBLY

6. **Figure 14:** Remove the DIN connectors (item 1) by removing the two screws (item 2).

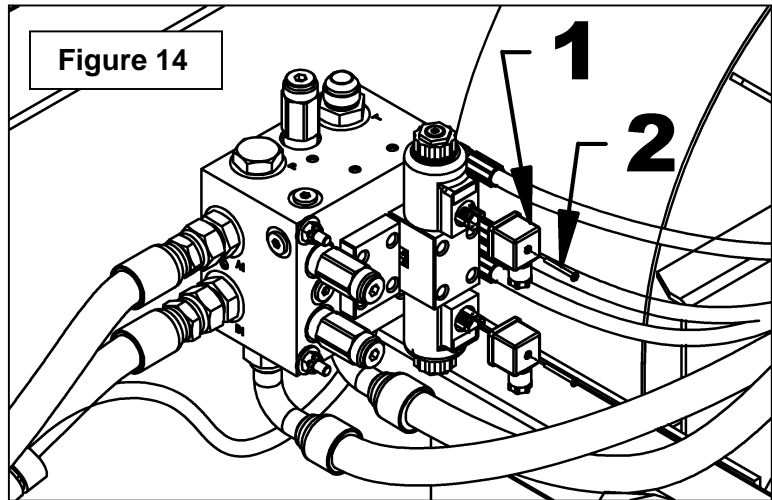

7. **Figures 15a-15b:** Disassemble the DIN connectors (fig. 15b, item 1) and connect the 160" harness wires as illustrated on Figure 15a. When connecting the wires, make sure to position the terminal board in the proper direction in the block so the wires point down once installed on the valve.

8. **Figure 14:** Reinstall the DIN connectors (items 3-4) on the valve making sure the white wire is in the upper connector and the blue wire is in the lower one and that the wires point down.

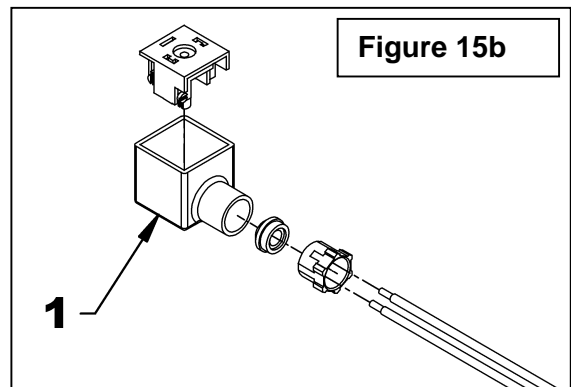

9. Install the switch in one of the holes of the switch box and install the switch box on the machine where it can be easily accessed when operating the snowblower with the hardware provided. If bolts are not long enough, use longer ones by making sure to not touch with the switches.

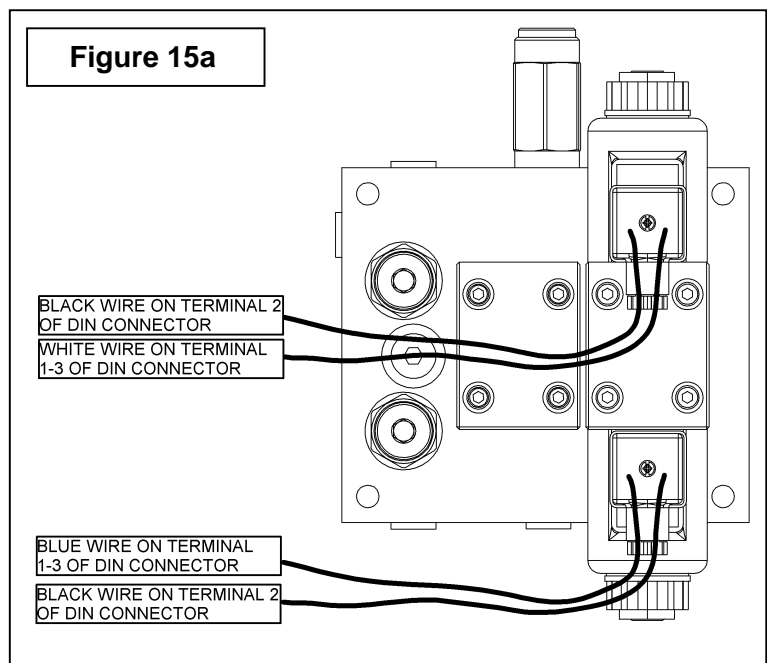

ASSEMBLY

10. Take the 160" harness to the same place than the hydraulic hoses to the front of the tractor, near the tractor starter. Attach the harness with the nylon tie wrap and insert with the hoses in the 4" hoses protector and then in the 360" loom. If it is a deflector reinstallation, connect the male connector of the 160" harness to the tractor female connector.

11. **Figure 16** : Install the male terminals on the stripped end of the white wires and the black ground wire. Connect those terminals to the three cavity female connector making sure to install the black wire in the "A" cavity.

12. Attach the black wire to an appropriate ground on the tractor frame.

13. Connect the fuse wire to the tractor contact switch wire with the connector tap.

14. Connect the male connector to the female connector.

15. **Figure 17**: Connect the fuse wire to the 1 blade (item 1) - in the center, one white wire to the item 2 blade and the other to the item 3 blade of the switch.

NOTE: If the deflector movement is not corresponding to the switch illustration, reverse the white wires.

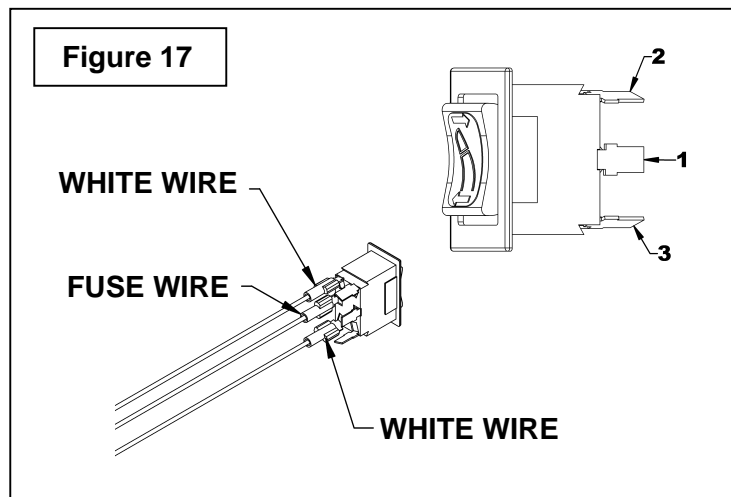
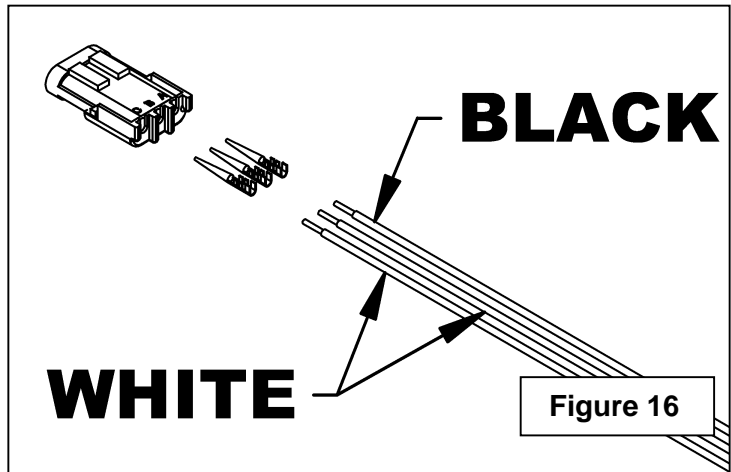

ASSEMBLY

Hydraulic Deflector 8184A

- H64A: 2" x 6" Cylinder Kit 8155

- H76A & H84A: 2" x 8" Cylinder Kit 8249

(Figures 18 à 31)

1. **Figure 19:** Remove the retaining ring (items 1-4) of each cylinder pin (items 2-3) and remove the pins. Place the hydraulic outputs in the position illustrated on figure 22 and attach the cylinder base (item 5) to the chute base and the sliding section to the deflector with the pins and retaining rings (items 1-2-3-4).
2. **Figure 19:** Remove the two plugs (items 1-2) from "C3" and "C4" hydraulic block ports.
3. **Figure 20:** Install the 90° 7/16" ORB M. X 7/16 JIC M. elbows (items 1-2) in the "C3" and "C4" hydraulic block ports by positioning the elbows in the illustrated direction.
4. **Figure 21:** Install the 90° 3/8 NPT M. X 1/4 NPT PIV. F. elbows (items 1-2) in the cylinder ports by positioning the elbows in the illustrated direction. Add thread sealant on the elbow male section.

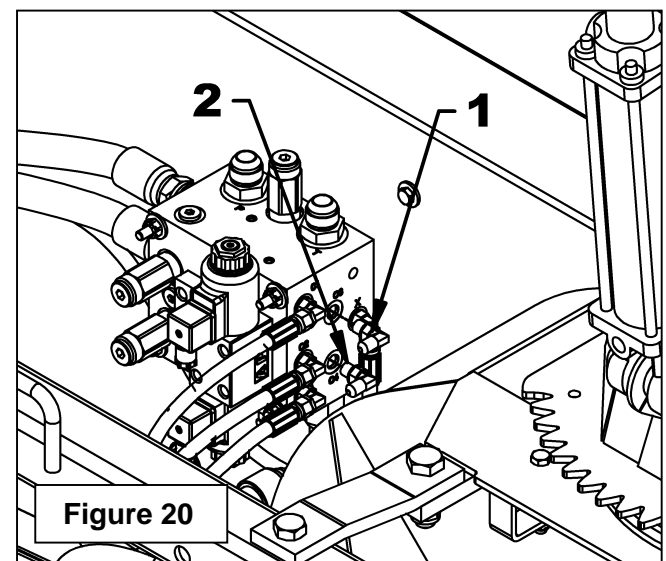
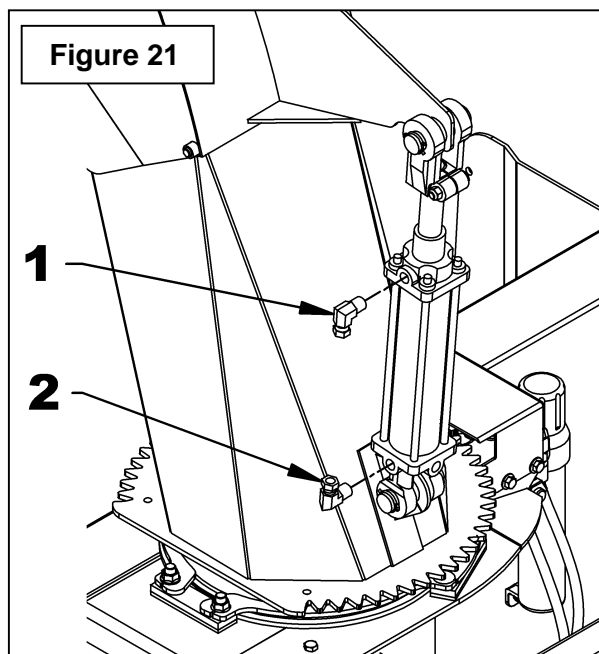
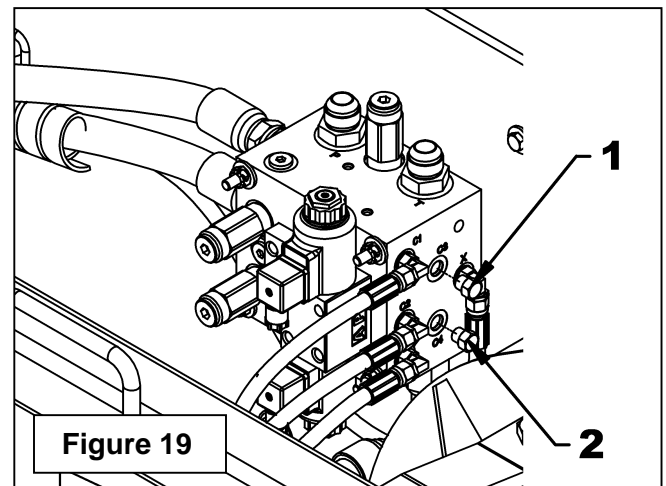
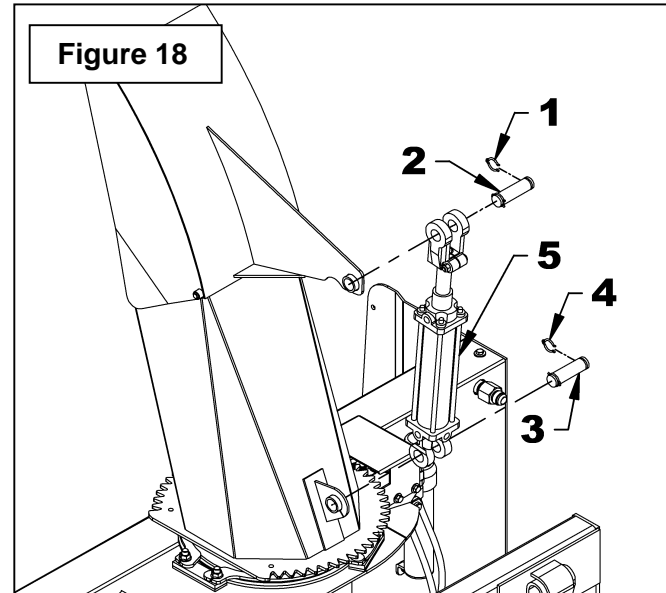

ASSEMBLY

5. **Figure 22:** Attach the hose support (item 4) on the universal hitch with a 5/8" NC bolt, a lockwasher and nut (items 1-2-3, not provided).

6. **Figure 23:** Apply thread sealant on each hose male part (items 1-2) and screw in the cylinder 90° elbows (items 3-4).

7. **Figure 24:** Connect each hose female end (items 1-2) to hydraulic block 90° elbows (items 3-4) making sure to connect cylinder rod hose to the "C4" hydraulic block port.

8. **Figure 25:** Attach hoses to the hose support (item 1) with the clamp (item 2), the 3/8" x 1 1/4" lg bolt (item 3) and nylon insert locknut (item 4) by letting long enough hose to allow a complete rotation of the chute. Install the hose protector (item 5) as illustrated.

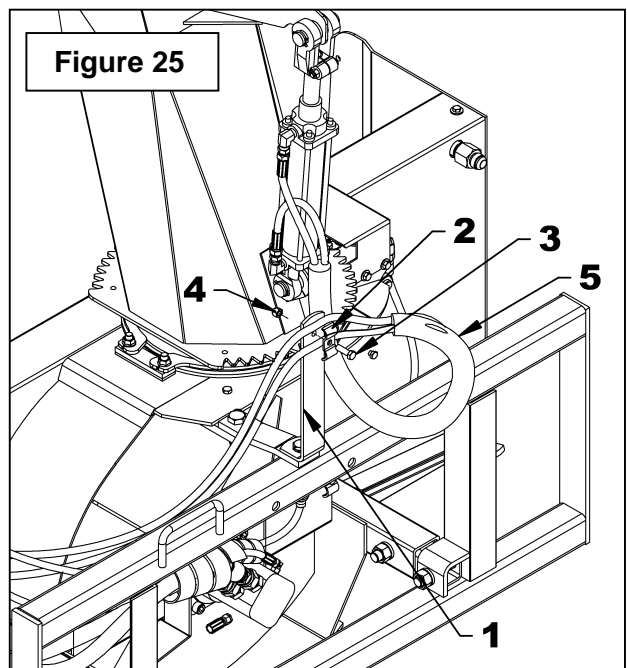
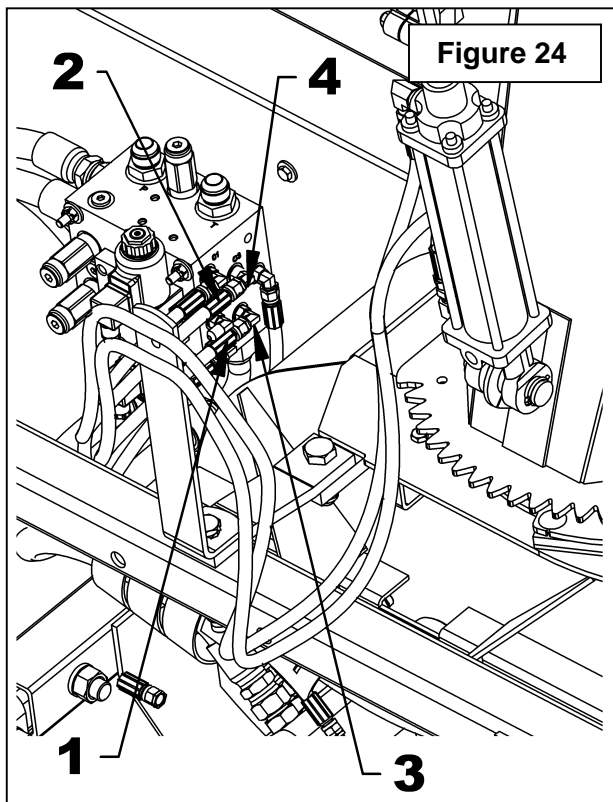
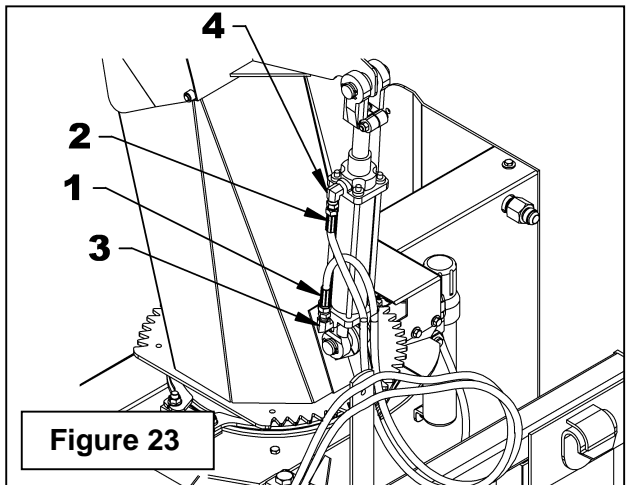
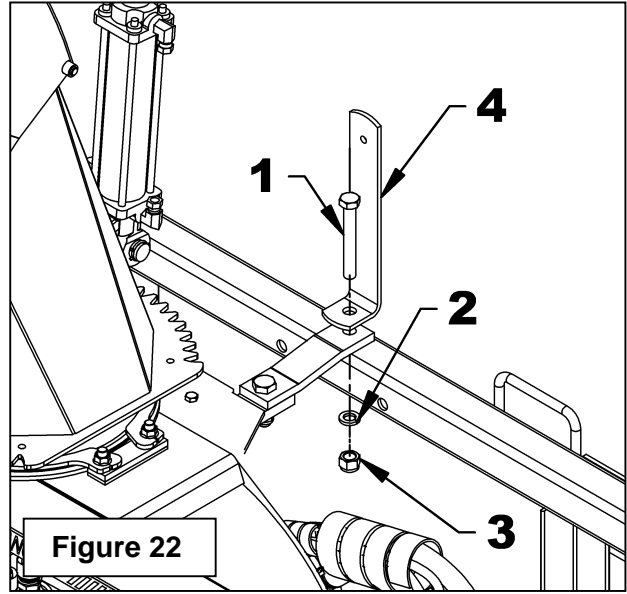

ASSEMBLY

9. **Figure 26:** Remove the 10-24 X 7/8" cylindric allen set screws (item 1) and remove the plate (item 2). Make sure to remove the o-rings glued to the hydraulic block and clean well the four holes before valve installation.

10. **Figure 27:** Attach the electro-hydraulic valve (item 1) to the block with the four cylindric allen set screws (item 2) provided with the valve, making sure the o-rings are well placed on the valve.

IMPORTANT: Make sure the electric valve is installed in the right direction. It must be installed in the same direction that the one already installed with the "T" indication toward the overpressure valves (fig. 27 item 3).

11. **Figure 28:** Remove the DIN connectors (item 1) by removing the two screws (item 2).

12. **Figures 29a-29b:** Disassemble the DIN connectors (Fig. 29b, item 1) and connect the 160" harness wires as illustrated on Figure 29a. Reinstall the DIN connectors (items 3-4) on the valve making sure the white wire is in the upper connector and the blue wire is in the lower one and that the wires point down.

13. **Figure 28:** Reinstall the DIN connectors (items 3-4) on the valve making sure the white wire is in the upper connector and the blue wire is in the lower one and that the wires point down.

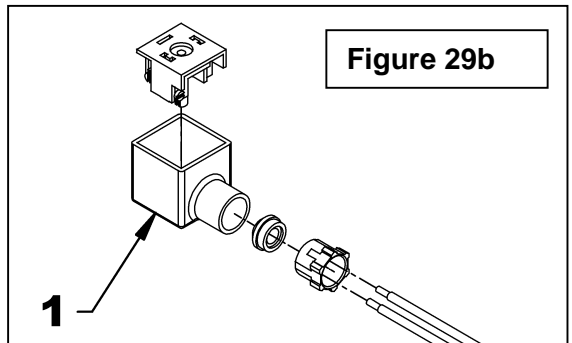
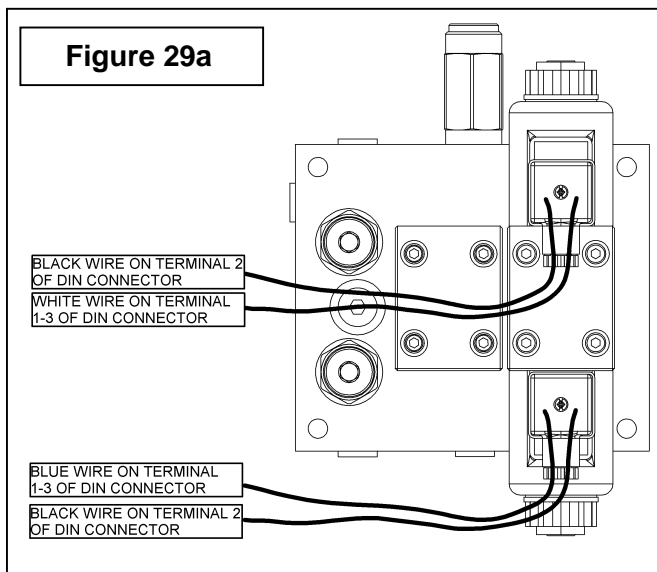
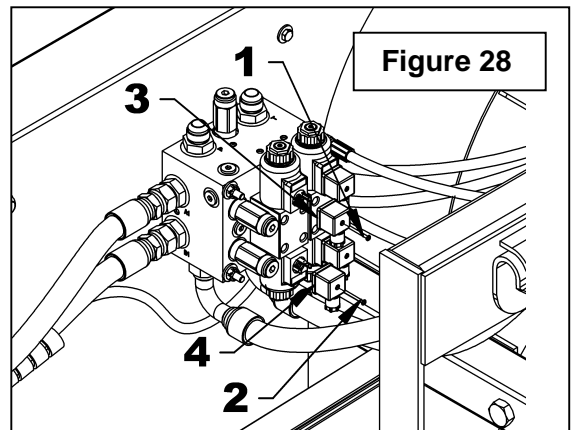
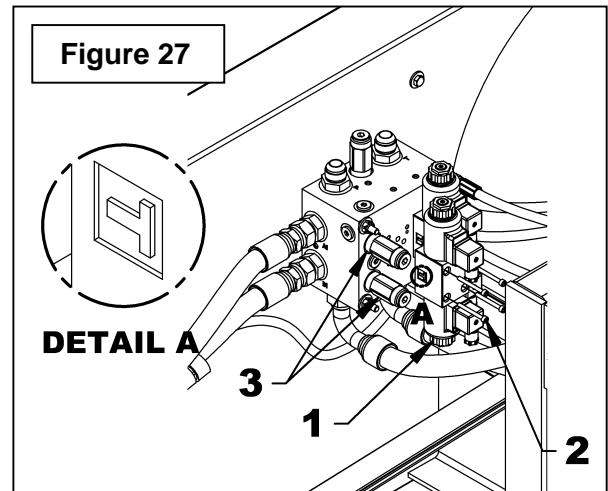
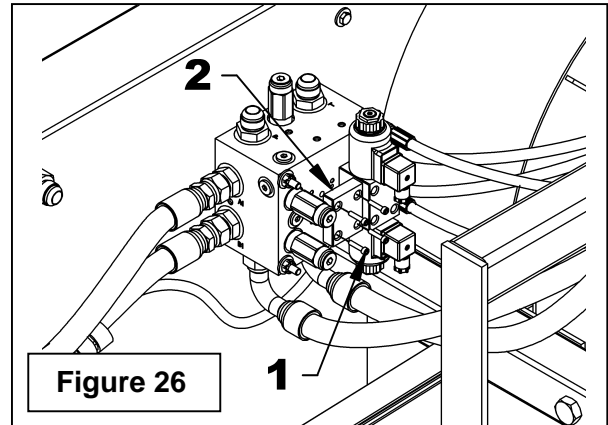

ASSEMBLY

14. Install the switch in one of the holes of the switch box and install the switch box on the machine where it can be easily accessed when operating the snowblower with the hardware provided. If bolts are not long enough, use longer ones by making sure to not touch with the switches.

15. Take the 160" harness to the same place than the hydraulic hoses to the front of the tractor, near the tractor starter. Attach the harness with the nylon tie wrap and insert with the hoses in the 4" hoses protector and then in the 360" loom. If it is a deflector reinstallation, connect the male connector of the 160" harness to the tractor female connector.

16. **Figure 30** : Install the male terminals on the stripped end of the white wires and the black ground wire. Connect those terminals to the three cavity female connector making sure to install the black wire in the "A" cavity.

17. Attach the black wire to an appropriate ground on the tractor frame.

18. Connect the fuse wire to the tractor contact switch wire with the connector tap.

19. Connect the male connector to the female connector.

20. **Figure 31**: Connect the fuse wire to the 1 blade (item 1) - in the center, one white wire to the item 2 blade and the other to the item 3 blade of the switch.

NOTE: If the deflector movement is not corresponding to the switch illustration, reverse the white wires.

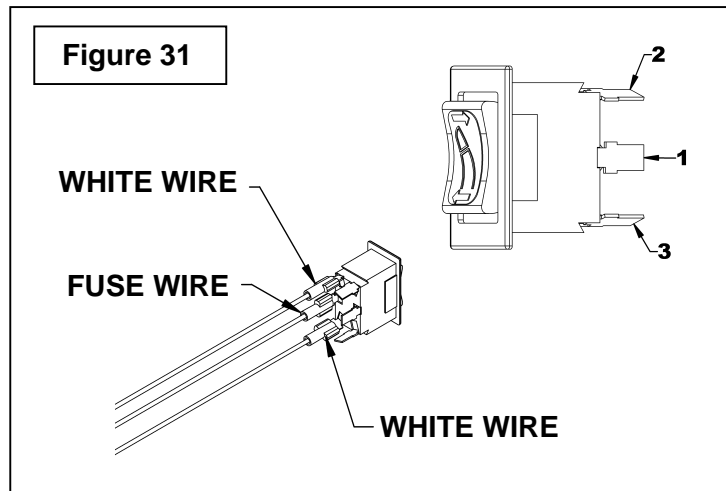
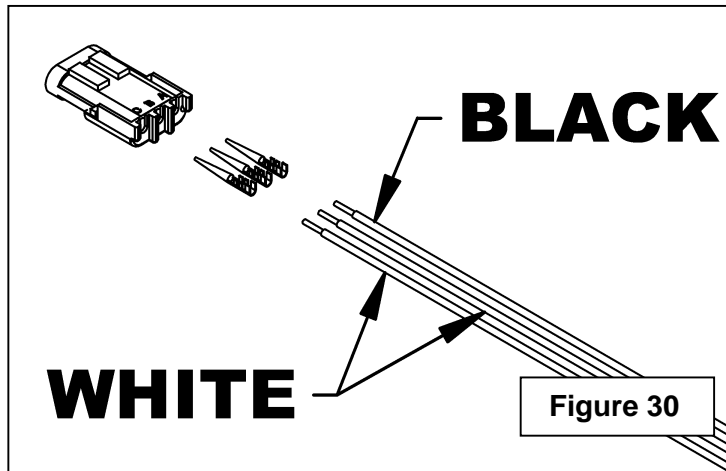

ASSEMBLY

Electric Deflector for H64 - 8154 **(Figure 32 & Electrical Diagram)**

1. Shut off the engine and remove the ignition key.
 2. Install the longer clevis (item 6) on the actuator base (item 1) and the shorter clevis on the other end (item 7) and attach using a 1/2" NC x 2 1/2" bolt (item 16) and a 1/2" NC nylon insert locknut (item 17).
 3. Install a 3/16" x 1 3/4" spring pin (item 13) on each 1" pin (item 8).
 4. Install the actuator on the chute (see Figure 32 for actuator position) using two 1" pins (item 8) and secure with a 4mm x 80mm hairpin (item 14).
- NOTE:** For the H76A and H84A snowblower, install the actuator in the available holes on the chute.
5. Connect the ground wire (item 9, black 72") to terminal "C" on switch (item 3).
 6. Connect fuse wire (item 11, red 72") to terminal "B" on switch (item 3).
 7. Connect actuator wires (item 12, 1 red and 1 black 360") to terminal "A" and "D" on switch (item 3).
 8. If switch box is already installed for the electric rotation, go to step 8. If not, install the switch box (item 2) at a convenient location for easy access when operating the snowblower. Secure using three #10 x 1/2" self-drilling screws (item 15). Leave a hole to install the ground wire. Avoid placing switch box where wires are already installed as they could be damaged.
 9. Unscrew the nut and remove the lockwasher from the switch (item 3) and insert the switch in the switch box (item 2). Tighten the switch with its nut. Place the plastic cap (item 5) over the free hole in the switch box (if necessary) and screw the rubber cap (item 4) on the switch.
 10. Connect the black ground wire eye terminal (item 9) to the fourth #10 x 1/2" screw (item 15), and screw into the free hole of the switch box (item 2).
 11. Connect the fuse wire (item 11) to the tractor ignition switch wire using the tap connector (item 10).
 12. Connect the actuator wires (item 12) to the electric actuator (item 1).
 13. Place a loom (item 18) around all wires to protect them. Secure the loom using tie wraps.

ASSEMBLY

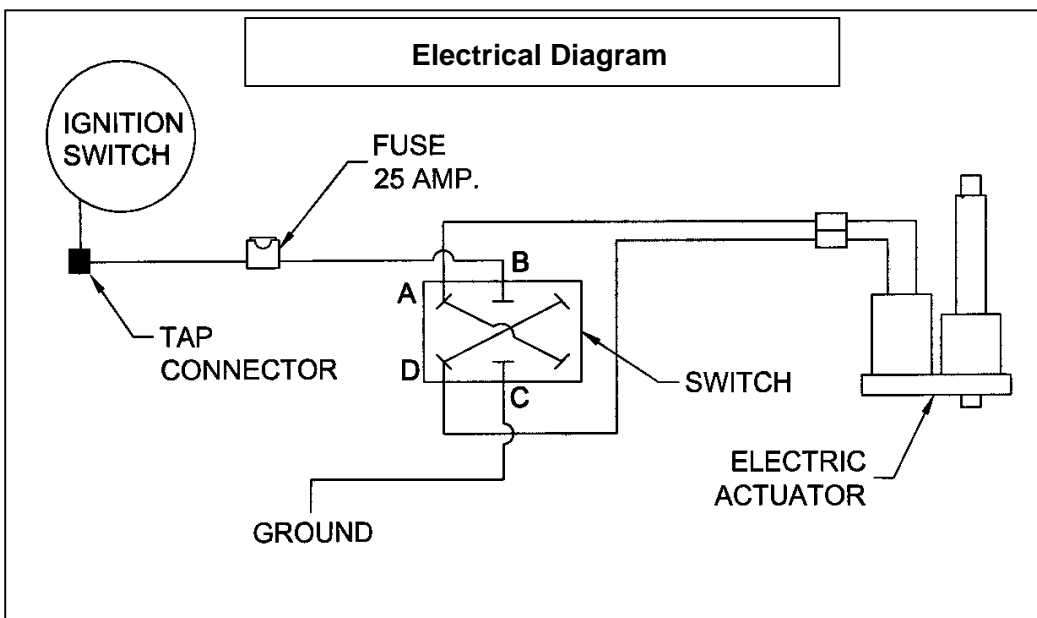
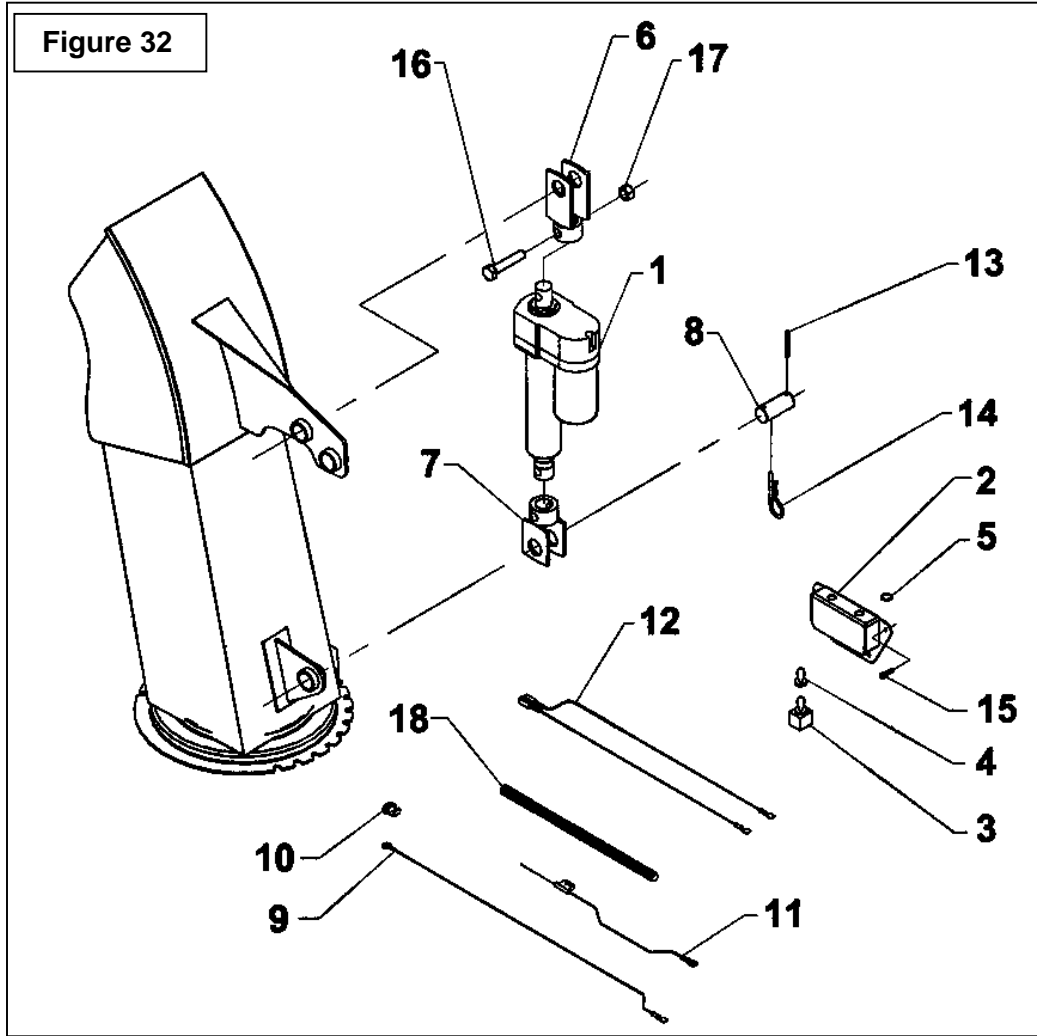

ASSEMBLY

Installation of the Drift Cutters - 8152 (Figure 33)

1. Remove the 1/2" NC x 1 1/4" bolt (item 5) from the motor support (item 17) and the 5/16" NC x 1 1/4" bolt (item 4) from the hose guard (item 16).
2. Position the left drift cutter (item 2) next to the holes in the housing and reinstall the 1/2" NC x 1 1/2" bolt (item 5), 1/2" (9/16" hole) flat washer (item 8), 1/2" lockwasher (item 9) and 1/2" NC nut (item 10) in the lower hole.
3. In the middle hole, reinstall the 5/16" NC x 1 1/4" bolt (item 4), 1/4" (5/16" hole) flat washer (item 11), 5/16" lockwasher (item 12) and 5/16" NC nut (item 13).
4. In the upper hole, insert a 3/8" NC x 1" bolt (item 3), 3/8" lockwasher (item 14) and 3/8" NC nut (item 15).
5. Line up the upper hole of the right drift cutter (item 1) with the upper hole in the housing and secure the cutter using the 3/8" NC x 1" bolt (item 3), 3/8" lockwasher (item 15) and 3/8" NC nut (item 14).
6. Make sure that the right drift cutter is lined up with the housing and drill a 11/32" hole in the housing, using the middle hole of the right drift cutter (item 1) as a template. Insert a 5/16" NC x 1" bolt (item 6), 5/16" lockwasher (item 12) and 5/16" NC nut (item 13).
7. Drill a 17/32" hole in the housing using the lower hole in the right drift cutter (item 1) as the template. Insert a 1/2" NC x 1 1/4" bolt (item 7), 1/2" lockwasher (item 9) and 1/2" NC nut (item 10).

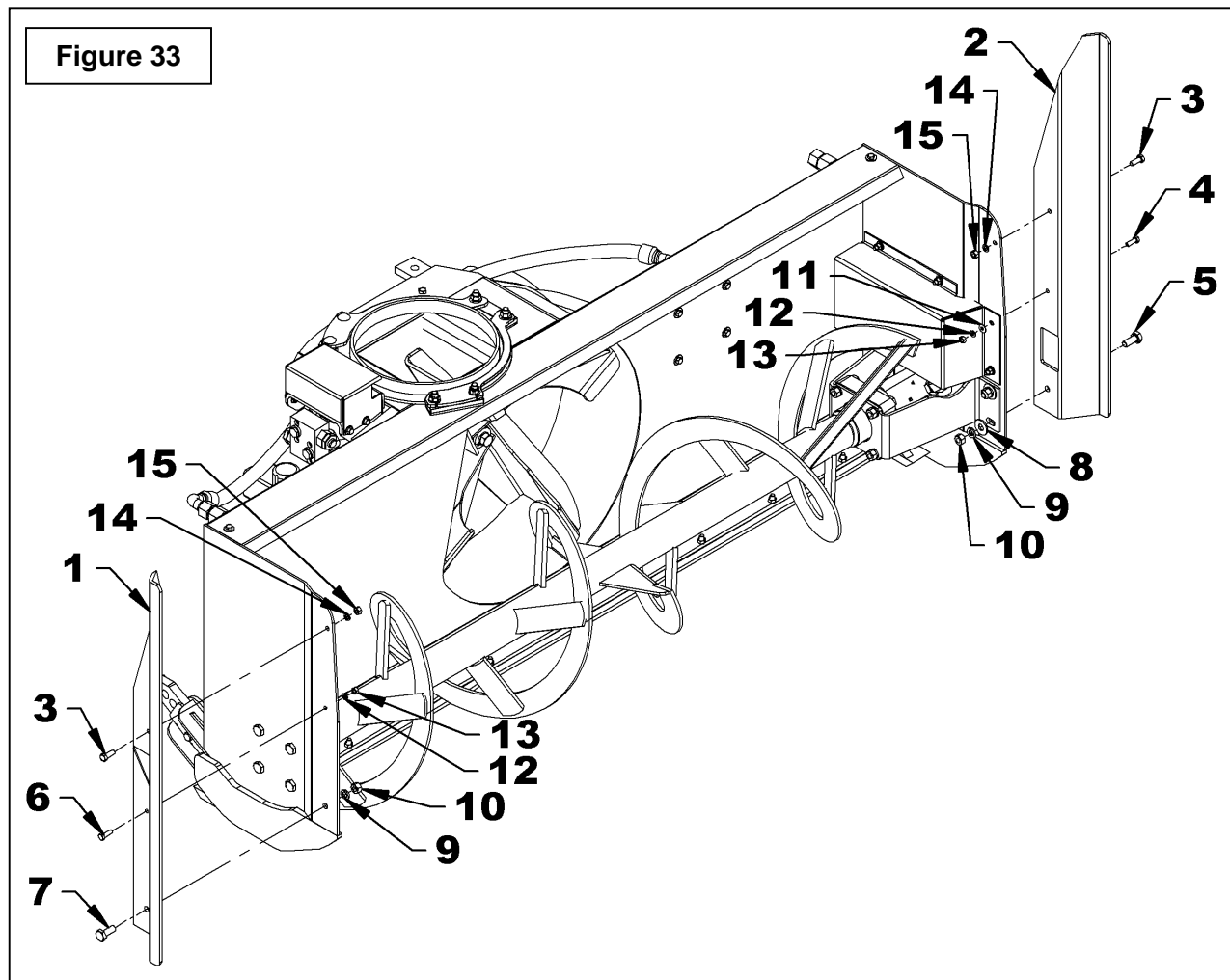

ASSEMBLY

OPTIMUM PERFORMANCES

IMPORTANT: The hydraulic motors of the snowblower must have a breaking in period. If it is not respected, the warranty could be voided. The breaking in period must follow these steps:

- 1- 15-30 minutes of operation without any load and at half speed (tractor RPM around 1250).
- 2- Check for unusual noises coming from the motors. If everything sounds normal, the load and engine speed can be increased.

Optimum snowblower performances are only achieved after 10 to 15 minutes of operation. It is therefore important to make certain that the hydraulic oil reaches a temperature over 40°C (104°F) before evaluating the performances

Snowblower performances are highly sensitive to hydraulic pressure. The higher the pressure (while still remaining below 3000 psi), the higher the snowblower performances will be.

GENERAL PREPARATION

1. Read the operator's manual carefully before using the tractor and snowblower. Be thoroughly familiar with the controls and proper use of the equipment. Know how to stop the unit and disengage the controls quickly.
2. Wear adequate winter outer garments while operating equipment.
3. Make sure the snowblower is clear of snow before engaging the hydraulic system.
4. Make sure the auger and fan operate freely.
5. Adjust the skid shoes so the snowblower runs level.
6. To obtain optimum performances of the snowblower, the oil in the hydraulic system must be warmed up for 10 to 15 minutes.

OPERATING CONTROLS

Manual Deflector Adjustment

Set the angle of the deflector according to the distance the snow must be thrown. To set the deflector angle, remove the round wire lock pin from the adjustment tube, adjust the deflector to the appropriate angle and replace the hairpin.

Hydraulic or Electric Deflector Adjustment

IMPORTANT: The snowblower drive system must be engaged to move the hydraulic deflector.

To adjust the angle of the deflector, move the switch forward or to the left to lower the deflector. Move the switch rearward or to the right, to raise it. If the operation is not as described, reverse the switch wires.

Hydraulic or Electric Rotation Adjustment

IMPORTANT: The snowblower drive system must be engaged to rotate the hydraulic chute.

To turn the chute left (counterclockwise), move the switch forward or to the left to lower the deflector. Move the switch rearward or to the right, to move the chute to the right (clockwise). If the operation is not as described, reverse the switch wires.

OPERATION

Ground Speed

Ground speed will depend on the thickness and density of the snow to be cleared away. Normally, ground speed will range from 4 to 7 MPH for light, dry snow 3 to 6 inches thick, and 1 to 3 MPH for heavy, wet or icy snow. To transport, disengage the hydraulic system and raise the snowblower to full transport height.

Skid Shoes Adjustment

Adjust the snowblower so that the skid shoes run level and according to the surface conditions so that stones are not thrown with the snow. Adjust both skid shoes to the same height to keep the cutting edge level and adjust upwards for smooth surfaces.

Remove skid shoe bolts and adjust according to instructions below:

Clearance between cutting edge and surface

- *Level paved surface:* Adjust 1/16" to 1/8"
- *Uneven or gravel surface:* : Adjust 1/2" and more depending on the gravel size.

IMPORTANT: Avoid overloading the snowblower or driving it in reverse for too long. Driving the snowblower in reverse now and then to dislodge an object blocking the snowblower is acceptable.

IMPORTANT: The fan and auger are driven directly by hydraulic motors. Relief valves have replaced the shear bolts.

When an object blocks the fan or the auger, they stop turning. They start turning again when the object is removed.



DANGER: To avoid serious injuries: Keep clear of rotating parts. Do not put hands or feet under, or into snowblower with engine running.

Park the tractor/snowblower on level ground, place the transmission in neutral, set the parking brake, disengage the equipment drive, lower the equipment to the ground, place all control levers in neutral, shut off the engine, remove the ignition key and allow the rotating parts to stop **BEFORE** unclogging the collector/fan housing or chute, and making any repairs, adjustments or inspections. Use only a 36" long piece of wood to unclog blower.

Not respecting these instructions can result in serious injuries.

OPERATION

SNOW REMOVAL METHODS

When removing snow, do not use the snowblower as a dozer blade to push snow. Let the snowblower work its way through deep drifts. If the speed of your tractor is too fast, the snowblower may become overloaded and clog. For best results, raise the snowblower and remove a top layer of snow. A second pass with the snowblower will remove the remaining snow.

IMPORTANT: Use full engine RPM when removing wet, sticky snow. Low engine RPM will tend to clog the chute.



WARNING: To avoid serious personal injury: Do not use hands or feet to unclog chute. Do not attempt to clear clogged chute of snow while tractor engine is running. If the chute clogs, disengage the drive shaft, shut off the tractor engine, remove the ignition key, wait for all movement to stop, and then clear the snow from the chute.

A definite pattern of operation is required to thoroughly clean the snow area. These patterns will avoid throwing snow in unwanted places as well as eliminating a second removal of snow

PATTERN 1

DISCHARGE SNOW BOTH SIDES

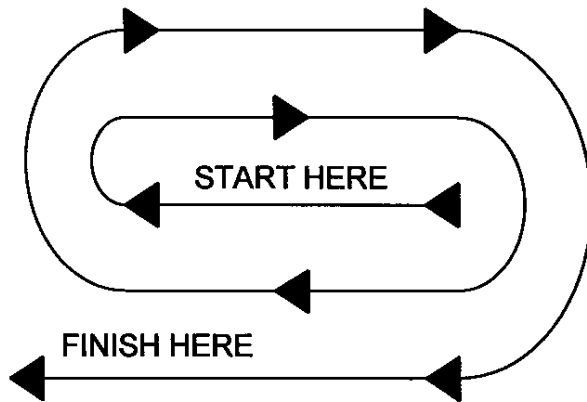

DISCHARGE SNOW BOTH SIDES

PATTERN 2

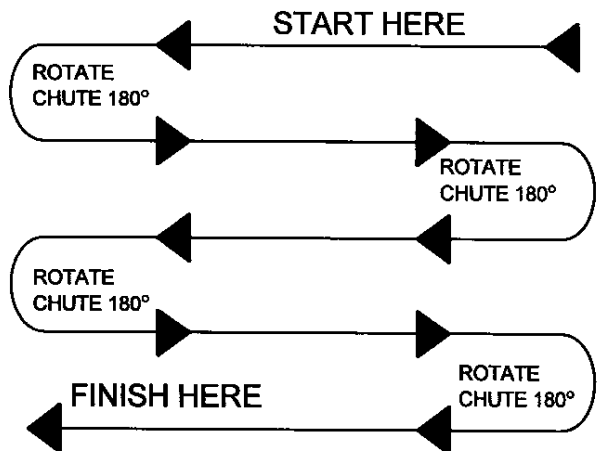

DISCHARGE SNOW THIS SIDE ONLY

Where it is possible to throw the snow to the left and right (above), as on a long driveway, it is advantageous to start in the middle. Plow from one end to the other, throwing snow to both sides without changing the direction of the discharge guide.

If the snow can only be thrown to one side of the driveway or sidewalk (above), start on the opposite side. At the end of the first pass, rotate the discharge guide 180 degrees for the return pass. At the end of each succeeding pass, rotate the discharge guide 180 degrees to maintain direction of throw in the same area.

MAINTENANCE

MAINTENANCE

ALWAYS USE GENUINE PARTS WHEN REPLACEMENT PARTS ARE REQUIRED

Storage

1. Check hardware at regular intervals to ensure it is always tightened properly.
2. Never park the tractor inside a building where an open flame or sparks are present. Allow the engine to cool down before storing in any enclosure.
3. Run the snowblower a few minutes after blowing snow to prevent freeze up of the auger and fan.



WARNING: Provide adequate blocking before working under the snowblower when in raised position.

Hydraulic System Oil

Check oil level before each use. Refer to the tractor's operation's manual for the type of oil to use. By default use ISOVG32.



ATTENTION: Escaping hydraulic/diesel fluid under pressure can penetrate the skin causing severe injuries.

- Do not use your hands to check for leaks. Use a piece of cardboard or paper to search for leaks.

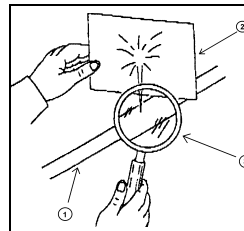
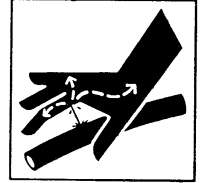

1. Hydraulic line
2. Cardboard
3. Magnifying glass

- Shut engine off and relieve pressure before connecting or disconnecting lines.
- Tighten all connections before starting engine or pressurizing lines.
- If any fluid is injected into the skin, obtain medical attention immediately or gangrene may result.

MAINTENANCE

LUBRICATION

Use a grease gun and lubricate as follows:

DESCRIPTION	INTERVAL	LUBRICATION REQUIRED
Bearing	24 hours of use	Grease the auger bearing
Hydraulic system	After each use	Check the tractor's oil level
	Once a year	Change the oil
Chute	24 hours of use	Grease the underside of the retaining plates (item 2)

REGULAR INSPECTIONS

DESCRIPTION	INTERVAL	LUBRICATION REQUIRED
Flow restrictor (items 1)	50 hours of use	Check that the hole is not obstructed
	200 hours of use	Replace with the appropriate hole size
Hoses	At each lubrication	Check for leaks
Hydraulic motor	At each lubrication	Check for leaks
Hydraulic block	At each lubrication	Check for leaks
Skid shoes / Cutting edge	100 hours of use	Check for wear and change if needed
Housing / Fan/Auger & Oil cooler located under the snowblower's upper	100 hours of use	Repair if needed
Hardware	24 hours of use	Check and tighten if needed

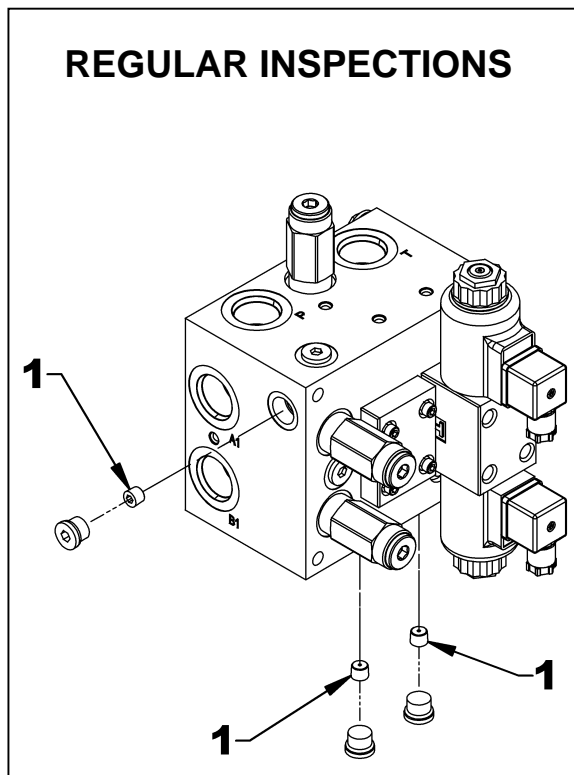
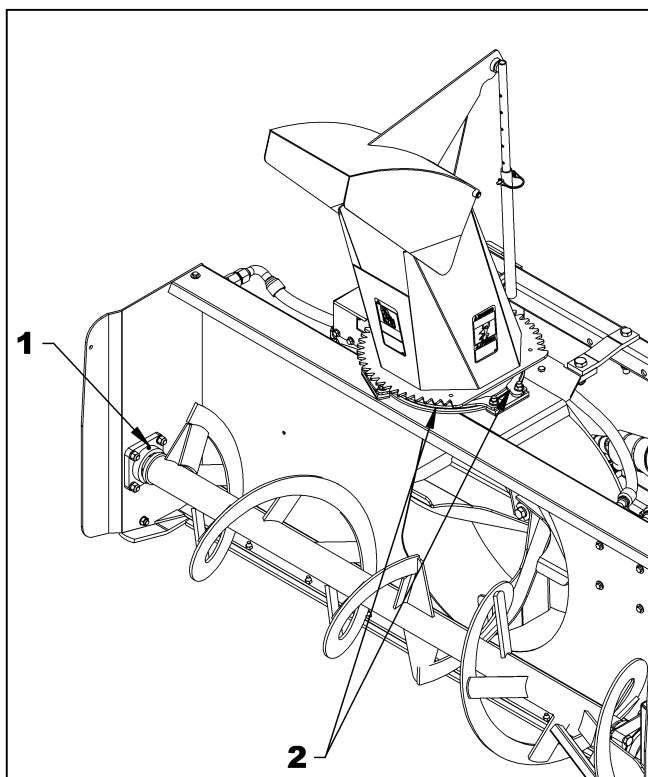

MAINTENANCE

TROUBLESHOOTING

Optimum Performance

IMPORTANT: The optimum performances of the snowblower are only achieved after 10 to 15 minutes of snowblower operation. It is therefore important to ensure that the hydraulic oil reaches a temperature of over 40° C before judging the snowblower's performances.

The snowblower performances are very sensitive to the hydraulic pressure. The higher the pressure is (while remaining under 3000 psi) the more the performances of the snowblower will be high.

The following chart serves as a guide in case of a malfunction. If the problem is not solved after taking the appropriate corrective measure, contact your dealer.

⚠ WARNING: Several corrective measures present a certain risk, which may cause serious injuries or death.

Only a qualified person, familiar with the risks associated with hydraulics, electricity and machinery should perform the repairs. Review the safety precautions at the beginning of this manual.

⚠ WARNING: Hot engine parts and hydraulic oil can cause serious burns. Always let the engine cool before proceeding with repairs or maintenance.

⚠ WARNING: Hydraulic oil temperature must never exceed 85°C, failure to do so could damaged the snowblower hydraulic components.

PROBLEM	CORRECTIVE MEASURE
1. The auger and fan do not turn	<ul style="list-style-type: none"> • Check if an object is blocking the fan or auger • Check the tractor controls • Check for oil leaks • Check tractor's oil level and add some if needed • Check that the input and output hoses are connected • Check that the input and output hoses are in the right position, if not reverse their position • Check if the flow restrictor is obstructed and replace if needed
2. The auger and fan are turning in reverse	<ul style="list-style-type: none"> • Check that the hoses are connected correctly to the hydraulic manifold and reverse their position if necessary
3. The snow is not being ejected from the chute	<ul style="list-style-type: none"> • Check if the fan is turning, refer to problem # 1 • Check if the fan is turning in the right direction, refer to problem # 2 • Check if the snow output is obstructed, unclog with a 36" stick
4. The snowblower clogs up easily	<ul style="list-style-type: none"> • Check the viscosity of the hydraulic oil • Check tractor's oil level and add some if needed • Check if the engine is at full RPM • Check the tractor's hydraulic pressure • Check the tractor's hydraulic flow • Check if the flow restrictor is obstructed and replace if needed • Check if the sequence valve is working and adjust or replace if needed

MAINTENANCE

PROBLEM	CORRECTIVE MEASURE
5. Snow doesn't enter the snowblower properly	<ul style="list-style-type: none"> • Check the viscosity of the hydraulic oil • Check tractor's oil level and add some if needed • Check if the engine is at full RPM • Check the tractor's hydraulic pressure • Check the tractor's hydraulic flow • Check is the flow restrictor is worn and replace if needed • Check the motor and auger relief valve • Check if the sequence valve is working and adjust or replace if needed
6. The snow is not thrown very far	<ul style="list-style-type: none"> • The engine is not at full RPM • Check tractor's oil level and add some if needed • Check the tractor's hydraulic pressure, adjust if too low • Check the tractor's hydraulic flow • Reduce the ground speed (Refer to Operation section) • Check the hoses for leaks, replace if needed • Check if the flow restrictor is obstructed and replace if needed • Check the motor and fan relief valve • The sequence valve is not adjusted properly, adjust or replace if needed
7. The chute or deflector hydraulic rotation does not operate	<ul style="list-style-type: none"> • Check if the snowblower is engaged • Check if the attachment flow restrictor is obstructed, replace if needed • Check if the harness or tractor fuse is burnt • Check if the hoses and wires are connected properly
8. The chute or deflector hydraulic rotation is working, but in a erratic way	<ul style="list-style-type: none"> • The engine is not revving at full RPM • Check for dirt in the oil and replace if needed • Check if the hoses and wires are connected properly • Check if the attachments flow restrictor is obstructed, replace if needed
9. The deflector electric rotation does not operate	<ul style="list-style-type: none"> • Check if the electrical wires and connections are connected properly • Check if the fuse is burnt
10. The deflector electric rotation is working, but in a erratic way	<ul style="list-style-type: none"> • Check if the electrical wires are connected properly • Check the battery's voltage
11. The hydraulic motor of the auger or the fan or the rotation or the deflector loses oil from the shaft	<ul style="list-style-type: none"> • Check if the maximum hydraulic pressure of the machine is inferior to the permitted limit. • Check if the maximum return pressure is inferior to the permitted limit. • Check if the hydraulic motors relief valves work well. • Replace the motor seal kit. • Change motor.

MAINTENANCE

Adjustment of the V.A.C. System

NOTE: Your snowblower was adjusted at the factory to achieve optimum performances. However, it may be necessary to readjust it, depending on the machine you use with your snowblower. To adjust, read the following instructions:

IMPORTANT:

- Before any adjustment, operate the snowblower for at least 15 minutes, in order to be able to judge its performances.
- Never move the adjustment more than two turns, in one way or another.
- Always adjust when the snowblower and the machine are shut off.

(Refer to the figure for V.A.C. System adjustments)

Before making any adjustments, you must count how many turns the adjustment is unscrewed, and take note of it. The V.A.C. system is adjusted at the factory on a test bench specially made for this matter. If you lose your adjustment, you will need to purchase a pre-adjusted valve to replace yours.

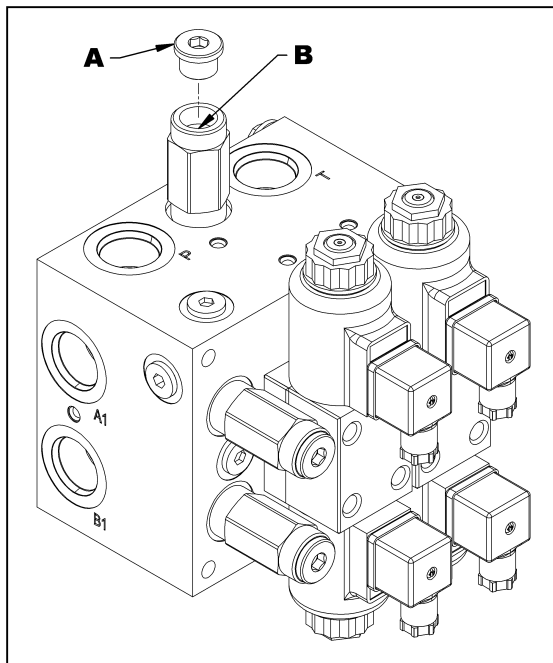

When is it necessary to adjust the V.A.C. system?

1. If the auger jams easily or slows down a lot under light loads of snow and if the fan expels snow without difficulty:
 - Loosen the locknut (item A), turn the adjustment screw (item B) half a turn clockwise. Tighten the locknut (item A).
 - If you notice an improvement but not enough, repeat the procedure but without exceeding two turns total.
2. If the fan tends to slow down under light loads of snow and that the distance of snow discharge is uneven, depending on the load of snow to blow:
 - Loosen the locknut (item A), turn the adjustment screw (item B) half a turn counterclockwise. Tighten the locknut (item A).
 - If you notice an improvement, but not enough, repeat the procedure but without exceeding two turns total.

NOTE: If you do not notice any change after the adjustments, the problem is at another level.

SPECIFICATIONS

SPECIFICATIONS	H64A	H76A	H84A
Cutting width – in (cm)	64 (162)	76 (193)	84 (213)
Cutting height – in (cm)	26 (66)	26 (66)	26 (66)
Distance between mounting plate & housing – in (cm)	11 1/4 (28)	9 9/16 (24)	9 9/16 (24)
Impeller diameter – in (cm)	24 (61)	24 (61)	24 (61)
Impeller depth – in (cm)	6 3/4 (17)	8 7/16 (21)	8 7/16 (21)
Number of blades	4	4	4
Auger diameter – po (cm)	15 (38)	15 (38)	15 (38)
Electric chute rotation	option	option	option
Hydraulic chute rotation	option	option	option
Manual chute deflector adjustment	standard	standard	standard
Electric chute deflector adjustment	option	option	option
Hydraulic chute deflector adjustment	option	option	option
Drift cutters – widens cutting width by 6" (15 cm)	option	option	option
Replaceable cutting edge	standard	standard	standard
Adjustable skid shoes	standard	standard	standard
Universal skid steer mount kit	option	option	option
Three point rear mount hitch	option	option	option
Universal mount kit for front loader	option	option	option
Fan drive	hyd. motor	hyd. motor	hyd. motor
Auger drive	hyd. motor	hyd. motor	hyd. motor
V.A.C. hydraulic drive system	standard	standard	standard
Recommended flow - GPM	12 @ 20	18 @ 25	18 @ 25
Recommended pressure - PSI	2100 @ 3300	2100 @ 3300	2100 @ 3300
Approximate weight – lbs (kg)	591 (268)	657 (298)	702 (319)

Specifications are subject to change without notice

PERFORMANCE CHART

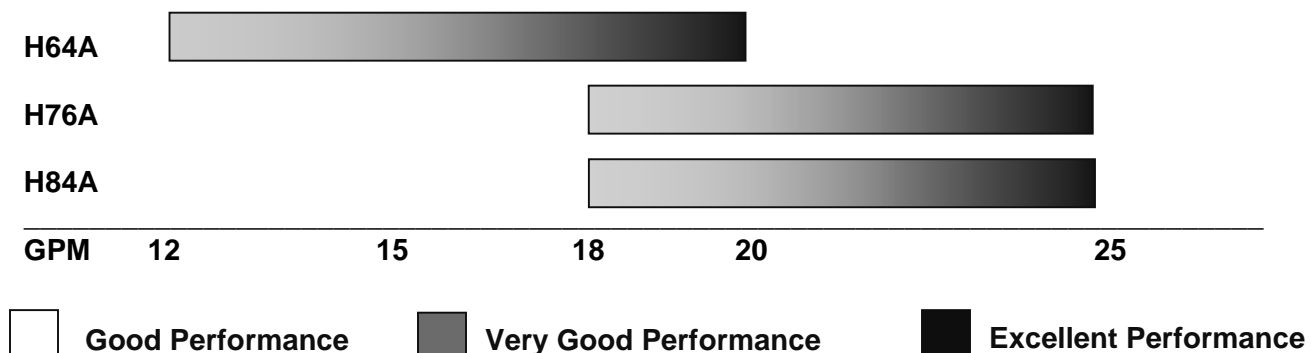

WARRANTY



RADTECH warrants to the original buyer that the equipment is free from defects in material and workmanship. RADTECH's obligation, under this warranty, will be limited to the repair or replacement of any non-wear part or component, which RADTECH finds to be defective within **one year** from the date of original purchase (unless otherwise-specified). The applicable warranty period for commercial or rental use shall be ninety (90) days from the date of purchase

In no event shall RADTECH be liable for consequential, special, direct or indirect damages incurred by the buyer/user.

All components not manufactured by RADTECH (such as motors, actuators, hydraulic components, tires, ...etc.) are covered by the original manufacturer's warranty in conjunction with RADTECH

RADTECH's obligation under this warranty shall be limited to repairing or replacing, free of charge to the original purchaser, any part that, in RADTECH's judgment, shall show evidence of such defect, provided the **distributor** returns the part prepaid within thirty (30) days from date of failure.

This warranty shall not be interpreted to render RADTECH liable for injuries or damages of any kind or nature to person or property. This warranty does not extend to losses because of delays, or to any expenses or losses incurred for labor, substitute machinery, rental or for any other reason.

Except as set forth above, RADTECH shall have no obligation or liability of any kind on account of any of its equipment and shall not be liable for special or consequential damages. RADTECH makes no other warranty, expressed or implied, and specifically, RADTECH disclaims any implied warranty or merchantability or fitness for a particular purpose. **Some states or provinces do not permit limitations or exclusions of implied warranties or incidental or consequential damages, so the limitations or exclusions in this warranty may not apply.**

This warranty is subject to any existing conditions of supply, which may directly affect our ability to obtain materials or manufacture replacement parts. RADTECH reserves the right to make improvements in design or changes in specifications at any time, without incurring any obligation to owners of units previously sold.

No one is authorized to alter, modify or enlarge this warranty nor the exclusions, limitations and reservations.

2835 Chemin de l'Aéroport, Thetford Mines (Québec) G6G 5R7

Tel.: (418) 338-4499 Fax: (418) 388-6090
Internet : www.radinter.com e-mail : radtech@radinter.com

TORQUE SPECIFICATION TABLE

GENERAL SPECIFICATION TABLE

Use the following torques when special torques are not given

NOTE: These values apply to fasteners as received from supplier, dry, or when lubricated with normal engine oil. They do not apply if special graphited or moly sidulphide greases or other extreme pressure lubricants are used. This applies to both UNF and UNC threads.

BOLT HEAD IDENTIFICATION MARKS AS PER GRADE NOTE: MANUFACTURING MARKS WILL VARY.																					
		Torque		Torque		Torque		Torque		Torque		Torque		Torque							
BOLT SIZES		Pounds-Foot		Newtons-Meter		Pounds-Foot		Newtons-Meter		Pounds-Foot		Newtons-Meter		Pounds-Foot		Newtons-Meter					
Inches	Millimeters	MIN.	MAX.	MIN.	MAX.	MIN.	MAX.	MIN.	MAX.	MIN.	MAX.	MIN.	MAX.	MIN.	MAX.	MIN.	MAX.				
1/4	6.35	5	6	6.8	8.13	9	11.0	12.2	14.9	12	15	16.3	30.3								
5/16	7.94	10	12	13.6	16.3	17	20.5	23.1	27.8	24	29	32.5	39.3								
3/8	9.53	20	23	27.1	31.2	35	42.0	47.5	57.0	45	54	61.0	73.2								
7/16	11.11	25	30	40.7	47.4	54	64.0	73.2	86.8	70	84	94.9	113.9								
1/2	12.70	45	52	61.0	70.5	80	96.0	108.5	130.2	110	132	149.2	179.0								
9/16	14.29	65	75	88.1	101.6	110	132.0	149.2	179.0	160	192	217.0	260.4								
5/8	15.88	95	105	128.7	142.3	150	180	203.4	244.1	220	264	298.3	358.0								
3/4	19.05	150	185	203.3	250.7	270	324	366.1	439.3	380	456	515.3	618.3								
7/8	22.23	160	200	216.8	271.0	400	480	542.4	650.9	600	720	813.6	976.3								
1	25.40	250	300	338.8	406.5	580	696	786.5	943.8	900	1080	1220.4	1464.5								
1 1/8	25.58	-	-	-	-	800	880	1084.8	1193.3	1280	1440	1735.7	1952.6								
1 1/4	31.75	-	-	-	-	1120	1240	1518.7	1681.4	1820	2000	2467.9	2712.0								
1 3/8	34.93	-	-	-	-	1460	1680	1979.8	2278.1	2380	2720	3227.3	3688.3								
1 1/2	38.10	-	-	-	-	1940	2200	2630.6	2983.2	3160	3560	4285.0	4827.4								

METRIC BOLT TORQUE SPECIFICATIONS

Size of screw	Grade No.	Pitch (mm)	Coarse thread				Fine Thread			
			Pounds-Foot		Newtons-Meter		Pounds-Foot		Newtons-Meter	
			MIN.	MAX.	MIN.	MAX.	MIN.	MAX.	MIN.	MAX.
M6	4T	1.0	3.6	5.8	4.9	7.9	-	-	-	-
	7T		5.8	9.4	7.9	12.7	-	-	-	-
	8T		7.2	10	9.8	13.6	-	-	-	-
M8	4T	1.25	7.2	14	9.8	19.0	12	17	16.3	23.0
	7T		17	22	23	29.8	19	27	25.7	36.6
	8T		20	26	27.1	35.2	22	31	29.8	42
M10	4T	1.5	20	25	27.1	33.9	20	29	27.1	39.3
	7T		34	40	46.1	54.2	35	47	47.4	63.7
	8T		38	46	51.5	62.3	40	52	54.2	70.5
M12	4T	1.75	28	34	37.9	46.1	31	41	42	55.6
	7T		51	59	69.1	79.9	56	68	75.9	92.1
	8T		57	66	77.2	89.4	62	75	84	101.6
M14	4T	2.0	49	56	66.4	75.9	52	64	70.5	86.7
	7T		81	93	109.8	126	90	106	122	143.6
	8T		96	109	130.1	147.7	107	124	145	168
M16	4T	2.0	67	77	90.8	104.3	69	83	93.5	112.5
	7T		116	130	157.2	176.2	120	138	162.6	187
	8T		129	145	174.8	196.5	140	158	189.7	214.1
M18	4T	2.0	88	100	119.2	136	100	117	136	158.5
	7T		150	168	203.3	227.6	177	199	239.8	269.6
	8T		175	194	237.1	262.9	202	231	273.7	313
M20	4T	2.5	108	130	146.3	176.2	132	150	178.9	203.3
	7T		186	205	252	277.8	206	242	279.1	327.9
	8T		213	249	288.6	337.4	246	289	333.3	391.6

TORQUE SPECIFICATION TABLE

TORQUE SPECIFICATION TABLE FOR HYDRAULIC FITTINGS

Use the following torques when a specific torque is not given. Note: These values apply to fittings when dry. These values do not apply if lubricants are used..

SIZE OF FITTINGS	TORQUE	
	foot-pounds	Newton-meters
SIZE (JIC) - INCHES		
03 - 3/8" - 24	8-9	12-13
04 - 7/16" - 20	13-15	18-20
05 - 1/2" - 20	14-15	19-21
06 - 9/16" - 18	23-24	32-33
08 - 3/4" - 16	40-43	55-57
10 - 7/8" - 14	43-48	59-64
12 - 1 1/16" - 12	68-75	93-101
14 - 1 3/16" - 12	83-90	113-122
16 - 1 5/16" - 12	112-123	152-166
20 - 1 5/8" - 12	146-161	198-218
24 - 1 7/8" - 12	154-170	209-230
32 - 2 1/2" - 12	218-240	296-325

SIZE (ORB) - INCHES	foot-pounds	Newton-meters
03 - 3/8" - 24	8-10	11-13
04 - 7/16" - 20	14-16	20-22
05 - 1/2" - 20	18-20	24-27
06 - 9/16" - 18	24-26	33-35
08 - 3/4" - 16	50-60	68-78
10 - 7/8" - 14	72-80	98-110
12 - 1 1/16" - 12	125-135	170-183
14 - 1 3/16" - 12	160-180	215-245
16 - 1 5/16" - 12	200-220	270-300
20 - 1 5/8" - 12	210-280	285-380
24 - 1 7/8" - 12	270-360	370-490

TORQUE SPECIFICATION TABLE

SIZE (NPT) - INCHES	Torque FFT
1/8" - 27	2.0 - 3.0
1/4" - 18	2.0 - 3.0
3/8" - 18	2.0 - 3.0
1/2" - 14	2.0 - 3.0
3/4" - 16	2.0 - 3.0
1" - 11 1/2"	1.5 - 2.5
1 1/4" - 11 1/2"	1.5 - 2.5
1 1/2" - 11 1/2"	1.5 - 2.5

ASSEMBLY

The method used to assemble fittings with NPT threads is in two stages. First tighten firmly by hand then tighten one again according to the number of turns listed on the above table. The following method is recommended to minimize the risks of leaks and/or damages to the parts.

1. Inspect threads and tapping to make sure they are clean.
2. Apply a sealant/lubricant product to the NPT threads (Teflon covered threads are preferable to other lubricating products). If PTFE tape (Teflon) is used, make 1,5 or 2 turns clockwise.

Attention: More than 2 turns can cause distortion or cracks in the orifice.

3. Tighten the fitting by hand.

4. Screw the fitting the number of turns listed on the above table making sure that in the case of a shape fitting the end is aligned to the desired position. **Never unscrew a fitting to obtain the proper alignment.**
5. If the leak persists after having followed the preceding instructions, check that the threads are not damaged and the number of seated threads.

If the threads are very damaged, replace the fitting. If the tapping is damaged, retap if possible or replace the part.

Usually, the number of threads seated is between 3, 5 and 6. If the range is different it would indicate that the fitting was tightened too much or not enough or that the tightening was not within thread tolerances. If the fitting is not tight enough, tighten but never more than one turn. If it's too tight, control the threading and tapping and replace the section that has threads that are not within tolerances.

Manufactured by:



RAD TECHNOLOGIES INC.

Division Thetford Mines

2835, Chemin de l'Aéroport

Thetford Mines, Québec, Canada, G6G 5R7

Tel.: (418) 338-4499 - Fax.: (418) 338-6090

E-mail : radtech@radinter.com

Internet : www.radinter.com

Printed in Canada