

OWNER'S MANUAL

OM0460SB-A / Rev0 09-17

BLIZZARD

B84C-L **3-Point Snowblower**

SERIAL NO. 21700001 AND UP

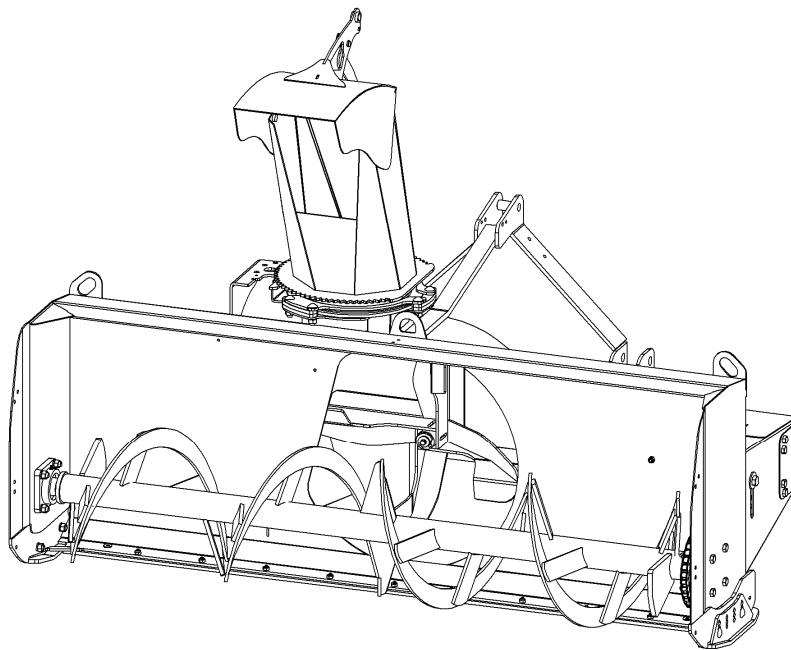

30 HP @ 50 HP (PTO)

PLEASE READ THIS MANUAL CAREFULLY
KEEP READY AT ALL TIMES

INTRODUCTION

TO THE PURCHASER

All products are designed to give safe, dependable service if they are operated and maintained according to instructions. **Read and understand this manual before operation, and keep it in your files for further reference.**

This manual has been prepared to assist the owner and operators in the safe operation and suitable maintenance of the equipment. The information is applicable to products at the time of manufacture and does not include modifications made afterwards.

Read and understand this operator's manual before attempting to put equipment into service. Familiarize yourself with the operating instructions **AND ALL THE SAFETY RECOMMENDATIONS** contained in this manual and those labeled on the equipment and on the machine. Follow the safety recommendations and make sure that those with whom you work follow them.

TO THE DEALER

Give this manual to the owner upon delivery of the equipment.

TO THE PURCHASER AND THE DEALER

Illustrations

The illustrations may not necessarily reproduce the full detail and the exact shape of the parts or depict the actual models, but are for reference only.

Direction Reference

All references to right and left, forward or rearward are from the operator seat.

To assist your dealer in handling your needs, please record hereafter the model number and serial number of your equipment and machine. It is also advisable to supply them to your insurance company. It will be helpful in the event that equipment or machine is lost or stolen

MODEL: _____

SERIAL NUMBER: _____

DATE OF PURCHASE: _____

DEALER NAME: _____

DEALER TELEPHONE NUMBER: _____

INTRODUCTION

All products are designed to give safe, dependable service if they are operated and maintained according to instructions. **Read and understand this manual before operation.** It is the owner's responsibility to be certain anyone operating this product reads this manual, and all other applicable manuals, to become familiar with this equipment and all safety precautions. Failure to do so could result in serious personal injury or equipment damage. If you have any questions, consult your dealer.

SAFETY FIRST

This symbol, the industry's "Safety Alert Symbol", is used throughout this manual and on labels on the machine itself to warn of the possibility of personal injury. Read these instructions carefully. It is essential that you read the instructions and safety regulations before you attempt to assemble or use this unit.

 **DANGER :** Indicates an imminently hazardous situation which, if not avoided, will result in death or serious injury.

 **WARNING :** Indicates a potentially hazardous situation which, if not avoided, could result in death or serious injury.

 **CAUTION :** Indicates a potentially hazardous situation which, if not avoided, may result in minor or moderate injury.

IMPORTANT : Indicates that equipment or property damage could result if instructions are not followed.

NOTE : Gives helpful information.

TABLE OF CONTENT

INTRODUCTION	1
TABLE OF CONTENT	3
SAFETY INFORMATION	5
GENERAL SAFETY INFORMATION – Pictograms	8
SPECIFICATIONS.....	10
SAFETY LABELS	11
ESTIMATED ASSEMBLY TIME	12
ASSEMBLY	13
Snowblower assembly B84C-L.....	13
Installation of the Chute	13
Snowblower installation with a 3-Point Hitch.....	14
Snowblower installation with a Quick Hitch	15
Preparation of the driveline.....	16
Recommendations for Driveline Angles	16
Angles at Each End of Driveline.....	16
Determining Driveline Length	17
Driveline installation	19
Remove the Snowblower from the Tractor	20
OPERATION	21
General Preparation	21
Controls	21
Up and Down Control	21
Work and Travel Speed.....	21
Engaging the Drive Mechanism	21
Manual Rotation - Option	21
Hydraulic Rotation - Option	21
Manual Deflector	22
Hydraulic Deflector - Option	22
Electric Deflector - Option	22

TABLE OF CONTENT

OPERATION (continued)	
Adjustments	23
Skid Shoes Adjustment	23
Drive Chain Tension Adjustment.....	23
Unclog the Chute.....	23
Snow Removal Methods	24
MAINTENANCE.....	25
Maintenance	25
Maintenance Schedule	26
Shearbolts	26
Lubrication	27
Gearbox	28
Oil Level – Oil Fill Up.....	28
Oil Change.....	28
TROUBLE SHOOTING	29
STORAGE	33
PARTS.....	34
Snowblower 84" - FRONT.....	34
Snowblower 84" - REAR.....	36
Chute and Deflector	38
Gearbox - 663485	40
Driveline - 662194.....	41
AVAILABLE OPTIONS	42
TORQUE SPECIFICATION TABLE	43
ADAPTER INSTALLATION PROCESS.....	44



SAFETY INFORMATION

Children

Tragic accidents can occur if the operator is not alert to the presence of children. Children are generally attracted to machines and the work being done. Never assume children will remain where you last saw them

1. Keep children out of the operating area and under the watchful eye of another responsible adult.
2. Be alert and turn machine off if children enter the work area.
3. Before and when backing, look behind for small children.
4. Never carry children while operating the machine. They may fall off and be seriously injured or interfere with the safe operation of the machine.
5. Never allow children to play on the machine or attachment even when the machine is turned off.
6. Never allow children to operate the machine even under adult supervision.
7. Use extra care when approaching blind corners, shrubs, trees, or other obstructions that might hide children from sight.

Before Operation

1. Read and understand both the machine AND implement operator's manual before using the snowblower. Know how to operate all controls and how to stop the unit and disengage the controls quickly. Lack of knowledge can lead to accidents.
2. Park the machine/implement on level ground, set the parking brake, lower the implement to the ground, place all control levers in neutral, shut off the engine and remove the ignition key and allow the rotating parts to stop BEFORE making any implement adjustments, repairs or inspections.
3. Keep clear of all rotating parts. Do not put hands or feet under, or into snowblower and subframe with engine running.

4. For your safety, do not work under any hydraulically supported machine elements, they may creep down, suddenly drop or be accidentally lowered. Do not use loader, quick hitch, or an implement as a jack for servicing.
5. Do not operate the machine/implement that is defective or has missing parts. Make sure that all recommended maintenance procedures are completed before operating the unit.
6. Keep the machine/implement clean. Snow, dirt or ice build-up can lead to malfunction or personal injury from thawing and refreezing in garage. Inspect and clean every rotating parts.
7. Do not modify or alter this implement or any of its components, or any implement function without first consulting your dealer. The manufacturer will not claim responsibility for fitment of unapproved parts and/or accessories and any damages as a result of their use.
8. Verify that all machine/implement safety protective devices are in place. Shields, guards and covers must be correctly installed at all times. When necessary to remove these for servicing, cleaning, or repair work, they must be reinstalled immediately.
9. Always make sure all implement components are properly installed and securely fastened.
10. Check that all machine/implement drivelines are in good working order.
11. Check for moving parts excessive wear regularly. ALWAYS USE GENUINE PARTS WHEN REPLACEMENT PARTS ARE REQUIRED.
12. Prior to operation, clear work area and mark all curbs, pipes, etc. that cannot be moved.
13. Inspect the machine/implement after striking any foreign object to assure that all machine/implement parts are safe and secure and not damaged.
14. Handle fuel with care, as it is highly flammable. Use approved fuel container.
15. Never add fuel to a running engine or a hot engine.
16. Fill fuel tank outdoors with extreme care. Never fill fuel tank indoors. Replace fuel cap securely and wipe up spilled fuel. Always refuel using a properly grounded system.



SAFETY INFORMATION

17. Check all machine controls regularly and adjust where necessary. Make sure that the brakes are evenly adjusted. Periodically check all nuts and bolts for tightness, especially wheel hub and rim nuts.
18. Make sure the machine is counterweighted and has tire chains for better traction and stability as recommended by your dealer. Weights provide the necessary balance to improve stability, traction and steering. Use only those recommended by your dealer.
19. Prolonged exposure to loud noise can cause impairment or loss of hearing. Wear a suitable hearing protective device such as earmuffs or earplugs to protect against objectionable or uncomfortable noises.
8. Park the machine/implement on level ground, place the transmission in neutral, set the parking brake, disengage the driving system, lower the equipment to the ground, place all levers including auxiliary control levers in neutral, shut off the engine and remove the ignition key **BEFORE LEAVING THE MACHINE.**
9. Always drive the machine at speeds compatible with safety, especially when operating over rough ground, crossing ditches, slippery surface or when turning.
10. Operate only with good visibility and during daylight hours, or when the area is well lit with bright artificial light.
11. Do not run the engine indoors except when starting engine and transporting attachment in or out of building. Carbon monoxide gas is colorless, odorless and deadly.

During Operation

1. Never allow anyone to operate the machine and implement until they have read the manuals completely and are thoroughly familiar with their basic operation. Lack of operating knowledge can lead to accidents.
2. Do not allow anyone to ride on the machine/implement at any time. The only one allowed is the operator that **MUST** sit in the driver seat.
3. Never allow anyone near the work area. The debris that can be thrown could cause serious personal injuries.
4. Never stand alongside of the implement while the engine is running.
5. Never operate the implement without safety protective devices in place. All machine/implement shields, guards and covers must be correctly installed at all times.
6. Keep clear of all rotating parts. Do not put hands or feet under, or into the implement with engine running.
7. If the implement starts to vibrate abnormally, disengage the PTO, stop the engine immediately and check for cause. Excessive vibration is generally a sign of trouble.
12. Exercise extreme caution when operating on or crossing a gravel drive, walks, or roads. Stay alert for hidden hazards or traffic.
13. Use extra caution when backing up.
14. Operate up and down (not across) intermediate slopes. Avoid sudden starts and stops. Drive machine backwards up steeper slopes with the implement off. Then operate as you travel down the slope.
15. Never park the machine on a steep slope. Do not attempt to operate on steep slopes. If operating on slopes is necessary, exercise extreme caution when changing direction.
16. Disengage power to implement when transporting or when not in use

SAFETY INFORMATION

Stay Clear of Rotating Drivelines



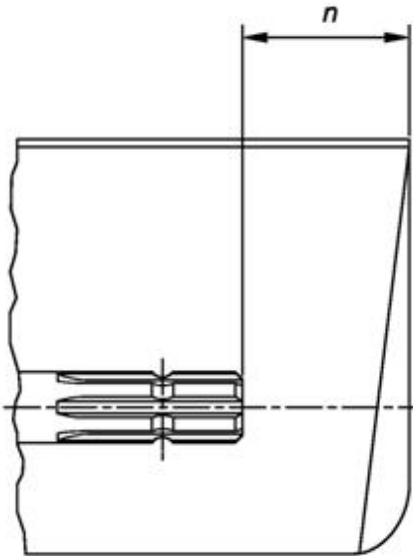







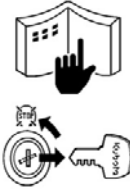



1. Entanglement in rotating driveline can cause serious injury or death.
2. Keep tractor master shield and driveline shields in place at all times. Make sure rotating shields turn freely.
3. Wear close fitting clothing. Stop the engine and be sure that PTO driveline is stopped before making adjustments, connections, or cleaning out PTO driven equipment.
4. Do not install any adapter device between the tractor and the primary implement PTO drive shaft that will allow a 1000 rpm tractor shaft to power a 540 rpm implement at speeds higher than 540 rpm.
5. To use the blower with PTO at 1000 rev / min, see your dealer to install the appropriate set of gears.
6. Do not install any adapter device that results in a portion of the rotating implement shaft, tractor shaft, or the adapter to be unguarded. The tractor master shield shall overlap the end of the splined shaft and the added adaptor device as outlined in the table.



PTO Type	Diameter	Splines	$n \pm 5 \text{ mm (0.20 in.)}$
1	35 mm (1.378 in.)	6	85 mm (3.35 in.)
2	35 mm (1.378 in.)	21	85 mm (3.35 in.)
3	45 mm (1.772 in.)	20	100 mm (4.00 in.)







GENERAL SAFETY INFORMATION

	<p>BEFORE YOU START SERVICE</p> <ul style="list-style-type: none"> • Read all instructions and safety instructions in this manual and on your machine safety decals. • Clean the work area and machine. • Park the machine on a stable and level ground, and set the parking brake. • Lower the implement to the ground. • Stop the engine, then remove the key. • Disconnect the battery negative cable. • Hang a "DO NOT OPERATE" tag in the operator station. 		<p>No Smoking or Open Flames while Fueling</p> <ul style="list-style-type: none"> • Fuel is extremely flammable and dangerous. Never smoke near fuel. If fuel is spilled on the machine, its engine, or electrical parts, it may cause a fire. If fuel is spilled, wipe it all up immediately. • Never smoke while filling the machine with fuel. And always tighten the fuel cap securely and wipe up any spilled fuel.
	<ul style="list-style-type: none"> • When performing maintenance on the equipment, hang the DO NOT OPERATE sign where it will be obvious from and around the driver's seat. • When performing maintenance or repairs, always lower attachments to the ground, stop the engine and secure the tracks with blocks. • When performing maintenance on the equipment, always disconnect the negative battery cable. • Before using tools, make sure you understand how to use them correctly and use tools in good condition and of the right size for the job. 		<ul style="list-style-type: none"> • Before getting on/off of the machine, clean off around the steps so there is no mud on them. Always give yourself 3-point support when getting on/off the machine. <p>CAUTION</p> <ul style="list-style-type: none"> • 3-point support means using both legs and one hand or both hands and one leg as you climb up/down.
	<p>START SAFELY</p> <ul style="list-style-type: none"> • Do not do the procedures below when you start the engine. <ul style="list-style-type: none"> – short across starter terminals – bypass the safety start switch • Do not alter or remove any part of machine safety system. • Before you start the engine, make sure that all shift levers are in neutral positions or in disengaged positions. • Do not start the engine when you stay on the ground. Start the engine only from operator's seat. 		<ul style="list-style-type: none"> • Do not remove the radiator cap when the engine operates, or immediately after it stops. If not, hot water can spout out from the radiator. Only remove the radiator cap when it is at a sufficiently low temperature to touch with bare hands. Slowly loosen the cap to release the pressure before you remove it fully.
	<p>Starting the Machine Safely</p> <ul style="list-style-type: none"> • Before starting the engine, always sit in the driver's seat and make sure the area is safe and clear. • As it is dangerous, never start the engine from anywhere but the driver's seat. • Always check and make sure control lever(s) are not engaged before starting the engine. • Never start the engine by hot-wiring the starter circuit. This is not only dangerous, but may damage the machine. 		<ul style="list-style-type: none"> • The engine, muffler, radiator, hydraulic line, etc., have parts that remain very hot even after the engine has been stopped. Be sure to avoid these parts, as touching them can result in burns. Radiator coolant, hydraulic fluid and oil also remain hot. Therefore, do not attempt to remove caps and plugs, etc., before these fluids have sufficiently cooled. • Make sure the coolant temperature has dropped sufficiently before opening the radiator cap. Also, since the inside of the radiator is pressurized, when removing the cap, first loosen it to release the pressure before removing the cap completely.
	<ul style="list-style-type: none"> • Wear clothes appropriate for working on equipment. Do not wear loose-fitting clothes as they may catch on the machine controls. • When working on the equipment, use all safety gear, such as a helmet, safety glasses and shoes, that are required by law or regulation. • Never perform maintenance while drowsy or under the influence of alcohol or drugs. 		<ul style="list-style-type: none"> • Grease is under high pressure inside the hydraulic cylinder. It is very dangerous to loosen a grease nipple quickly as it may shoot off. Always loosen grease nipples slowly. • And never face a grease nipple while loosening it.
	<p>Be Ready for an Emergency</p> <ul style="list-style-type: none"> • Keep a first-aid kit and fire extinguisher close at hand so you can use it when needed. • Keep emergency contact information for doctors, hospitals and ERs handy. 		<p>PREVENT A FIRE</p> <ul style="list-style-type: none"> • Fuel is very flammable and explosive under some conditions. Do not smoke or let flames or sparks in your work area. • To prevent sparks from an accidental short circuit, always disconnect the battery negative cable first and connect it last. • The battery gas can cause an explosion. Keep the sparks and open flame away from the top of battery, especially when you charge the battery. • Make sure that you do not spill fuel on the engine.
	<p>KEEP A GOOD AIRFLOW IN THE WORK AREA</p> <ul style="list-style-type: none"> • If the engine is in operation, make sure that the area has good airflow. Do not operate the engine in a closed area. The exhaust gas contains poisonous carbon monoxide. 		<p>Dispose of Waste Fluids Properly</p> <ul style="list-style-type: none"> • Never dispose of waste fluids on the ground, in the gutter, a river, pond or lake. Always dispose of hazardous substances like waste oil, coolant and electrolytic fluid in accordance with the relevant environmental protection regulations. • Keep the safety plates clean so they can be read. If a safety plate is damaged and comes off or becomes illegible, put a plate with the same warnings back in its place.



GENERAL SAFETY INFORMATION

	<ul style="list-style-type: none"> The pressure in the hydraulic circuit stays at pressure even after the engine stops. Before removing parts, such as hydraulic devices from the machine, first release the pressure. Please note that when releasing residual pressure, the machine itself and/or implements may move without warning, so be very careful when releasing the pressure. Oil gushing out under pressure is extremely dangerous as it may pierce your skin or your eyes. Similarly, oil leaking out of pinholes is not visible. So when checking for oil leaks, always wear safety glasses and gloves and use a piece of cardboard or a wood block to shield yourself from oil. 		<ul style="list-style-type: none"> When you need to access the underside of the machine for maintenance purposes, but sure to support the machine with a safety stand. Getting under the machine while supporting the machine by machine's own hydraulic cylinder or using a hydraulic jack can be extremely dangerous in the event of a hydraulic fluid leakage or similar mishap. <p>(1) Safety stand (2) Secure point for safety stand</p>
	<ul style="list-style-type: none"> Do not open a fuel system under high pressure. The fluid under high pressure that stays in fuel lines can cause serious injury. Do not disconnect or repair the fuel lines, sensors, or any other components between the fuel pump and injectors on engines with a common rail fuel system under high pressure. Put on an applicable ear protective device (earmuffs or earplugs) to prevent injury against loud noises. Be careful about electric shock. The engine generates a high voltage of more than DC100 V in the ECU and is applied to the injector. 		<ul style="list-style-type: none"> Whenever it is necessary to open the engine covers or hood in order to service the machine, always prop them open. If it is absolutely necessary to run the engine while working on the machine, make sure you are clear of all rotating or moving parts. Also take care not to leave anything, such as tools or rags, near any moving parts.
	<ul style="list-style-type: none"> Engage the loader control valve lock to prevent accidental actuation when the implement is not in use or during transport. Do not utilize the valve lock for machine maintenance or repair. Do not perform machine maintenance with loader in the air. If possible, follow loader instructions to remove loader before performing maintenance. If the machine has a backhoe, engage swing and boom locks. 		

SPECIFICATIONS

	Specifications	B84C-L
General	Type	2 stage
	Direction of impeller rotation	CCW
	PTO power requirements	30 - 50 HP
	Shipping weight	715 Lbs
	Operating weight, incl. chute & hyd. deflector	665 Lbs
	Set-up time	60 min
	Working width	84"
	Working height	27 1/2"
	Overall width	85 1/4"
	Overall height (without chute)	32 1/4"
	Overall height (with chute closed)	59"
	Overall length	45 1/2"
Impeller	Impeller diameter	24"
	Impeller width	9"
	Number of impeller blade	4
	Impeller shaft diameter	1 3/8"
	Impeller RPM	540 RPM
Auger	Auger - Single / dual	Simple
	Main auger diameter	15"
	Auger driven system	Chain No.60
	Second auger diameter	N/A
	Second auger driven system	N/A
	Auger RPM	200 RPM
Housing	Housing thickness	11 Ga
	Side panel thickness	11 Ga
	Impeller housing thickness	10 Ga
Chute	Chute position	Right
	Rotation of the chute	Manual or hydraulic
	Flow restrictor (rotation)	Yes
	Flow restrictor (deflector)	No
	Hoses support	Yes
	Deflector adjustment (2 part chute)	Manual (hydr. in option)
	(3 part chute)	N/A
Cutting edge	Replaceable and reversible	Yes
	Cutting edge material	Carb. Steel
	Cutting edge dimension	3/8" x 1 1/2"
Skid shoes	Replaceable and reversible	Yes, 3 positions adjustable
	Skid shoe material	Carbon steel
Drive and Hitch	Main driving system	Driveline series 50
	Chain idler	Yes
	Parking stand	Yes
	Number of auger shear bolt	1 (on the drive shaft)
	Number of impeller shear bolt	1 (on the driveline)
	Type of hitch	3 pts, cat. 1 & 2
	Compatibility with quick hitch	Yes, cat. 1 only

ESTIMATED ASSEMBLY TIME

Refer to the following table for the estimated assembly time to open the package and assemble the equipment and options.

	3pt Snowblower
Estimated installation time, snowblower only	60 min
2nd installation time (on the tractor)	10 min
Estimated installation time of the Manual Rotation (BER0077)	25 min
Estimated installation time of the Hydraulic Rotation (BER0078)	25 min
Estimated installation time of the Hydraulic Deflector (BER0079A)	20 min
Estimated installation time of the Electric Deflector (BER0080)	45 min

The assembly times of the table are only a reference under normal conditions according to the following assumptions:

1. The assembly is done by a competent person who is familiar with the equipment.
2. The following tools and materials are prepared:
 - Wrench set (flat wrenches)
 - Ratchet & socket set
 - Cutting pliers
 - Security gloves

ASSEMBLY

⚠ WARNING: To avoid serious injury or death: Read and understand SAFETY INFORMATION on previous pages before installation and operation. Perform all assembly with the assembly properly secured and supported.

TRACTOR PREPARATION

See Dealer for Tractor Preparation information.

SNOWBLOWER ASSEMBLY

The snowblower is assembled at the factory except for the parts in the hardware bag provided with the snowblower, the chute and the options if appropriate. Use the present manual and lay out all parts for assembly. Separate bolts and nuts into various sizes. After assembly, torque all the bolts according to the **Torque Specification Table** at the end of the manual.

Installation of the Chute

⚠ WARNING: To avoid serious personal injury or death: Park the vehicle on level ground, place the transmission in neutral, set the parking brake, place all control levers in neutral, shut off the engine, remove the ignition key and allow the rotating parts to stop **BEFORE** working on the vehicle.

1. **Figure 1:** Place the rotation bushing (item 1) on the snowblower chute base (item 4).
2. **Figure 1:** Install the chute (item 2) over the rotation bushing and install the six 3/8" spacers (item 3a) and the three 11GA thin spacers (item 3b) on the chute base (item 4).
3. **Figure 1:** Apply grease under the retaining plates (items 5-6) before installation.

NOTE: Use high quality grease designated "extreme pressure" and containing molybdenum disulfide. This grease can specify "Moly EP" on its label.

4. **Figure 1:** Attach the two retaining plates with 3 holes (items 5) by placing the 2 holes section toward the plate of the rotation support with six 1/2" x 2" carriage bolts, six 1/2" lockwashers and six 1/2" hex nuts (items 6-7-8).
5. Tighten all bolts according to the **Torque Specification Table** at the end of the manual.

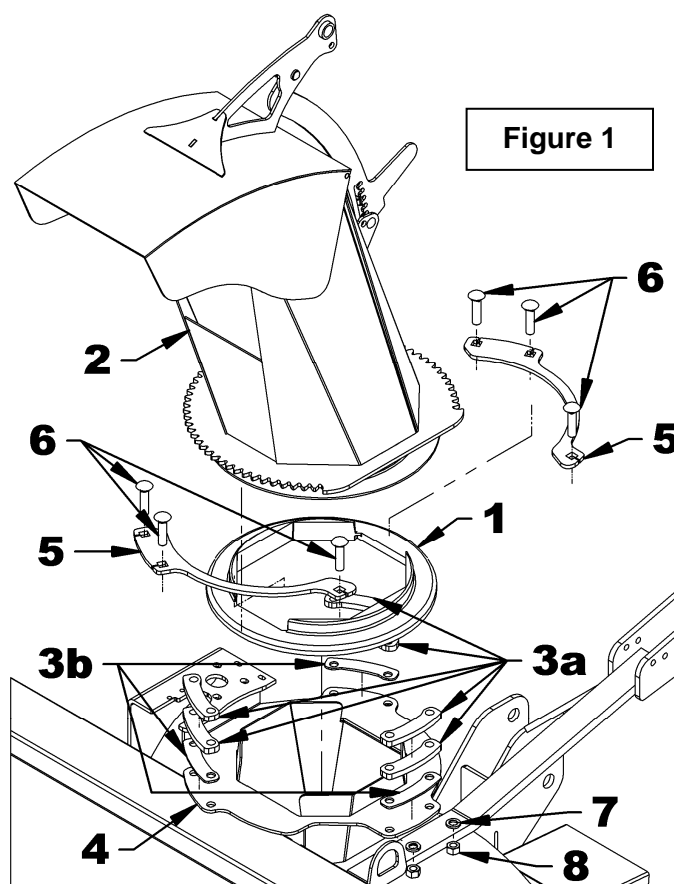

ASSEMBLY

Snowblower Installation with a 3-Point Hitch

1. **Figure 2:** Make sure the parking stand is lowered. To do this, remove the round wire lock pin (item 9) from the parking stand (item 8), lower the parking stand and insert the round wire lock pin (item 9) under the snowblower attachment tube.

2. **Figure 2: Category 1** - Attach the tractor lower arms (item 2) with the two pins (item 1) and secure with the 7/16" linchpins (item 3) in the lower holes (item 4).

Figure 2: Category 2 – Insert the 1 1/8" x 2 1/2" bushing (item 10) in each tractor lower arms (item 2). Then, attach the tractor lower arms in the lower holes of the snowblower (item 4) with a pin (item 1) and secure with a 7/16" linchpin (item 3).

3. **Figure 2: Category 1** - Attach the tractor upper arm (item 5) between the plates of the snowblower upper hitch (item 7) with the pin and the linchpin (item 6) provided with the tractor.

Figure 2: Category 2 – Insert a 1" x 1 3/4" bushing (item 11) in the upper arm of the tractor (item 5). Then attach the upper arm of the tractor between the plates of the snowblower upper hitch (item 7) with the pin and the linchpin (item 6) provided with the tractor.

4. **Figure 2:** Adjust the snowblower using the upper arm of the tractor (item 5) so that the snowblower is perpendicular to the ground.

5. **Figure 2:** Adjust the anti-sway arms of the tractor to prevent lateral swinging of the snowblower. Make sure there is no contact with the tires.

6. **Figure 2:** Raise the parking stand. To do this, remove the round wire lock pin (item 9) from the parking stand (item 8), raise the parking stand and insert the round wire lock pin (item 9) over the snowblower attachment tube.

7. Go to "**Preparation of the Driveline**" section for further installation of the blower.

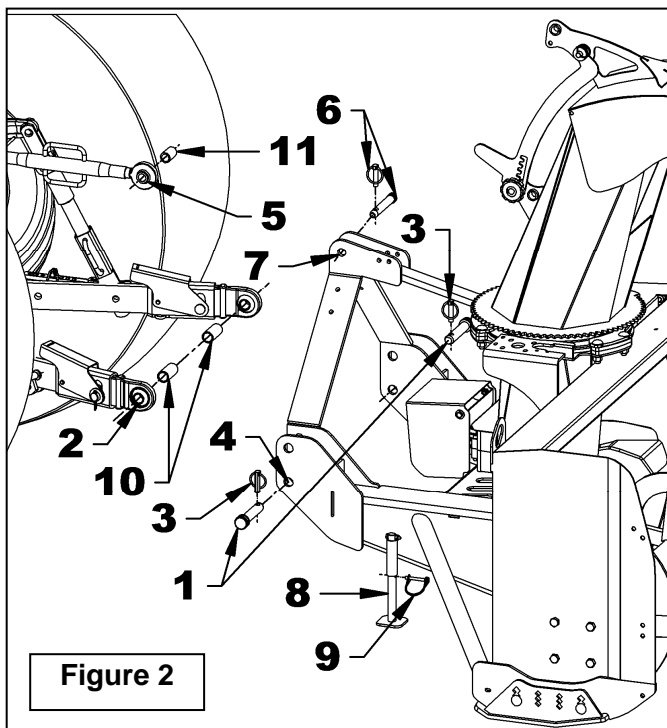

CAUTION

Before connecting snowblower driveline to tractor drive shaft, make sure driveline is not too long in raised, lowered and middle position. If the driveline is too long it must be shortened, to avoid damaged to tractor. See pages 17 and 18 for instructions.

ASSEMBLY

Snowblower Installation with a Quick Hitch (Category 1 only)

NOTE : For the installation of the snowblower with a Quick Hitch, two 1 1/2" x 2 1/8" bushings (668059) (item 10) and one 1 1/4" x 1 7/8" bushing (668058) (item 11) are required, but they are not supplied with the snowblower.

- 1. Figure 3:** Make sure the parking stand is lowered. To do this, remove the round wire lock pin (item 9) from the parking stand (item 8), lower the parking stand and insert the round wire lock pin (item 9) under the snowblower attachment tube.
- 2. Figure 3:** Insert a 1 1/2" x 2 1/8" bushing (item 10) between the plates of the snowblower lower hitch and secure in the upper hole (item 4) with the pin (item 1) and the 7/16" linchpin (item 3). Do the same on the other side.
- 3. Figure 3:** Insert a 1 1/4" x 1 7/8" bushing (item 11) between the plates of the snowblower upper hitch (item 7) and secure with the pin and the linchpin (item 6) provided with the tractor.

- 4. Figure 3:** Make sure that the quick release latches (item 2) are securely closed. Lower the 3-Point so that the hooks on the quick hitch (item 2) are lower than the snowblower pins and bushings (items 1 and 10). Reverse the tractor slowly until the hooks are under snowblower pins and bushings (items 1 and 10). Then, raise the 3-Point until the quick-release latches (item 2) snap on the pins with the snowblower bushings (items 1 and 10) to lock the system.
- 5. Figure 3:** Adjust the snowblower using the upper arm of the tractor (item 5) so that the snowblower is perpendicular to the ground.
- 6. Figure 3:** Raise the parking stand. To do this, remove the round wire lock pin (item 9) from the parking stand (item 8), raise the parking stand and insert the round wire lock pin (item 9) over the snowblower attachment tube.
- 7. Go to " *Preparation of the Driveline* " section for further installation of the blower.**

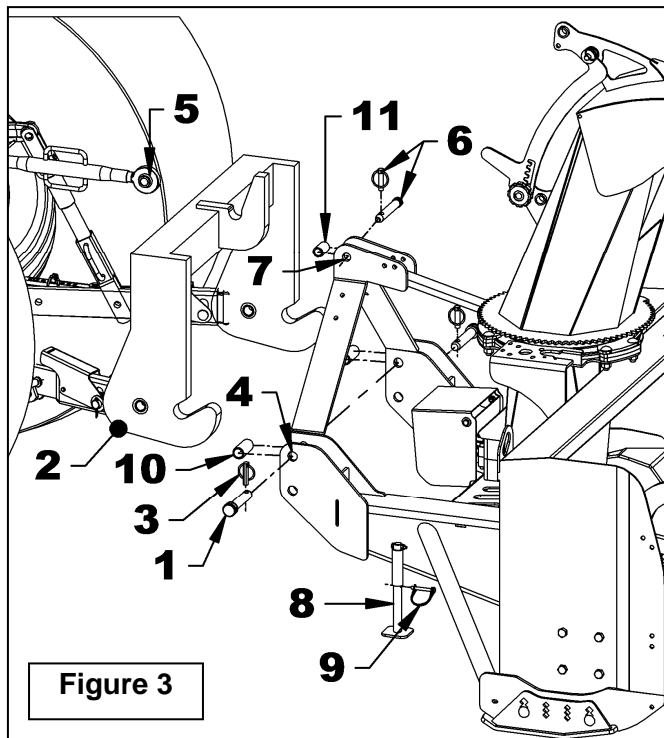

Figure 3



CAUTION

Before connecting snowblower driveline to tractor drive shaft, make sure driveline is not too long in raised, lowered and middle position. If the driveline is too long it must be shortened, to avoid damaged to tractor. See pages 17 and 18 for instructions.

ASSEMBLY

PREPARATION OF THE DRIVELINE

Recommendations for Driveline Angles

IMPORTANT: To obtain the proper universal joint angles, it is recommended to adjust the 3-Point hitch at the furthest point from the tractor recommended by the manufacturer.

The universal joint angle is directly related with the life of driveline. To reduce the angle, it is necessary to increase the distance between the snowblower and the tractor.

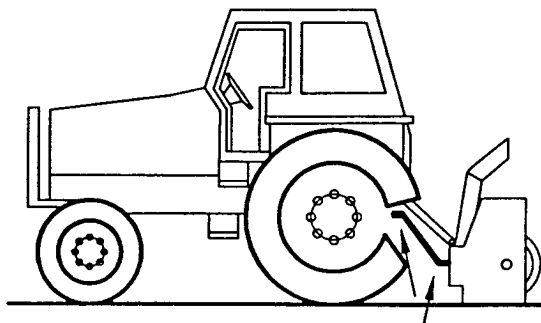

Angles of Driveline Joints Too Large
Avoid

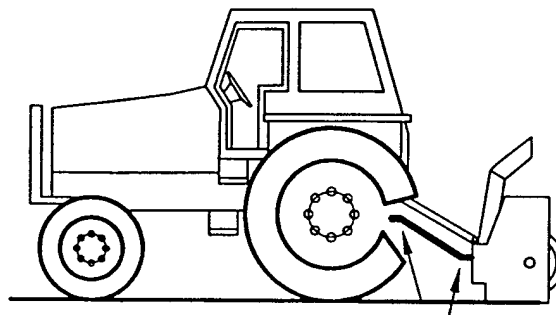

Reasonable Angles of Driveline Joints
Acceptable

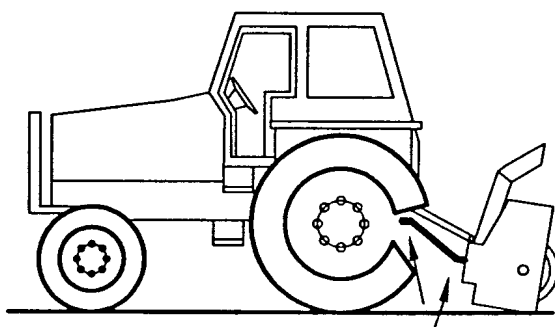

Unequal Angles at Driveline Joints
Avoid

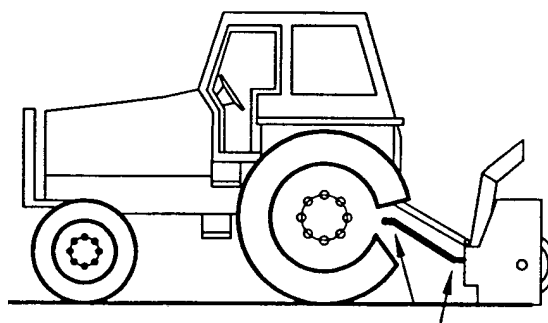

Equal Angles at Driveline Joints
Recommended

Angles at Each End of Driveline

A popular habit is to change the snowblower angle to obtain a better scraping effect. This practice can become harmful to the driveline since the angle at each end is unequal. This results in a fan speed variation as well as a drastic increase of load on cross and bearings. To be avoided: It is recommended to always keep tractor driveline and snowblower input shaft parallel.

ASSEMBLY

Determining Driveline Length

IMPORTANT: Before using the equipment, make sure the driveline is not too long. At working, the two half drivelines must intersect each other sufficiently to insure maximum efficiency but there must not be any interference.

1. **Figure 4:** To determine the "L" length for your tractor model first find the "X" factor by measuring the horizontal distance between the end of the tractor's drive shaft and the end of the snowblower's driven shaft when the snowblower is in transport position as shown in figure.

2. Choose in the table below the "Y" factor according to the driveline series and deduct that number from "X" measured previously to determine "L" (fig.7) which is the center-to-center length between the universal joints.

NOTE : The driveline series is inscribed on the plastics guards.

$L = X - Y$		
DRIVELINE SERIES	Y	MINIMUM CROSSING
20 Series	4 1/2"	5 1/4"
40 and 50 Series	5 1/2"	7 1/2"

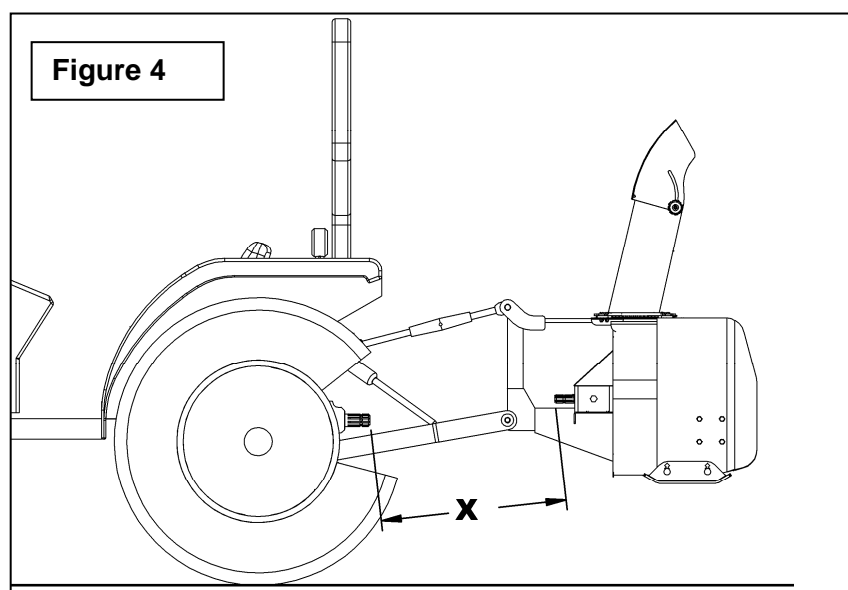

ASSEMBLY

3. **Figure 5:** Hold the two half-shaft side by side and locate the "L" length between the two center-to-center half-shaft universal joints. Mark off the zone to be cut on both halves opposite each half-shaft guard as shown in figure.

4. **Figure 5A:** Cut off inner and outer guard tubes as well as the inner and outer telescopic sections.

5. **Figure 5A:** Cut the guard a second time leaving the same distance between the end of the guard and the end of the shaft as existed before. To obtain the proper distance "A" shown in figure, cut the guard according to the following table:

DISTANCE A	
Male PTO	Female PTO
1 3/4"	1 1/4"

6. **Figure 5A:** File down tubes and remove chips.

7. Apply grease to inside of outer telescopic section.

IMPORTANT: Work with fully guarded shafts only!

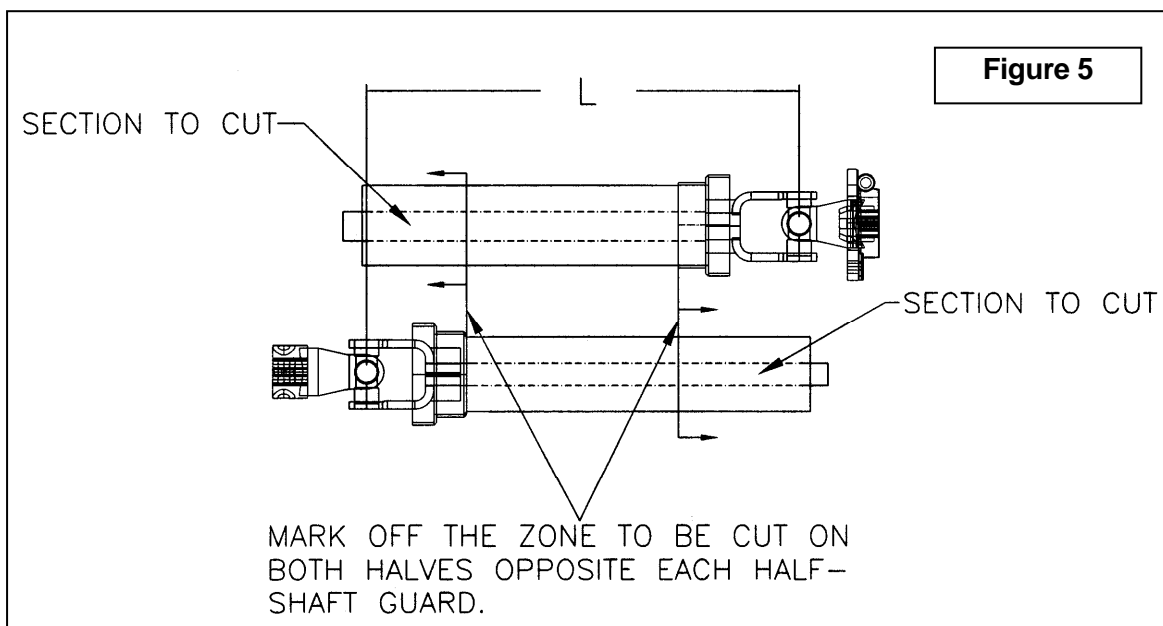
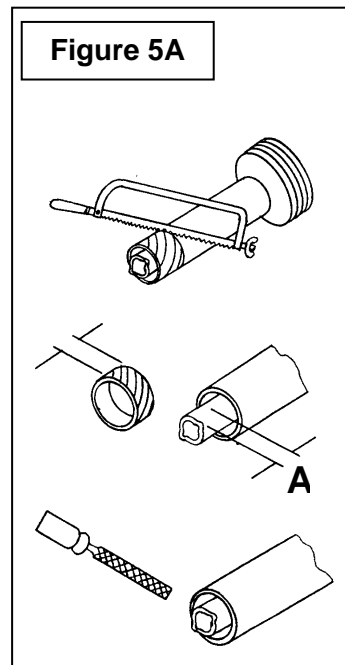

ASSEMBLY

Driveline Installation

1. **Figure 6:** Remove the paint from the gearbox shaft (item 1) and grease if needed. Grease also the sliding surfaces and yoke (item 2) of the driveline.
2. **Figure 6:** Remove the bolts (item 3) from the yoke (item 2) and connect the yoke to the gearbox shaft (item 1). Secure the driveline by reinstalling the bolts and nuts (items 3-4) in the order shown. Tighten all bolts according to the **Torque Specification Table** at the end of the manual.
3. **Figure 6:** Install the driveline (item 5) on the tractor shaft.
4. **Figure 6:** Attach the safety chain (item 5), snowblower side, around the right or left hitch to prevent driveline shield from rotating. Attach the safety chain, tractor side, to the tractor appropriate location.



To avoid serious injuries or death: This shaft rotates at high revolution (RPM). If the quick release system is not securely locked on the tractor shaft (a click must be heard) or if the coupling to the snowblower is not secured correctly, the driveline can be released with force which can cause serious injury or death.

Figure 6

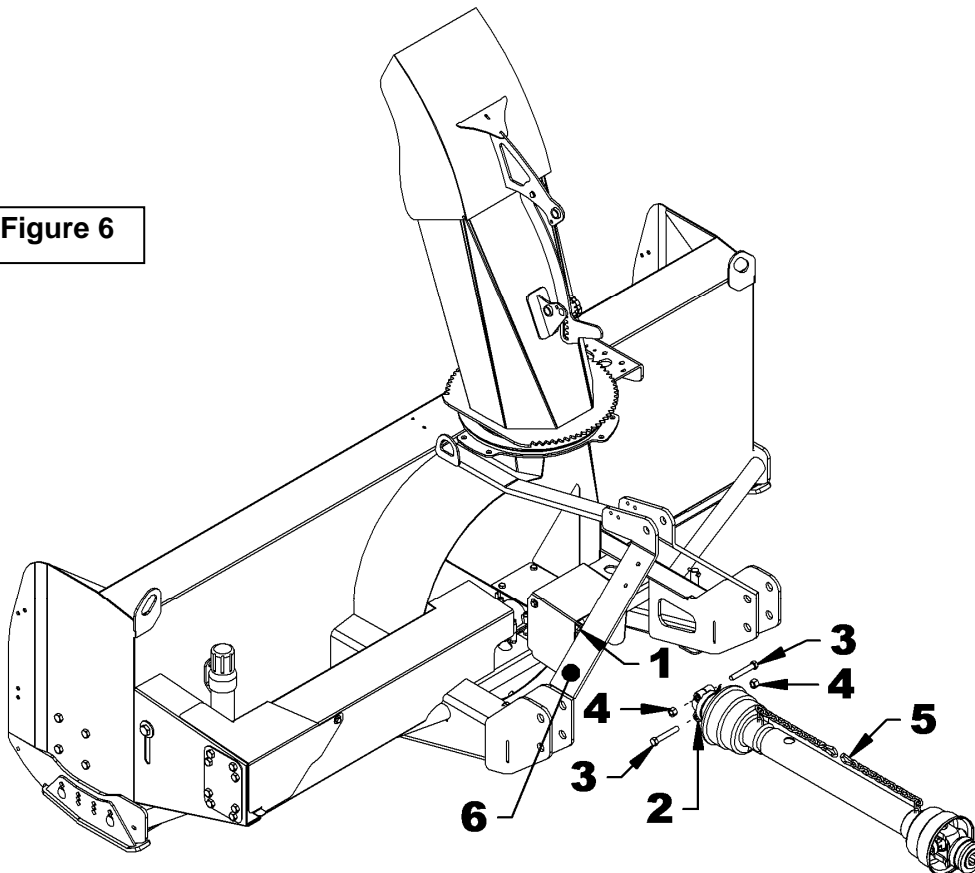

ASSEMBLY

Remove the Snowblower from the Tractor



WARNING: To avoid serious personal injury or death: Park the vehicle on level ground, place the transmission in neutral, set the parking brake, place all control levers in neutral, shut off the engine, remove the ignition key and allow the rotating parts to stop **BEFORE** working on the vehicle.

With 3-Point Hitch

1. **Figure 7:** Lower the parking stand. To do this, remove the round wire lock pin (item 8) from the parking stand (item 7), lower the parking stand and insert the round wire lock pin (item 9) under the snowblower attachment tube.
2. **Figure 7:** Detach the upper arm (item 4) by removing the linchpin and the pin (items 5). Remove the bushing (item 9) if category 2.
3. **Figure 7:** Detach the driveline from the tractor and attach the safety chain to the snowblower for storage.
4. **Figure 7:** Detach the lower arms (item 2) by removing the linchpins (items 3) and the hitch pins (item 1). Remove the bushings (items 10) if category 2. Loosen the anti-sway arms and slowly advance the tractor.

With Quick Hitch

1. **Figure 7:** Lower the parking stand. To do this, remove the round wire lock pin (item 8) from the parking stand (item 7), lower the parking stand and insert the round wire lock pin (item 9) under the snowblower attachment tube.
2. Detach the driveline from the tractor and attach the safety chain to the snowblower for storage.
3. Make sure the quick release latches are fully open. Lower the 3-Point so that the hooks on the quick-hitch are lower than the pins and the snowblower bushings. Move the tractor slowly.
4. Close the quick release latches of the quick hitch.

IMPORTANT: To avoid damaging the snowblower, tighten all the bolts after the first 10 hours of operation.

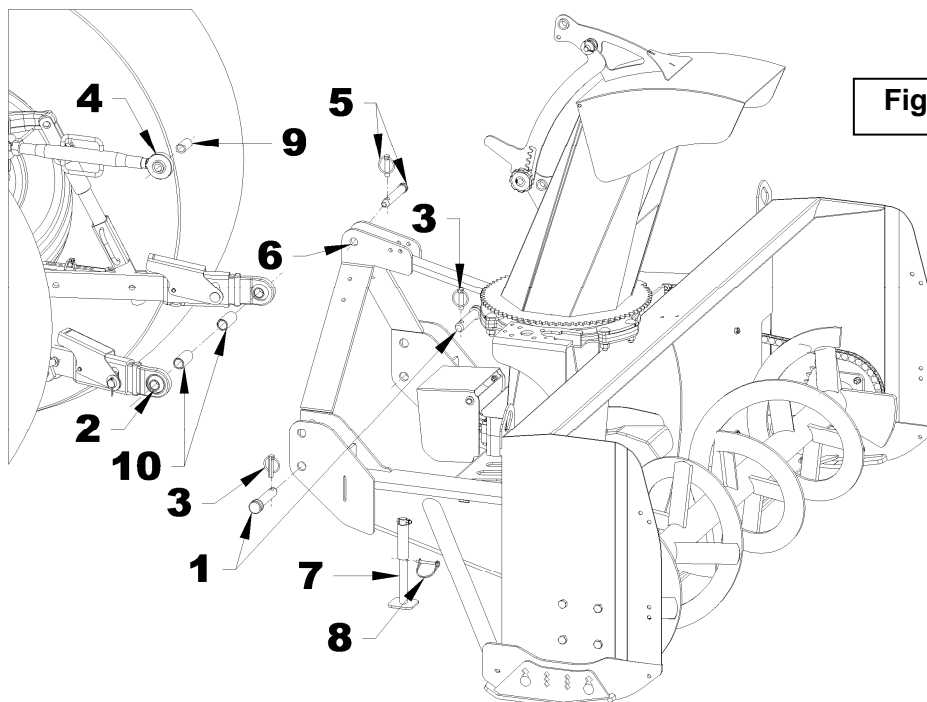

OPERATION

GENERAL PREPARATION

1. Read the operator's manual carefully before using the tractor and snowblower. Be thoroughly familiar with the controls and proper use of the equipment. Know how to stop the unit and disengage the controls quickly.
2. Wear adequate winter outer garments while operating the equipment.
3. Make sure the snowblower is clear of snow and other material before engaging the snowblower.
4. Make sure the auger and fan operate freely.
5. Check the oil level in the reduction box and if necessary, add AGMA 5EP, SAE 80W90 gear oil or equivalent.
6. Check the three shear bolts, one on each auger section and one between the fan and gearbox for proper tightness.
7. Adjust the skid shoes so the snowblower runs leveled.
8. Make sure the parking stand is in the raised position.

CONTROLS

Up and Down Control

Use the control lever of the 3-Point hitch. RAISE the snowblower by pulling on the lever and LOWER by pushing on the valve lever.

Work and Travel Speed

Travel speed will depend on the depth and density of the snow to be cleared. Normally, ground speed will range from 4 to 7 mph for light, dry snowfalls from 3" to 6", and from 1 to 3 mph for heavy, wet or drifted snow. To move, disengage the PTO and raise the snowblower to its maximum height.

Engaging the Drive Mechanism

Refer to the tractor's operating manual for instructions.

Manual Rotation - Option

If this blower is equipped with a manual chute rotation, the orientation of the chute must be adjusted so that the snow is projected at the desired location. To adjust the orientation of the chute, turn the handle clockwise to orient the chute to the right of the snowblower

Hydraulic Rotation - Option

If this snowblower is equipped with an optional hydraulic chute rotation by motor, the motor is equipped with flow restrictors which limit the speed of the chute rotation. Ensure that the hoses are connected to the hydraulic outputs of the tractor. Activate the appropriate tractor controls to activate the appropriate outputs and thereby activate the chute rotation. Reverse hoses if the rotation is not in the desired direction.

OPERATION

Manual Deflector

If this snowblower is equipped with an original manual deflector, the angle of the deflector must be adjusted so that the snow is projected at the correct distance. To adjust the deflector angle, unscrew the plastic handle and select a notch at the desired angle. It is recommended to use the notches, but it is possible to adjust the angle between two notches. Tighten the plastic handle.

Hydraulic Deflector - Option

If this snowblower is equipped with a hydraulic deflector. Ensure that the hoses are connected to the hydraulic outputs of the tractor. Activate the appropriate tractor controls to activate the appropriate outputs and activate the deflector. Reverse hoses if movement of the fall output is not in the desired direction.

Electric Deflector - Option

If this blower is equipped with an electric deflector, make sure the harness is properly connected to the harnesses installed on the tractor. Operate the switch to activate the deflector.

OPERATION

ADJUSTMENTS

⚠ WARNING

To avoid serious personal injury or death: Make sure tractor engine and snowblower come to a complete stop and tractor drive mechanism is disengaged BEFORE making any adjustments.

Skid Shoes Adjustment (Figure 8)

Adjust the snowblower so that the skid shoes run level and according to the surface conditions so that stones are not thrown with the snow. Make sure the skid shoes are at the same height to keep cutting edge leveled.

To adjust the skid shoes, remove the bolts (item 2) and reinsert them in the appropriate hole according to the following settings:

Clearance between cutting edge and surface:

- **Level paved surface:**
In the lower holes.
- **Uneven or gravel surface:**
In the middle or upper holes.

Drive Chain Tension Adjustment (Figure 8)

IMPORTANT: A tension too tight can cause premature wear of the chain. It is important not to tighten the chain to its maximum

Adjust the chain according to the following steps:

- Loosen the bolt (item 1) securing the idler sprocket to the snowblower.
- Adjust the bolt height to obtain a deflection of 1/8" in one chain length.
- Securely tighten the bolt (item 1) securing the idler sprocket.

Unclog the Chute (Figure 9)

If the chute (item 1) is blocked, it is possible to use the adjustment arm (item 2a) of the chute. Unscrew the plastic handle completely (item 3) and remove the adjustment arm end. Reinstall the plastic handle. Remove the circle cutter and the flat washer (item 4) and then remove completely the adjustment arm. Use the deflector attachment section (item 5) to unblock the item (item 1) and the handle (item 6) to hold the adjustment arm (item 2b) by rotating to pass through snow and thus unblock the chute. Reinstall the adjustment arm once the chute is unlocked.

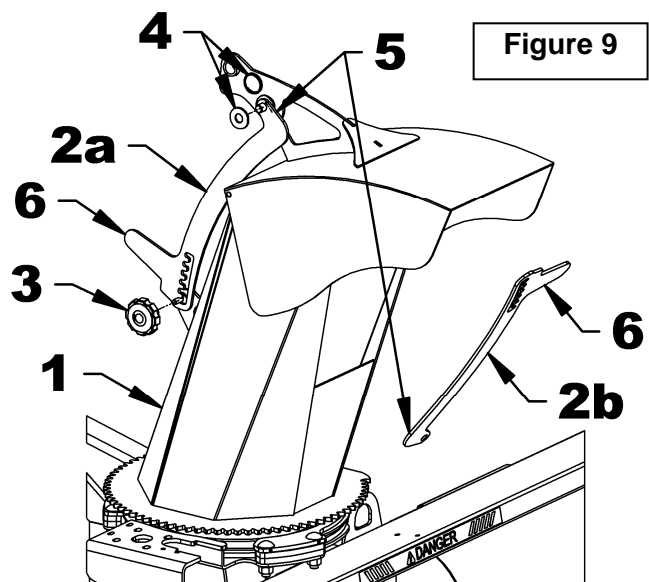
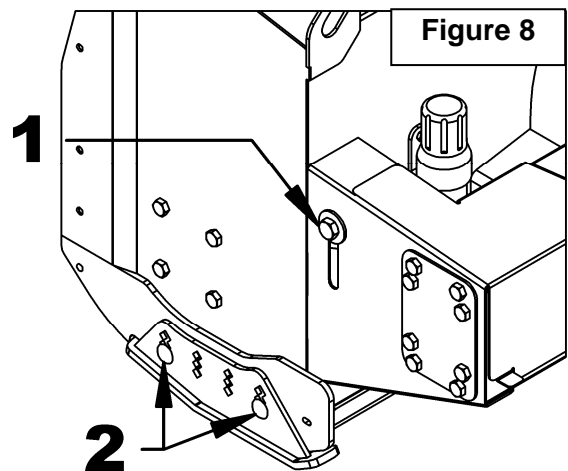

OPERATION

SNOW REMOVAL METHODS

When removing snow, do not use the snowblower as a dozer blade to push snow. Let the snowblower work its way through deep drifts. If the speed of your tractor is too fast, the snowblower may become overloaded and clog. For best results, raise the snowblower and remove a top layer of snow. A second pass with the snowblower will remove the remaining snow.

IMPORTANT: Use full RPM power when removing wet, sticky snow. Low RPM power will tend to clog the chute.

⚠ WARNING: Do not use hands or feet to unclog chute. Do not attempt to clear clogged chute of snow while tractor engine is running. If the chute clogs, disengage the PTO according to owner's manual, shut off the tractor engine, remove the ignition key, wait for all movement to stop, and then clear the snow from the chute.

A definite pattern of operation is required to thoroughly clean the snow area. These patterns will avoid throwing snow in unwanted places as well as eliminating a need to perform a second pass with the snowblower.

PATTERN 1

DISCHARGE SNOW BOTH SIDES

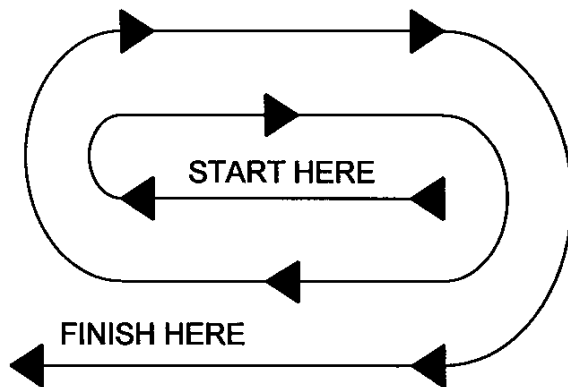

DISCHARGE SNOW BOTH SIDES

Where it is possible to throw the snow to the left and right (above), as on a long driveway, it is advantageous to start in the middle. Plow from one end to the other, throwing snow to both sides without changing the direction of the chute.

PATTERN 2

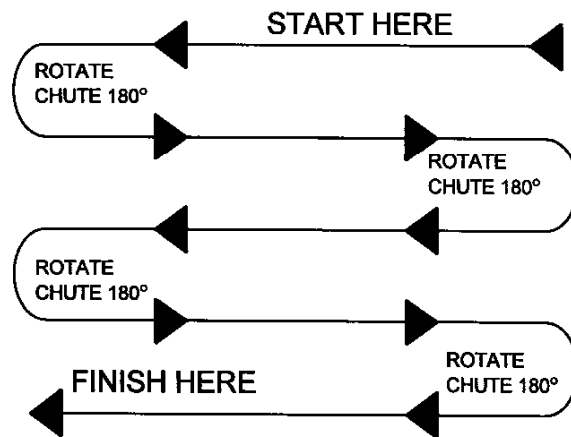

DISCHARGE SNOW THIS SIDE ONLY

If the snow can only be thrown to one side of the driveway or sidewalk (above), start on the opposite side. At the end of the first pass, rotate the discharge guide 180 degrees for the return pass. At the end of each succeeding pass, rotate the chute 180 degrees to maintain direction of throw in the same area.

MAINTENANCE

MAINTENANCE

ALWAYS USE GENUINE PARTS WHEN REPLACEMENT PARTS ARE REQUIRED

1. Keep the tractor and snowblower properly maintained.
2. Park the tractor/snowblower on level ground, place the transmission in neutral, set the parking brake, disengage the PTO, lower the snowblower to the ground, place all control levers in neutral, shut off the engine and remove the ignition key and allow the rotating parts to stop **BEFORE** making any snowblower adjustments.
3. To avoid injury, do not adjust, unblock the driving system, or service the snowblower with the tractor engine running.
4. Keep the tractor/snowblower clean. Snow, dirt or ice build-up can lead to malfunction or personal injury from thawing and refreezing in garage.
5. Always wear eye protection when cleaning or servicing the snowblower or subframe.
6. **DO NOT** service the tractor while the engine is running or hot, or if the unit is in motion. Always lower snowblower to the ground. If necessary to service snowblower in raised position, securely support with stands or suitable blocking before working underneath. Do not rely on hydraulically supported devices for your safety. They can settle suddenly, leak down, or be accidentally lowered
7. Do not attempt to service machine, clear obstructions or unclog the snowblower with the engine running. Always shut off engine and allow all motion to cease.
8. The manufacturer will not claim responsibility for fitment of unapproved parts and/or accessories and any damages because of their use.
9. Make sure all shields and guards are securely in place following all service, cleaning, or repair work.
10. Do not modify or alter this snowblower or any of its components or operating functions. If you have questions concerning modifications, consult with your dealer.
11. Do not operate a snowblower that is defective or has missing parts. Make sure that all recommended maintenance procedures are completed before operating the snowblower.
12. Check all controls regularly and adjust where necessary. Make sure that the brakes are evenly adjusted.
13. Periodically check all nuts and bolts for tightness, especially wheel hub and rim nuts.
14. A hydraulic/diesel fluid that escapes under pressure can penetrate the skin and cause severe injury. Do not use hands to look for a leak, use a piece of paper or cardboard. If liquid is injected into the skin, seek immediate medical attention.
15. Stop the engine and remove pressure before connecting or disconnecting the hydraulic hoses. Tighten all connections before starting the engine or putting pressure back into the hoses.

MAINTENANCE

⚠ To avoid serious personal injury or death: Provide adequate blocking before working under the snowblower when in raised position

MAINTENANCE SCHEDULE		
DESCRIPTION	INTERVAL	REQUIRED MAINTENANCE
Hardware	After the first 8 hours of operation	Tighten all nuts and bolts according to <i>the Torque Specification Table</i> .
	40 hours of operation	
Connection points Hydraulic/Electric	Before each equipment connection	Visual inspection of the connectors hydraulic/electric. Clean if necessary.
Shearbolts	As needed	See Table and the figure below
Lubrication	See Table next page	See Table next page

Shearbolts

At regular intervals, check the tightening of the shearbolts shown in the figure below to ensure proper operation of the snowblower. To access the shearbolts (items 1 and 2), lift the guards (items 3 and 4). If the bolts need to be replaced, use the following parts only:

	B84C-L
Driveline (item 1)	657199
Drive shaft (item 2)	669596

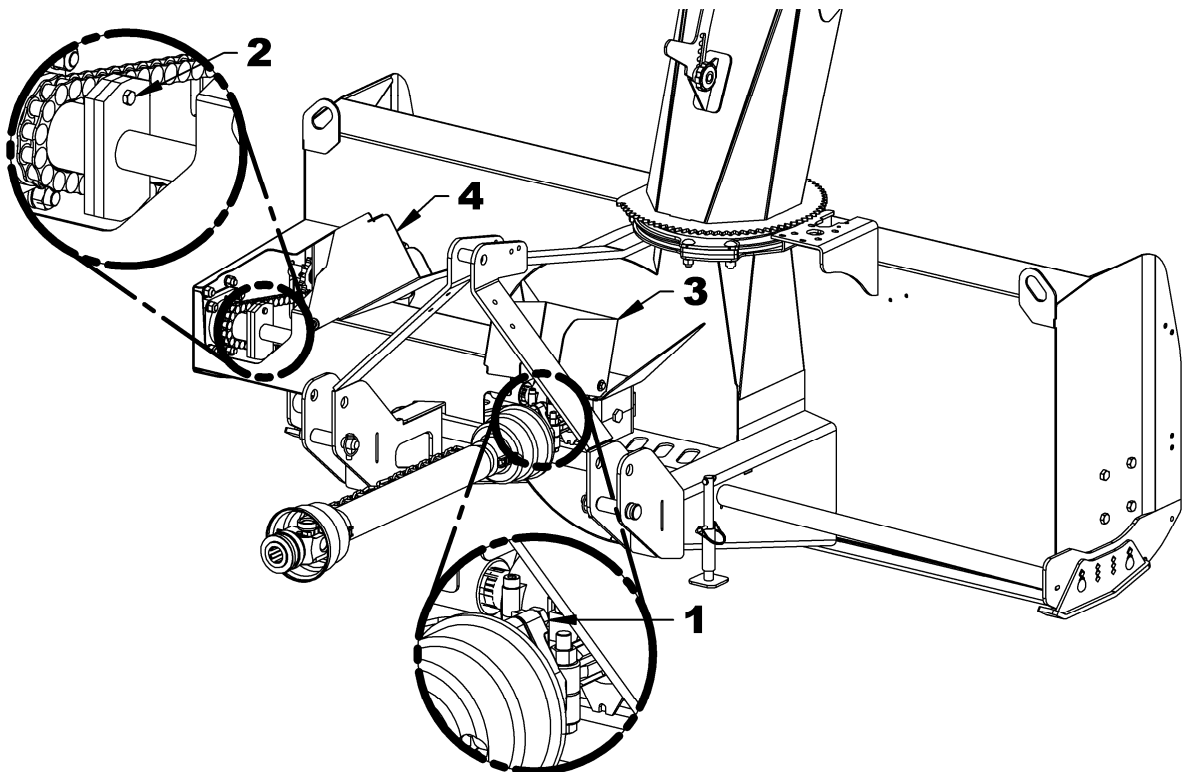

MAINTENANCE

LUBRICATION

Use a grease gun and lubricate as follows:

DESCRIPTION	INTERVAL	REQUIRED LUBRICATION
Gearbox	Monthly	Check oil level. If needed, add extreme pressure oil, SAE 80W90 gear oil or equivalent.
	Once a year	Replace oil
Drive chain	4 hours and after each operation	Lubricate with chain saw lubricant.
Drive shaft	24 hours of operation	Grease at the shear plate and the grooved section with the grease fittings. Use a Shell Gadus S5 V100 grease or equivalent.
Bearings	24 hours of operation	Grease each auger and drive shaft bearings. Use a Shell Gadus S5 V100 grease or equivalent.
Driveline	8 hours	Grease each universal joint. Separate the sliding parts and cover each with grease.
	16 hours	Oil the quick connect yokes.

IMPORTANT: Perform all the maintenance section without taking into account the hours given in the following cases:

- At least once a year if the snowblower is used less than 20 hours annually.
- After each storage period.
- After each wash.

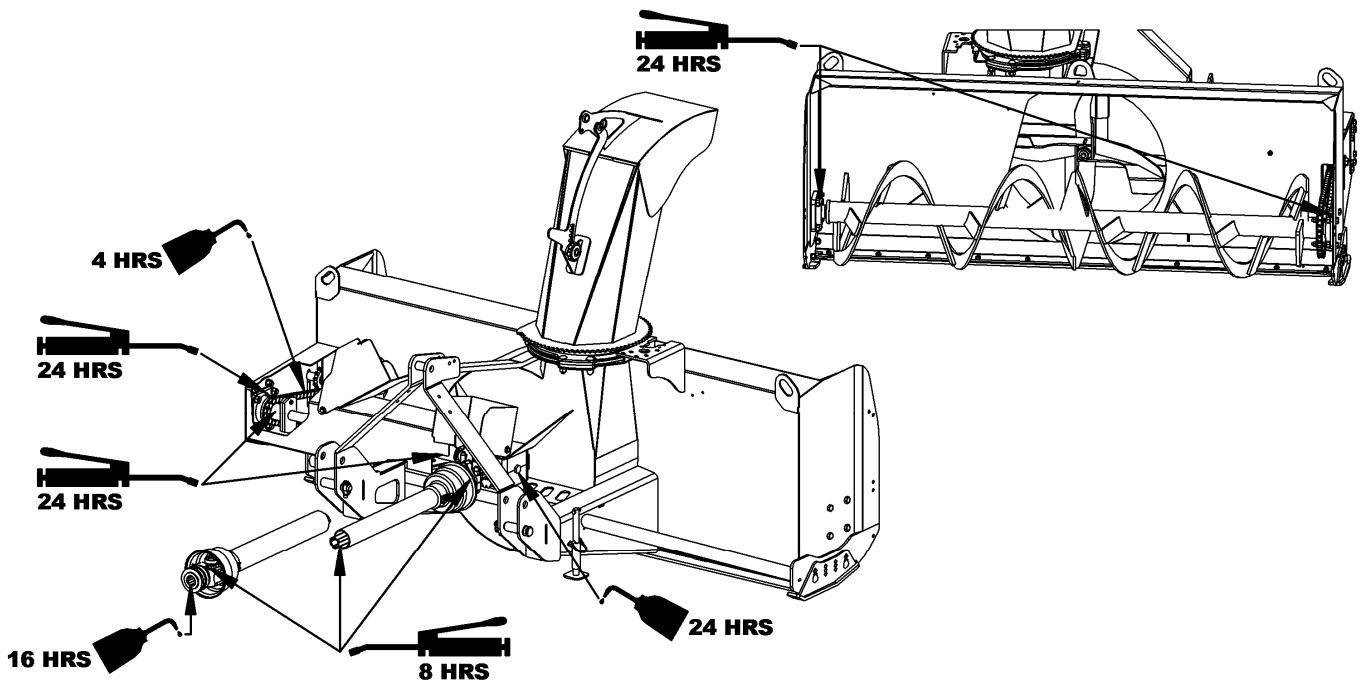

MAINTENANCE



WARNING

To avoid serious personal injury:

- Before cleaning, adjusting or repairing the snowblower: bring the tractor to a complete stop, lower the implement shut off the engine and remove the ignition key.
- Never park the tractor inside a building where an open flame or sparks are present. Allow the engine to cool down before storing in any enclosure.
- Run the snowblower a few minutes after blowing snow to prevent freeze up of auger and fan.
- Always remove the snowblower from the subframe if you need to work on the snowblower.

GEARBOX

Oil Level – Oil Fill Up

To check oil level.

1. Remove oil level plug.
2. If the oil is not flush with the plug, fill until the oil SAE 80W90, the AGMA 5EP extreme pressure or equivalent flows through the oil level plug hole.
3. Reinstall the plug.

Oil Change

1. Remove oil filler plug.
2. Remove oil change plug and let oil flow through until only small drops are coming out.
3. Fill gearbox/ reduction box with SAE 80W90 oil, AGMA 5EP extreme pressure oil or equivalent, until oil reaches oil level plug. Reinstall oil level plug, then oil filler plug.

NOTE: When the gearbox is opened, the seal must be re-established. To do this, apply a layer of silicone to the surface of the casing before closing it. Allow the silicone to dry for at least 24 hours before filling with oil.

TROUBLESHOOTING

PROBLEM	CORRECTIVE MEASURES
1. Auger and fan not turning	<ul style="list-style-type: none"> • Check if an object is blocking the auger or fan • Check that PTO is engaged • Check that the drive system is in the engaged position • Check if chain is broken • Check if shearbolts are broken and replace if necessary • Gearbox lacking oil and is seized. Replace gearbox.
2. Snow is not being ejected from the chute	<ul style="list-style-type: none"> • Check if the fan is turning, refer to problem # 1 • Check if the snow output is obstructed, unclog with a 36" stick
3. Snowblower clogs up easily	<ul style="list-style-type: none"> • Engine is not at full RPM • Check that the chute is not obstructed • Reduce travel speed
4. Snow doesn't enter the snowblower properly	<ul style="list-style-type: none"> • Engine is not at full RPM • Check if shearbolts are broken and replace if necessary • Check auger positions. (refer to section Operation)
5. Snow is not thrown very far	<ul style="list-style-type: none"> • Engine is not at full RPM • Reduce travel speed • Check that the chute is not obstructed

TROUBLESHOOTING

DRIVELINE TROUBLESHOOTING

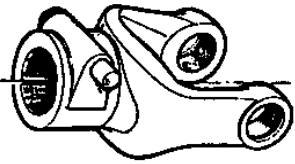
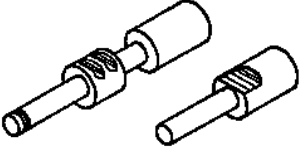
	AVOIDABLE DAMAGES	POSSIBLE CAUSES	CORRECTIVE ACTIONS
<p>QUICK-DISCONNECT YOKE</p> 	<p>1. ♦ Quick-disconnect pin tight or completely seized.</p> <p>♦ Quick-disconnect pin damaged (broken or bent)</p> <p>♦ Quick-disconnect pin damaged in the locking portion.</p> 	<p>♦ Quick-disconnect pin dirty (insufficient maintenance).</p> <p>♦ Quick-disconnect pin defective (forced engagement, incorrect handling)</p> <p>♦ Excessive shaft length.</p> <p>♦ Axial loads too high.</p>	<p>♦ Clean, oil and follow service instructions.</p> <p>♦ Replace quick-disconnect pin.</p> <p>♦ Shorten shaft length (cut both telescopic tubes as well as shield and remove burrs).</p> <p>♦ Replace quick-disconnect pin.</p> <p>♦ Clean and grease telescopic tubes, and replace both tubes, if necessary.</p> <p>♦ Replace quick-disconnect pin.</p>



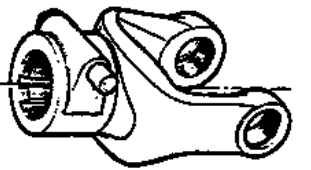
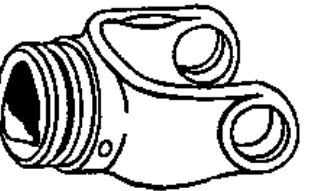
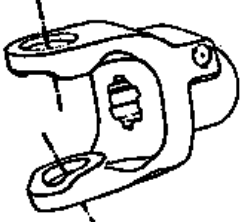
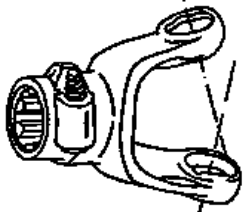
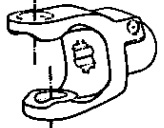
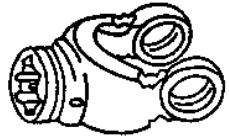

Note: Quick-disconnect pins must be cleaned and greased every 16 hours.

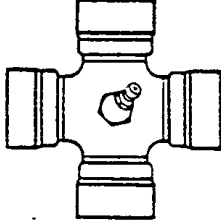
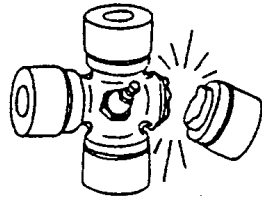
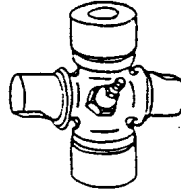
	AVOIDABLE DAMAGES	POSSIBLE CAUSES	CORRECTIVE ACTIONS
<p>YOKE</p>   	<p>♦ Yoke ears deformation</p>  	<p>♦ Excessive shaft length.</p> <p>♦ Axial loads too high.</p> <p>♦ Excessive working angle and torque.</p>	<p>♦ Shorten shaft length (cut both telescopic tubes as well as shields and remove burrs).</p> <p>♦ Replace defective yokes.</p> <p>♦ Clean and grease telescopic tubes, and replace both tubes, if necessary.</p> <p>♦ Replace defective yokes.</p> <p>♦ Verify compatibility between shaft and working conditions (torque vs. angle).</p> <p>♦ Disengage tractor driveline during cornering or when lifting or lowering the implement.</p> <p>♦ Change to a larger driveline size.</p> <p>♦ Replace defective yokes.</p>
	<p>♦ Yoke ears distorted.</p> 	<p>♦ Overload caused by high starting and peak torques.</p>	<p>♦ Engage driveline more carefully.</p> <p>♦ Use appropriate safety devices.</p> <p>♦ Replace defective yokes.</p>
	<p>Yoke ears worn or pounded.</p> 	<p>♦ Excessive working angle.</p>	<p>♦ Avoid excessive working angle.</p> <p>♦ Disengage tractor driveline during cornering.</p> <p>♦ Replace defective yokes.</p>

TROUBLESHOOTING

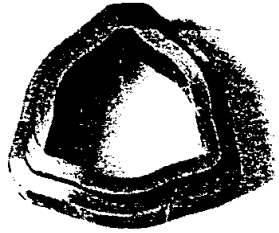
	AVOIDABLE DAMAGES	POSSIBLE CAUSES	CORRECTIVE ACTIONS
<p>CROSS KIT</p> 	<ul style="list-style-type: none"> ♦ Cross arms broken. 	<ul style="list-style-type: none"> ♦ Extreme torque peak or shock load. ♦ Axial loads too high. 	<ul style="list-style-type: none"> ♦ Use appropriate safety device. ♦ Change to a larger driveline size. ♦ Shorten driveline shaft. ♦ Replace defective cross bearings.
	<ul style="list-style-type: none"> ♦ Bearing caps turning in their cross journal. ♦ Overheated bearing caps. 	<ul style="list-style-type: none"> ♦ Excessive continuous torque and/or excessive working angle. ♦ Inadequate greasing. 	<ul style="list-style-type: none"> ♦ Verify compatibility between shaft and working conditions. ♦ Carefully follow greasing instructions. ♦ Replace defective cross bearings.
	<ul style="list-style-type: none"> ♦ Accelerated wear of cross kit. 	<ul style="list-style-type: none"> ♦ Excessive continuous torque and/or excessive working angle. ♦ Inadequate greasing. 	<ul style="list-style-type: none"> ♦ Verify compatibility between shaft and working conditions. ♦ Carefully follow greasing instructions. ♦ Replace defective cross bearings.

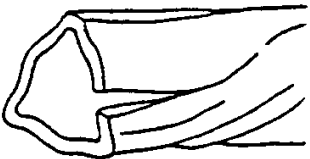
Note: Cross bearings must be greased every 8 working hours.

	AVOIDABLE DAMAGES	POSSIBLE CAUSES	CORRECTIVE ACTIONS
<p>TELESCOPIC TUBES</p>  	<ul style="list-style-type: none"> ♦ Telescopic tubes failure or twisting. 	<ul style="list-style-type: none"> ♦ Extreme torque peak or shock load. ♦ Short tube engagement. 	<ul style="list-style-type: none"> ♦ Use appropriate safety device. ♦ Change to a larger driveline size. ♦ Replace the driveline drive shaft with one having adequate length. ♦ Replace defective tubes.
	<ul style="list-style-type: none"> ♦ Accelerated wear of telescopic tubes. 	<ul style="list-style-type: none"> ♦ Extreme load when sliding. ♦ Short tube engagement. ♦ Inadequate greasing. ♦ Dirt 	<ul style="list-style-type: none"> ♦ Change to a driveline with rilsan coated inner tube. ♦ Replace the driveline with one having adequate length. ♦ Carefully follow greasing instructions. ♦ Replace defective tubes.

Note: Telescopic tubes must be cleaned and greased every 8 working hours.

TROUBLESHOOTING

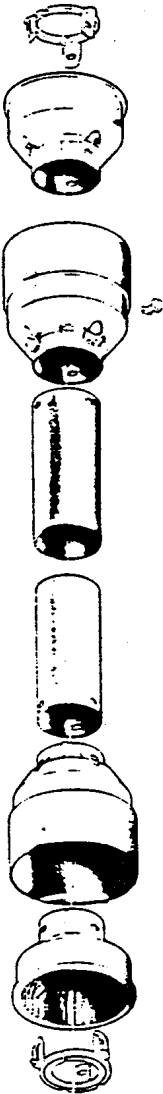
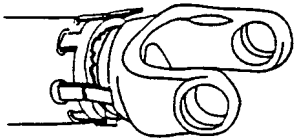
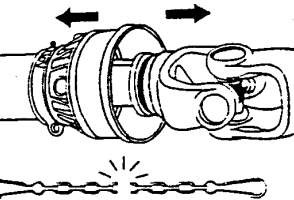
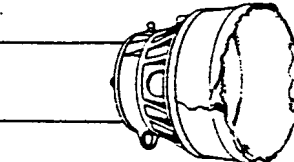
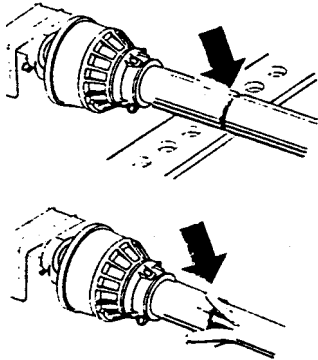
	AVOIDABLE DAMAGES	POSSIBLE CAUSES	CORRECTIVE ACTIONS
<p>SHIELD</p> 	<ul style="list-style-type: none"> Excessive wear of shield bearings. 	<ul style="list-style-type: none"> Insufficient lubrication. Incorrect chain mounting. Shield interfering with implement. 	<ul style="list-style-type: none"> Follow lubrication instructions. Mount chain to allow maximum angularity. Avoid contact of the shields with fixed parts of the machine or tractor. Replace shield bearings.
	<ul style="list-style-type: none"> Chain moving or failure. 	<ul style="list-style-type: none"> Shield interfering with implement. Incorrect chain mounting. 	<ul style="list-style-type: none"> Avoid contact of the shields with fixed parts of the machine or tractor. Mount chain to allow maximum angularity. Replace defective parts.
	<ul style="list-style-type: none"> Shield cone damaged. 	<ul style="list-style-type: none"> Shield cone in contact with components on the tractor and/or implement. Excessive angularity. 	<ul style="list-style-type: none"> Eliminate interference between Shield cones and any part on the tractor and/or implement. Avoid excessive angle during cornering or when lifting or lowering the implement. Replace damaged Shield cones.
	<ul style="list-style-type: none"> Shield tubes damaged (deformed and split at one side). 	<ul style="list-style-type: none"> Shields in contact with components on the tractor and/or implement. Shield tubes overlap too short or no overlap at all with extended driveline. 	<ul style="list-style-type: none"> Eliminate interference between Shield cones and any part on the tractor and/or implement. Replace damaged tubes. Adjust Shield tubes length with longer tubes.

Note: Shield bearings must be greased every 8 working hours.

STORAGE

STORAGE

Before storing the snowblower, certain precautions should be taken to protect it from deterioration.

1. Clean the attaching points and snowblower thoroughly.
2. Make all the necessary repairs.
3. Replace all safety signs that are damaged, lost, or otherwise become illegible. If a part to be replaced has a label on it, obtain a new safety label from your dealer and install it in the same place as on the removed part.
4. Repaint all parts from which paint has worn or peeled.
5. Lubricate the snowblower as instructed under "**Lubrication**" section.
6. When the snowblower is dry, oil all moving parts. Apply oil liberally to all surfaces to protect against rust.
7. Install the chain of the driveline shaft to support it.
8. Store in a dry place.

PARTS

SNOWBLOWER 84" - FRONT

REF.	QTY	DESCRIPTION	PART #
010	1	Housing (without gearbox)	671869
020	1	Fan 4 blades 24" CCW	671663
030	1	Auger	671860
040	1	Cutting edge	671861
050	1	Drive shaft	671862
060	1	Shear plate	669595
070	1	Oilite bushing	4300072
080	1	Shearbolt	669596
090	1	Chain #60 x 78 links (including connecting link)	654009
100	1	Connecting link #60	654839
110	1	Sprocket 60A32	654167
120	1	Idler Sprocket 60A12	3300022
130	1	Spacer ring 0.656" x 1" x 1.725"	668093
140	1	Spacer ring 0.656" x 1" x 0.772"	667777
150	3	Bearing 1 1/4" – 4 holes	4300118
160	1	Spacer plate	669722
170	1	Drive support	671720
180	1	Flat washer for fan	661554
190	1	Key 3/8" x 3/8" x 2 3/4" lg	654174
200	1	Bolt hex 3/8"NC x 1 1/2" Gr.5 PTD	0100040
210	1	Lockwasher 3/8" PTD	1200004
220	12	Bolt hex 1/2"NC x 1 1/2" Gr.5 PTD	0100070
230	16	Lockwasher 1/2" PTD	1200006
240	16	Nut hex 1/2"NC PTD	0900006
250	13	Plow bolt 3/8" x 1" Gr.5 PTD	0400001
260	13	Stover lock nut 3/8"NC PTD	1100003
270	4	Bolt hex 1/2"NC x 1" Gr.5 PTD.	0100068
280	2	Grease fitting 1/4"NF	654106
290	4	Bolt hex 3/8"NC x 1 1/2" Gr.5 PTD	0100040
300	4	Lockwasher 3/8" PTD	1200003
310	4	Nut hex 3/8"NC PTD	0900003
320	1	Bolt hex 5/8"NC x 4 1/2" Gr.5, PTD	0100104
330	2	Flat washer 5/8" PTD	1400008
340	1	Nut hex 5/8"NC PTD	0900007
350	1	Lockwasher 5/8" PTD	1200007

PARTS

SNOWBLOWER 84" - FRONT

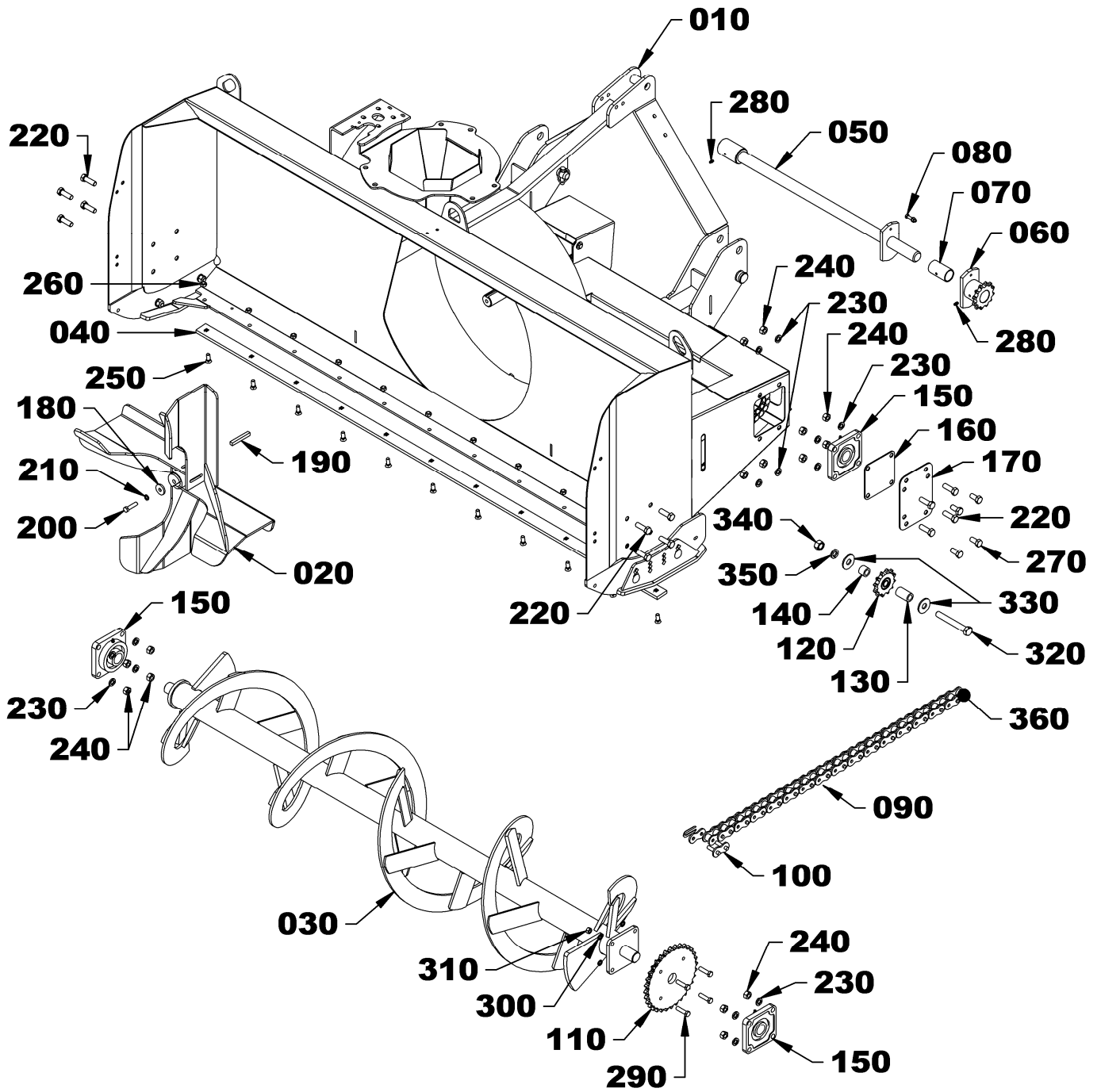

PARTS

SNOWBLOWERS 84" - REAR			
RÉF.	QTY	DESCRIPTION	PART #
010	1	Right skid shoe	671666
020	1	Left skid shoe	671667
030	1	Access panel - shearbolts	671686
040	1	Driveline shield	671682
050	1	Parking stand	668053
060	4	Carriage bolt 1/2"NC x 1 1/4" PTD	0300023
070	4	Lockwasher 1/2" PTD	1200006
080	4	Nut hex 1/2"NC PTD	0900006
090	6	Bolt hex 5/16"NC x 3/4" Gr.5 PTD	0100018
100	6	Nylon insert locknut 5/16"NC PTD	1000005
110	8	Nylon flat washer 1 1/32"	658467
120	1	Bolt hex 1/4"NC x 1 1/4" Gr.5 PTD	0100005
130	1	Nylon insert locknut 1/4"NC PTD	1000003
140	1	Round wire lock pin 1/4" x 1 3/4"	1900006
150	1	Gearbox CCW	663485
160	4	Bolt hex 3/8"NC x 5" Gr.5 PTD	0100051
170	4	Nut hex 3/8"NC PTD	0900003
180	4	Lockwasher 3/8" PTD	1200004
190	2	Pin cat.1 0.866" x 4 7/16" lg	4600065
200	2	Linchpin 7/16" PTD	1900003
210	1	Manual holder	4200030
220	2	Bushing cat.1 & 2 (7/8" int. x 1 1/8" ext. x 2 1/2" lg)	4600066
230	1	Bushing cat .1 & 2 (3/4" dia int. X 1"dia. ext. X 1 3/4" lg)	4600067

PARTS

SNOWBLOWERS 84" - REAR

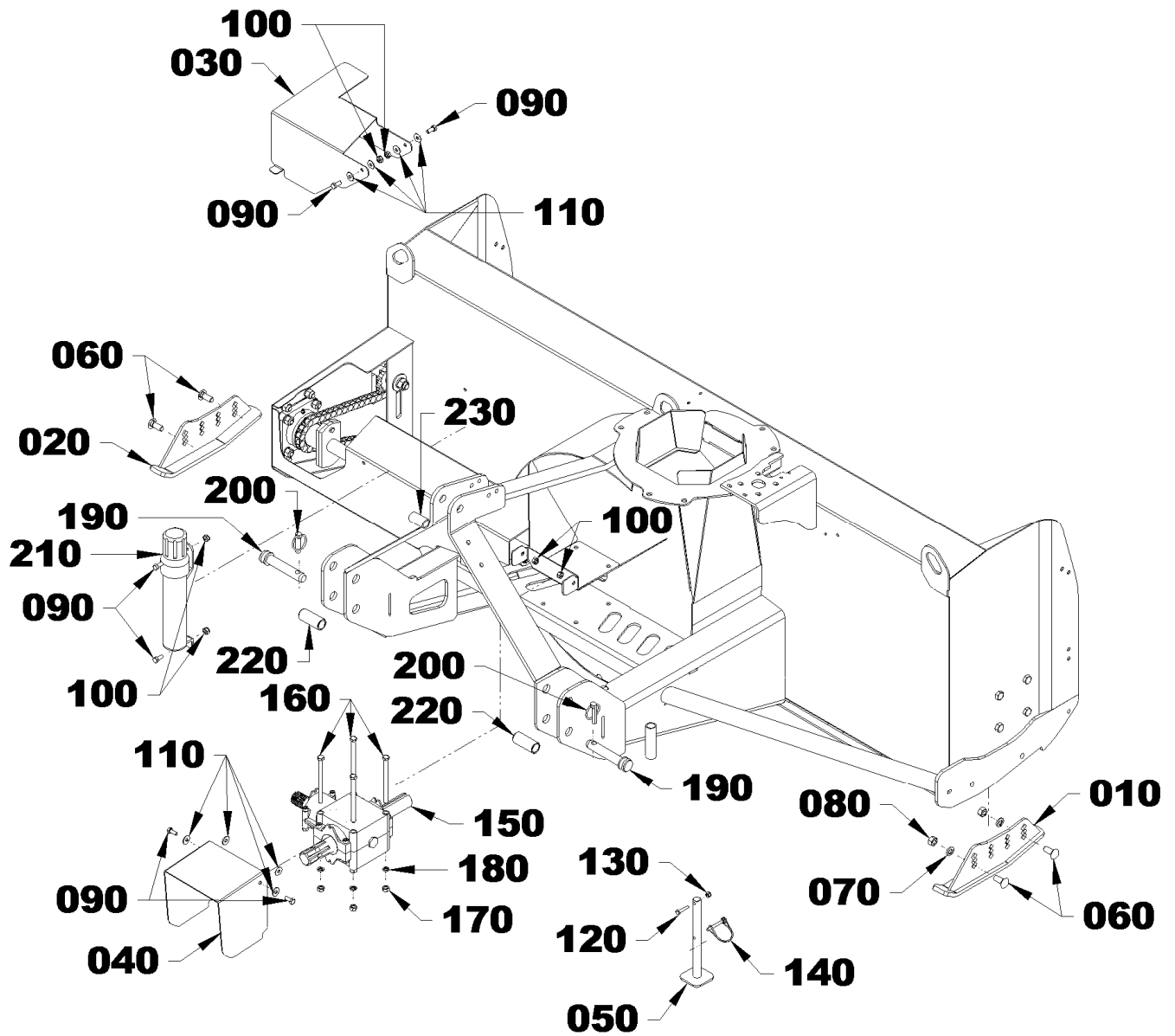

PARTS

CHUTE WITH DEFLECTOR			
REF.	QTY	DESCRIPTION	PART #
010	1	Chute assembly	671865
020	2	Plastic bushing	671671
030	1	Adjustment arm	671685
040	1	Knob 5/16"NC	657309
050	1	Carriage bolt 5/16"NC x 1" PTD	0300003
060	1	Nylon flat washer 11/32"	658467
070	1	Circle cutter PTD	1900011
080	2	Flat washer 1/2" PTD	1400006
090	2	Retaining plate – 3 holes	665935
100	6	Retaining plate spacer 3/8" thick	671734
110	6	Carriage bolt 1/2"NC x 2" PTD	0300026
120	6	Lockwasher 1/2" PTD	1200006
130	6	Nut hex 1/2"NC PTD	0900006
140	1	Rotation bushing	671674
150	3	Retaining plate spacer 11GA, thin, PTD	671824

PARTS

CHUTE WITH DEFLECTOR

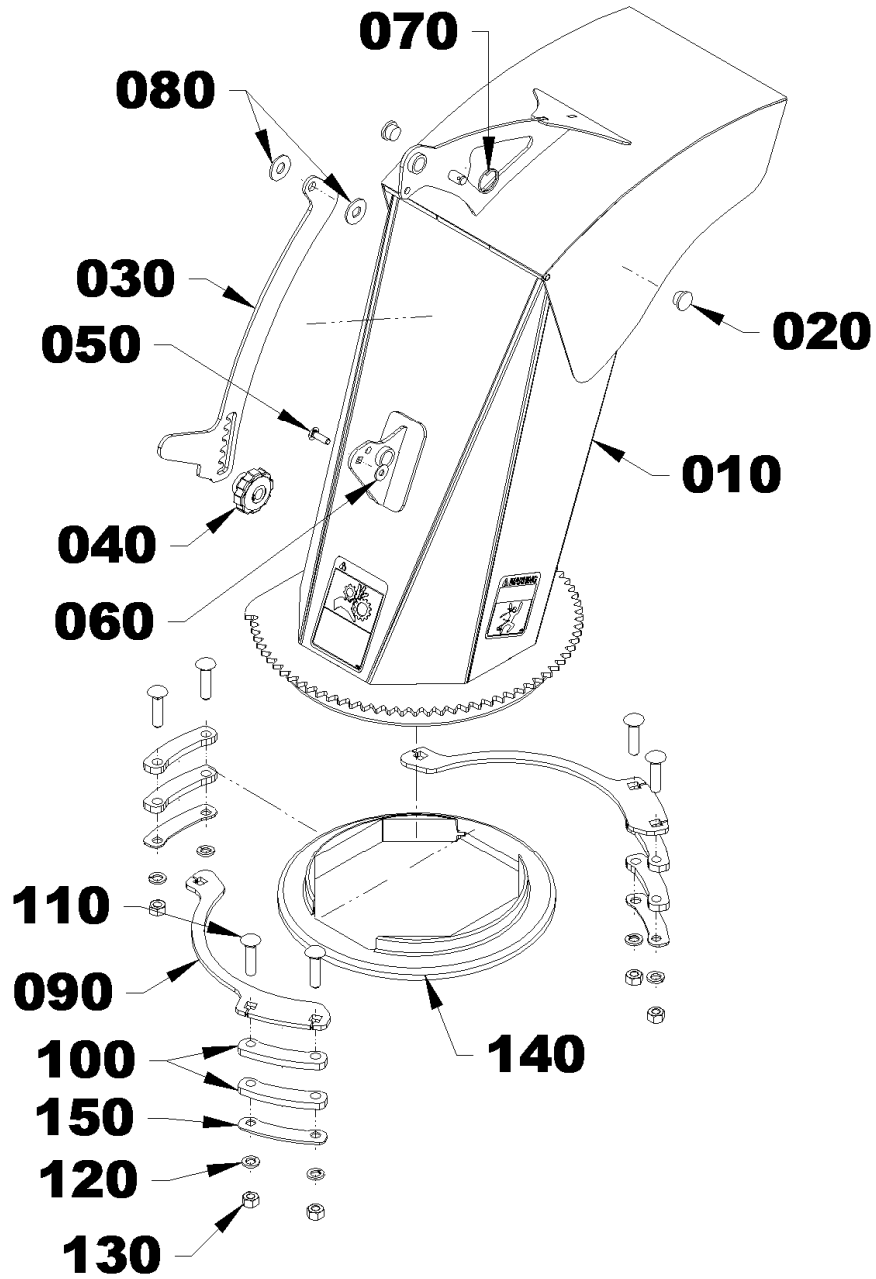

PARTS

GEARBOX - 663485

REF.	QTY	DESCRIPTION	PART #
-	-	Gearbox assembly	663485
010	2	Casing	659848
020	2	Gear	N/A
030	1	Spacer	656649
040	4	Bearing	659844
050	2	Parallel key	659850
060	1	Input shaft	N/A
070	3	Seal kit	659852
080	1	Output shaft	N/A
090	1	Spacer	659854
100	2	Retaining ring	656652
110	2	Spacer	659855
120	1	O-ring	661144
130	1	Plug	659847
140	8	Allen socket head cap screw M8 x 1.25 x 55mm Gr.8.8	0800032
150	8	Nut hex M8 x 1.25	0900022

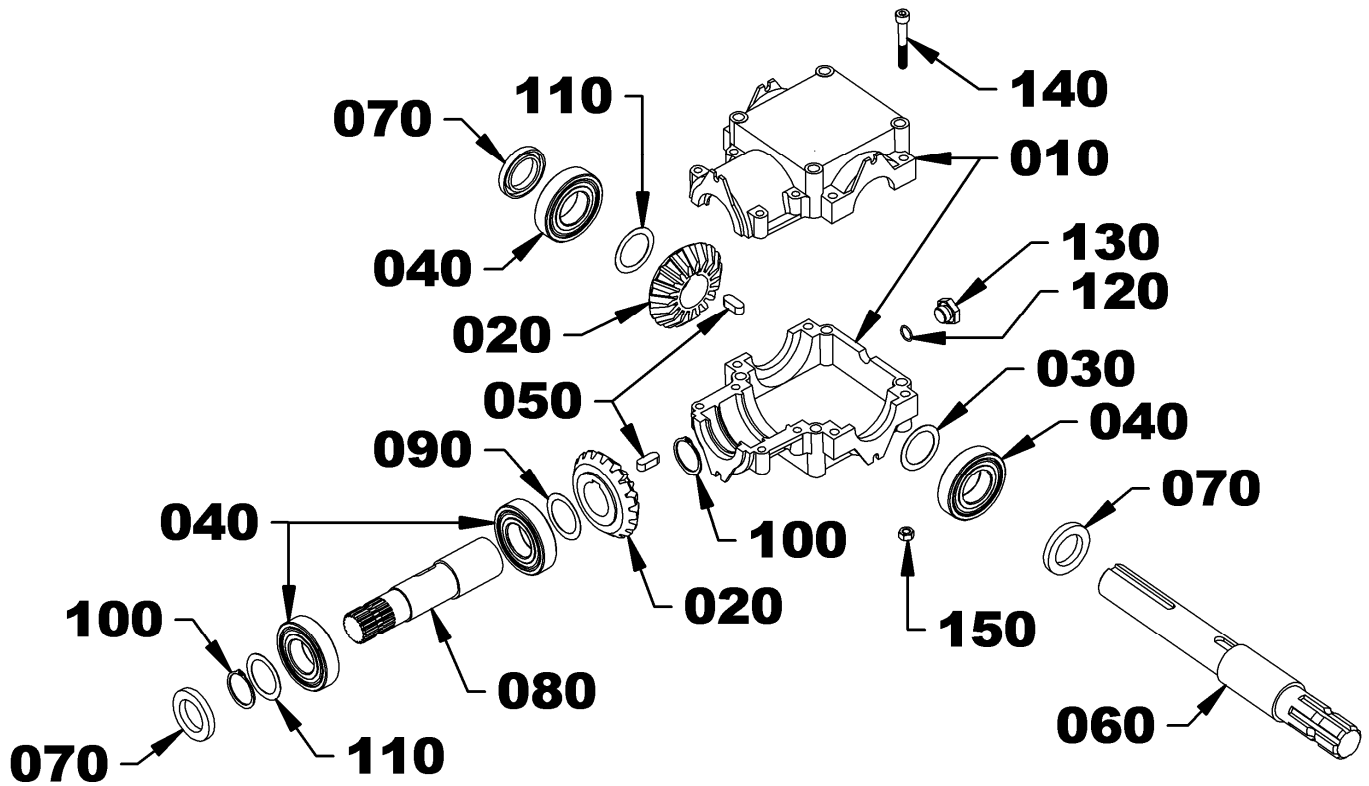

PARTS

DRIVELINE - 662194			
REF.	QTY	DESCRIPTION	PART #
010	1	Yoke assembly	657209
020	2	Universal joint kit	657200
030	1	Yoke and hub assembly	662198
040	2	Bolt M12 x 1.25 x 70mm Gr.8.8 & nut	662199
050	1	Shearbolt M10 x 55mm Gr.8.8 & nut	657199
060	1	Grease fitting	663129
070	1	Shields with safety chain	657221
080	1	Driveline 50 series assembly	662194

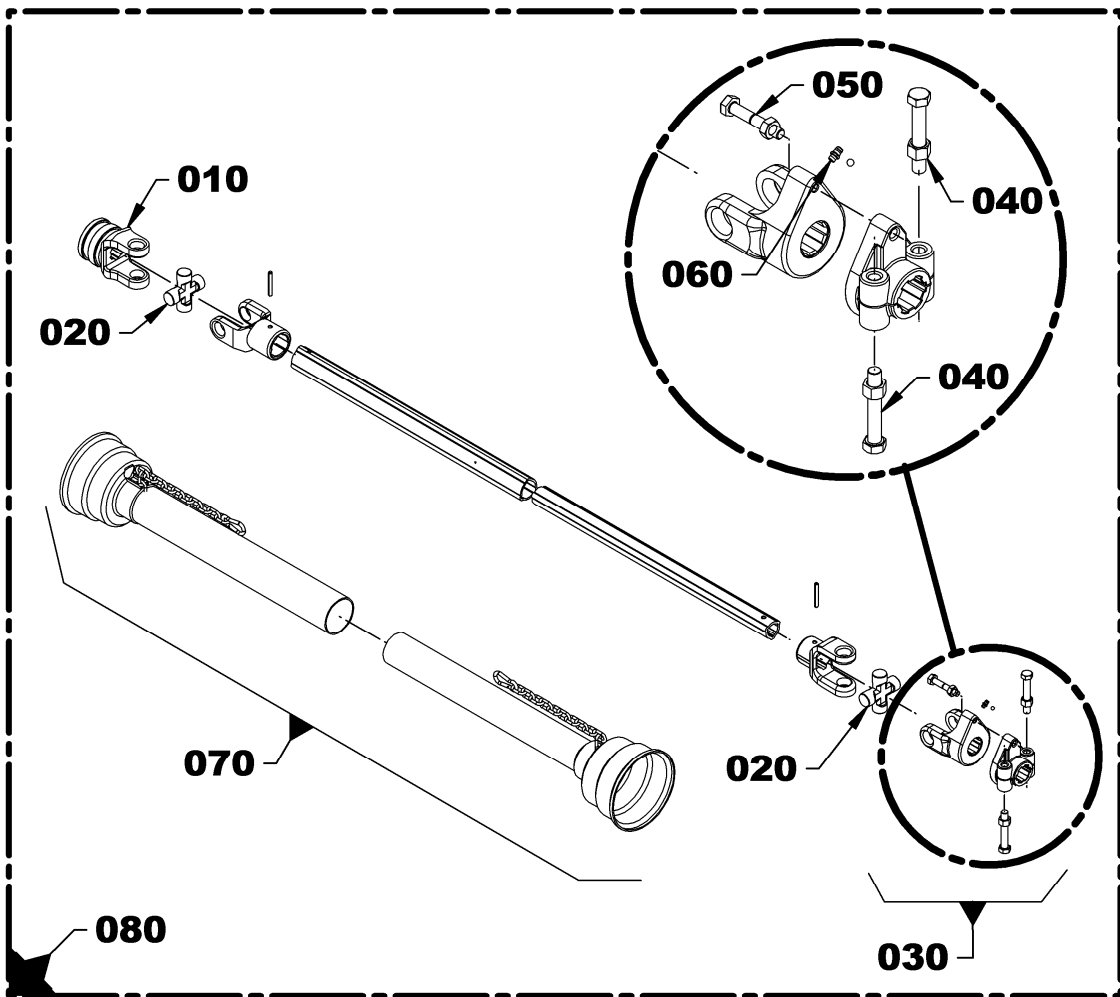

AVAILABLE OPTIONS

MANUAL ROTATION

BER0077

HYDRAULIC ROTATION

BER0078

HYDRAULIC DEFLECTOR

BER0079A

ELECTRIC DEFLECTOR

BER0080







TORQUE SPECIFICATION TABLE

GENERAL SPECIFICATION TABLE

USE THE FOLLOWING TORQUES WHEN SPECIAL TORQUES ARE NOT GIVEN

Note: These values apply to fasteners as received from supplier dry, or when lubricated with normal engine oil. They do not apply if special graphited or moly sulphide greases or other extreme pressure lubricants are used. These values apply to dry conditions; under lubricated conditions reduce by 25% the torques in this table.

BOLT HEAD IDENTIFICATION

INCHES Bolt Size	 Grade 2		 Grade 5		 Grade 8		METRIC Bolt Size	 Class 5.8		 Class 8.8		 Class 10.9	
	in-tpi ¹	N-m ²	lbs-ft ³	N-m	lbs-ft	N-m		lbs-ft	mm x pitch ⁴	N-m	lbs-ft	N-m	lbs-ft
1/4" - 20NC	7.4	5.6	11	8	16	12	M 5 X 0.8	4	3	6	5	9	7
1/4" - 28NF	8.5	6	13	10	18	14	M 6 X 1	7	5	11	8	15	11
5/16" - 18NC	15	11	24	17	33	25	M 8 X 1.25	17	12	26	19	36	27
5/16" - 24NF	17	13	26	19	37	27	M 8 X 1	18	13	28	21	39	29
3/8" - 16NC	27	20	42	31	59	44	M10 X 1.5	33	24	52	39	72	53
3/8" - 24NF	31	22	47	35	67	49	M10 X 0.75	39	29	61	45	85	62
7/16" - 14NC	43	32	67	49	95	70	M12 X 1.75	58	42	91	67	125	93
7/16" - 20NF	49	36	75	55	105	78	M12 X 1.5	60	44	95	70	130	97
1/2" - 13NC	66	49	105	76	145	105	M12 X 1	90	66	105	77	145	105
1/2" - 20NF	75	55	115	85	165	120	M14 X 2	92	68	145	105	200	150
9/16" - 12NC	95	70	150	110	210	155	M14 X 1.5	99	73	155	115	215	160
9/16" - 18NF	105	79	165	120	235	170	M16 X 2	145	105	225	165	315	230
5/8" - 11NC	130	97	205	150	285	210	M16 X 1.5	155	115	240	180	335	245
5/8" - 18NF	150	110	230	170	325	240	M18 X 2.5	195	145	310	230	405	300
3/4" - 10NC	235	170	360	265	510	375	M18 X 1.5	220	165	350	260	485	355
3/4" - 16NF	260	190	405	295	570	420	M20 X 2.5	280	205	440	325	610	450
7/8" - 9NC	225	165	585	430	820	605	M20 X 1.5	310	230	650	480	900	665
7/8" - 14NF	250	185	640	475	905	670	M24 X 3	480	355	760	560	1050	780
1" - 8NC	340	250	875	645	1230	910	M24 X 2	525	390	830	610	1150	845
1" - 12NF	370	275	955	705	1350	995	M30 X 3.5	960	705	1510	1120	2100	1550
1 1/8" - 7NC	480	355	1080	795	1750	1290	M30 X 2	1060	785	1680	1240	2320	1710
1 1/8" - 12NF	540	395	1210	890	1960	1440	M36 X 3.5	1730	1270	2650	1950	3660	2700
1 1/4" - 7NC	680	500	1520	1120	2460	1820	M36 X 2	1880	1380	2960	2190	4100	3220
1 1/4" - 12NF	750	555	1680	1240	2730	2010							
1 3/8" - 6NC	890	655	1990	1470	3230	2380							
1 3/8" - 12NF	1010	745	2270	1670	3680	2710							
1 1/2" - 6NC	1180	870	2640	1950	4290	3160							
1 1/2" - 12NF	1330	980	2970	2190	4820	3560							

- ¹ in-tpi = nominal thread diameter in inches-threads per inch
- ² N-m = newton-meters
- ³ lbs-ft= pounds-foot
- ⁴ mm x pitch = nominal thread diameter in millimeters x thread Pitch

*Torque tolerance +0%, -15% of torquing values. Unless otherwise specified use torque values listed above

ADAPTER INSTALLATION PROCESS

NPT THREAD IDENTIFICATION & TORQUE

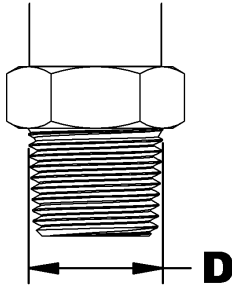

D		Identification of adapter	Number of turns to do after manual tightening
in	mm		
0.375	9.5	1/8 NPT	2.0 - 3.0
0.500	12.5	1/4 NPT	2.0 - 3.0
0.625	15.9	3/8 NPT	2.0 - 3.0
0.780	19.8	1/2 NPT	2.0 - 3.0
0.988	25.1	3/4 NPT	2.0 - 3.0
1.236	31.4	1 NPT	1.5 - 2.5
1.583	40.2	1 1/4 NPT	1.5 - 2.5
1.823	46.3	1 1/2 NPT	1.5 - 2.5

RECOMMENDED ASSEMBLY

The method used to assemble fittings with NPT threads is done in two stages. First firmly tighten by hand then tighten once again according to the number of turns listed in the above table. The following steps are recommended to minimize the risks of leaks and/or damages to the parts.

STEP 1: Inspect threads and tapping to make sure they are clean.

STEP 2: Measure the diameter (D) of the adapter and take note of the size taken.

STEP 3: Apply a sealant/lubricant product to the NPT threads (teflon covered threads are preferable to other lubricating products). If PTFE tape (teflon) is used, make between 1.5 or 2 turns clockwise, when viewed by the fitting end, keeping free the two first threads.

CAUTION: More than 2 turns can cause distortion or cracks in the orifice.

STEP 4: Tighten the fitting manually.

STEP 5: Screw the fitting the number of turns listed on the above table making sure that in the case of an elbow fitting the end is aligned to the desired position to connect the tube or hose. **Never unscrew a fitting to obtain the proper alignment.**

STEP 6: If a leak is detected after having followed the preceding instructions, check that the threads are not damaged and the number of seated threads is fulfilled (see details in next paragraph).

If the threads are damaged, replace the fitting. If the tapping is damaged, retap if possible or replace the part.

Usually, the number of threads seated is between 3.5 and 6. If the range is different it would indicate that the fitting was tightened too much or not enough or that the tightening was not within thread tolerances. If the fitting is not tight enough, tighten but never more than one turn. If it's too tight, control the threading and tapping and replace the section that has threads that are not within tolerances.

ADAPTER INSTALLATION PROCESS

JIC THREAD IDENTIFICATION & TORQUE

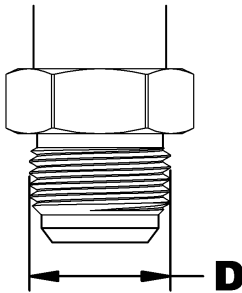

D		Identification of adapter	TORQUE	
in	mm		lbs-ft	N-m
-	-	5/16 JIC	6-7	8-10
-	-	3/8 JIC	6-9	8-12
0.433	11	7/16 JIC	9-12	12-16
0.496	12.6	1/2 JIC	14-15	19-21
0.559	14.2	9/16 JIC	18-20	24-27
0.740	18.8	3/4 JIC	27-39	37-53
0.870	22.1	7/8 JIC	36-63	49-85
1.055	26.8	1 1/16 JIC	65-88	88-119
1.185	30.1	1 3/16 JIC	75-103	102-140
1.307	33.2	1 5/16 JIC	85-113	115-153
1.618	41.1	1 5/8 JIC	115-133	156-180
1.870	47.5	1 7/8 JIC	125-167	169-226
2.492	63.3	2 1/2 JIC	190-258	258-350

JIC flare fittings seal with metal to metal contact between the flared nose of the fitting and the flared tube face in the female connection.

The minimum torque values listed are to provide a benchmark that give optimum results for leak free connections. Actual torque values should be based on individual application.

NOTE: Do not apply thread sealant (teflon tape) on the JIC threads.

Leaks can result from vibration, thermal cycling and from loads being supported by the connection (i.e. using the fitting in the connection to support mechanical loads).

IMPORTANT: Use the lowest torque value from the chart when wet torquing.

RECOMMENDED ASSEMBLY

STEP 1: Inspect for possible contamination or damage from shipping or handling. Sealing surface should be smooth.

STEP 2: Lubricate the threads and the entire surface of the cone with hydraulic fluid or a light lubricant.

STEP 3: Align mating components for hand connection and turn flare nut until sealing surfaces make full contact.

STEP 4: Torque nut to the values shown in the above table.

STEP 5: When torquing nut onto a straight flared fitting, it may be necessary to also place a wrench on the flared fitting wrench pad to prevent it from turning during assembly.

ALTERNATE ASSEMBLY METHOD

STEP 1: Inspect for possible contamination or damage from shipping or handling. Sealing surface should be smooth.

STEP 2: Lubricate the threads and the entire surface of the cone with hydraulic fluid or a light lubricant.

STEP 3: Align mating components for hand connection and turn flare nut until sealing surfaces make full contact.

STEP 4: Lightly wrench tighten the nut until there is resistance.

STEP 5: Place a wrench on wrench pad next to nut as near the 6 o'clock position as possible.

STEP 6: Place second wrench on nut as near the 3 o'clock position as possible.

STEP 7: Turn nut clockwise to no less than the 4 o'clock position, but no more than the 6 o'clock position. Required rotation generally decreases as size increases.

ADAPTER INSTALLATION PROCESS

ORB (O-RING BOSS) THREAD IDENTIFICATION & TORQUE

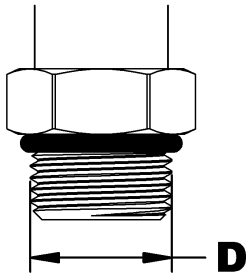

D		Identification of adapter	TORQUE	
in	mm		lbs-ft	N-m
-		3/8 ORB	8-9	12-13
0.433	11	7/16 ORB	13-15	18-20
0.496	12.6	1/2 ORB	14-15	19-21
0.559	14.2	9/16 ORB	23-24	32-33
0.740	18.8	3/4 ORB	40-43	55-57
0.870	22.1	7/8 ORB	43-48	59-64
1.055	26.8	1 1/16 ORB	68-75	93-101
1.185	30.1	1 3/16 ORB	83-90	113-122
1.307	33.2	1 5/16 ORB	112-123	152-166
1.618	41.1	1 5/8 ORB	146-161	198-218
1.870	47.5	1 7/8 ORB	154-170	209-230
2.492	63.3	2 1/2 ORB	218-240	296-325

SAE O-rings (O-Ring Boss) are straight thread fittings that seal using an O-ring between the thread and the wrench flats of the fitting. The O-ring seals against the machined seat on the female port.

O-ring fittings can be either adjustable or non-adjustable. Non adjustable fittings are screwed into a port where no alignment is needed. Adjustable fittings can be oriented in a specific direction.

Fittings with O-rings offer advantages over metal-to-metal fittings. Under or over-tightening any fitting can allow leakage, but all-metal fittings are more susceptible to leakage because they must be tightened to a higher and narrower torque range. This makes it easier to strip threads or crack or distort fitting components, which prevents proper sealing.

NOTE: Do not apply thread sealant (teflon tape) on the ORB threads.

Leaks can also result from vibration, thermal cycling and from loads being supported by the connection (i.e. using the fitting in the connection to support mechanical loads).

IMPORTANT: Use the lowest torque value from the chart when wet torquing.

RECOMMENDED ASSEMBLY ORB (O-RING) NON-ADJUSTABLE

STEP 1: Inspect all components for damage or contamination.

STEP 2: Lubricate O-ring and threads on fitting with your hydraulic system fluid.

STEP 3: Turn fitting into port until finger tight, then torque to the value shown in the following table.

NOTE: Use the lowest torque value from the chart when wet torquing.

RECOMMENDED ASSEMBLY ORB (O-RING) ADJUSTABLE

STEP 1: Inspect all components for damage or contamination.

STEP 2: Lubricate O-ring and threads on fitting with your hydraulic system fluid.

STEP 3: Looking at fitting from the male ORB end, turn manually the nut as far as possible from the O-ring.

STEP 4: Using wrench, turn fitting into port until the washer touches thread nearest wrench pad.

STEP 5: Back off fitting counterclockwise not exceeding one revolution until it is oriented in the correct position.

STEP 6 : Place wrench on the wrench pad of fitting to prevent fitting from turning, and torque nut to the value shown in the above table.

Manufactured by:



Dalkotech Group

RAD Technologies Inc.
2835, Chemin de l'Aéroport
Thetford Mines, Québec, Canada, G6G 5R7

T +1 418 338-4499 - F +1 418 338-2522

info@radtech.ca
radtech.ca

Printed in Canada