

BLIZZARD

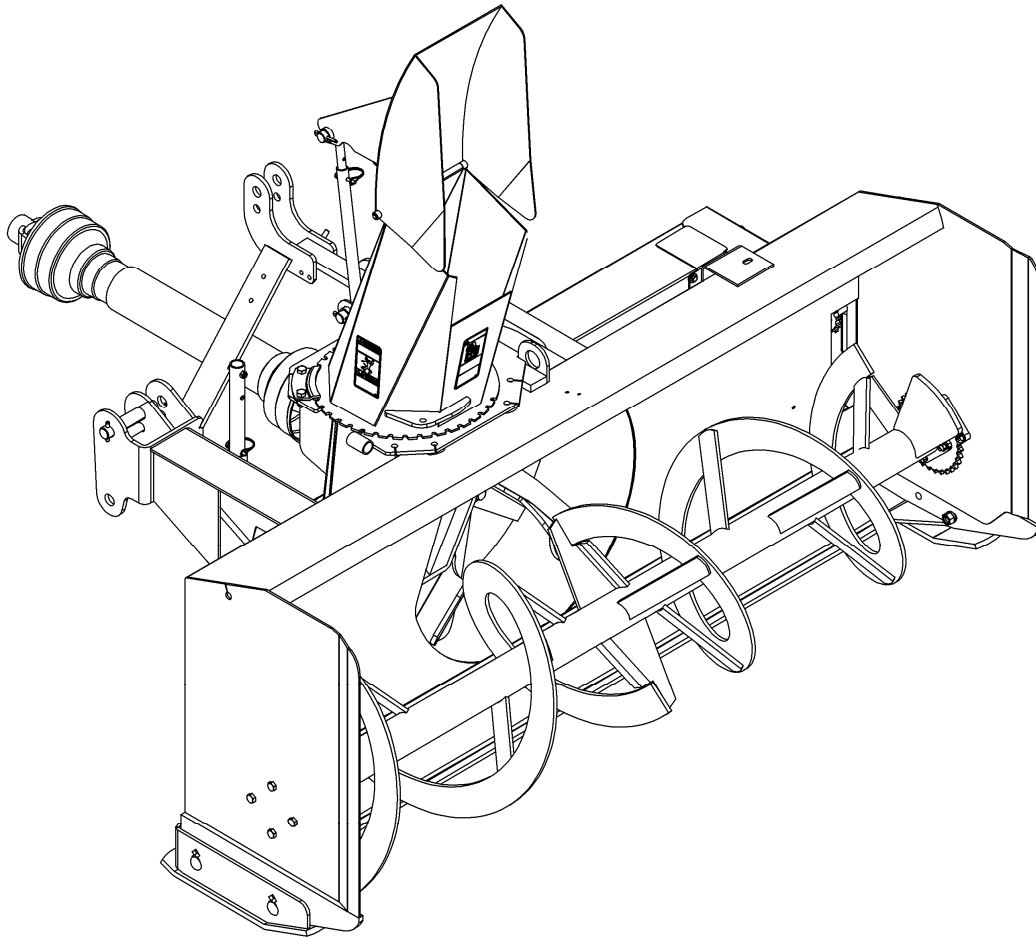

OPERATOR'S AND PARTS MANUAL

**SNOWBLOWER
B84A & B94A MODELS**

SERIAL NO SMT109945 AND UP

**OM 0331-A
10/11**



TABLE OF CONTENT

SPECIFICATIONS.....	3
INTRODUCTION – TO THE PURCHASER.....	4
SAFETY PRECAUTIONS	5-11
Before Operation	5
Notice.....	6
The Snowblower.....	6-8
Before Operation.....	6
Snowblower Operation	7-8
The Tractor	9
General Information	9
Operating the Tractor.....	9
During Operation.....	9
Maintenance	10
Transporting.....	11
Storage	11
SAFETY DECALS	12
ASSEMBLY.....	13-29
Tractor Preparation	13
Snowblower Assembly	13-29
Installation of Chute and Manual Rotation Kit 9377A	13-14
Installation of Chute and Hydraulic Rotation Kit 8046	15-16
Installation of Snowblower with Three Point Hitch	17-18
Installation of Snowblower with Quick Hitch.....	19
Installation of Hydraulic Deflector Kit - 8249 cylinder.....	20
Installation of Electric Deflector Kit 8151	21-23
How to Determine Driveline Angles	24
Angles at Each End of Driveline.....	25
Determining Driveline Length.....	25-26
Driveline Installation.....	27
Removing Snowblower from Tractor	28-29

TABLE OF CONTENT

OPERATION	30-31
General Preparation	30
Operating Controls	30
Work and Travel Speed	30
Raising and Lowering the Snowblower.....	30
Adjustments	30
Reduction Chain Tension Adjustment	30
Skid Shoe Adjustment	30
Manual Deflector Adjustment	30
Snow Removal Methods	31
MAINTENANCE.....	32-36
Maintenance	32
Shearbolts	32
Drive shaft.....	32
Driveline.....	32
Lubrication.....	33
Driveline – Troubleshooting.....	34-36
PARTS	37
Introduction	37
Snowblower – B84.....	38-40
Gearbox 662195	41
Driveline 662194 for B84	42
Driveline 662538 for B94	43
F0016 - Manual Rotation	44
F0018 - Hydraulic Rotation.....	45
F0009 - Hydraulic Deflector.....	46
F0021- Electric Deflector	47
TORQUE SPECIFICATION TABLE	48

SPECIFICATIONS

Features and Specifications	B84	B94
Working Width	84"	94"
Transport Width	84"	94"
Working Height	34"	34"
Length	55 3/8"	55 3/8"
Single/Dual Auger	Single	Single
Auger Diameter	20"	20"
Auger Flighting Thickness	3/8"	3/8"
Impeller Diameter	27 1/2"	27 1/2"
Impeller Width	10 1/2"	10 1/2"
Impeller Shaft Diameter	40 mm (1 9/16")	40 mm (1 9/16")
Number of Impeller blades	4	4
Roller Chain	60H	60H
Drive sprocket (# of teeth)	12	12
Driven sprocket (# of teeth)	32	32
Chain idler	Manual adjustment	Manual adjustment
Gearbox Manufacturer	Comer	Comer
Gearbox Description	Model T-27D	Model T-27D
Tractor RPM	540	540
Impeller RPM	540	540
Auger RPM	200	200
PTO Manufacturer	Comer	Comer
PTO Description	50	60
Skid Shoe	Adjustable	Adjustable
Skid Shoe Material	High carbon steel	High carbon steel
End Plate Thickness	3/16"	3/16"
Back Plate Thickness	11ga	11ga
Impeller Housing Thickness	11ga	11ga
Impeller Blade Thickness	3/8"	3/8"
Side Panel Bottom Thickness	3/16"	3/16"
Cutting Edge	Welded	Welded
Cutting Edge Dimension	1/2" x 3"	1/2" x 3"
Chute Base	Standard	Standard
Parking Stand	Standard	Standard
Hitch Category	Cat. 1 & 2	Cat. 2 only
Quick Hitch Compatibility	ASABE Compatible Cat. 1 & 2	ASABE Compatible Cat. 2 only
HP Requirements - min-max (hp)	35-90	35-90
Operating Weight (lbs)-hyd. rot. & defl.	1130	1182
Shipping Weight (lbs)	1060	1021
Approx. Set-up Time (min.) *	35	35
Chute Deflector Adjustment (standard)	Manual	Manual
Chute Deflector Adjustment (option)	Hydraulic - cylinder (2"x8") Electric - 8" actuator - 1000 lbs. including hardware, switch, and electric cable.	Hydraulic - cylinder (2"x8") Electric - 8" actuator - 1000 lbs. including hardware, switch, and electric cable.
Chute Rotation	Manual - worm gear w/ handle. Hydraulic - cylinder (2"x8")	Manual - worm gear w/ handle. Hydraulic - cylinder (2"x8")
Chute	Two-part	Two-part

* With manual rotation

INTRODUCTION

To THE PURCHASER

All products are designed to give safe, dependable service if they are operated and maintained according to instructions. **Read and understand this manual before operation.**

This manual has been prepared to assist the owner and operators in the safe operation and suitable maintenance of the implements. The information was applicable to products at the time of manufacture and does not include modifications made afterwards.

Read and understand this operator's manual before attempting to put an implement into service. Familiarize yourself with the operating instructions and all the safety recommendations contained in this manual and those labeled on the implements and on the tractor. Follow the safety recommendations and make sure that those with whom you work follow them.

Illustrations

The illustrations may not necessarily reproduce the full detail and the exact shape of the parts or depict the actual models, but are intended for reference only

Direction Reference

Right Hand and Left Hand are determined by those seen by the conductor standing behind the equipment.

The Dealer is responsible for warranty registration of the unit you have purchased. To assist your dealer in handling your needs, please record hereafter the model number and serial number of your implement and tractor. It is also advisable to supply them to your insurance company. It will be helpful in the event that an implement or tractor is lost or stolen.

MODEL :

SERIAL NUMBER :

DATE OF PURCHASE :

SAFETY PRECAUTIONS



SAFETY FIRST

This symbol, the industry's "Safety Alert Symbol", is used throughout this manual and on labels on the machine itself to warn of the possibility of personal injury. Read these instructions carefully. It is essential that you read the instructions and safety regulations before you attempt to assemble or use this unit.

- ⚠ DANGER:** Indicates an immediately hazardous situation which, if not avoided, will result in death or serious injury.
- ⚠ WARNING:** Indicates a potentially hazardous situation which, if not avoided, could result in death or serious injury.
- ⚠ CAUTION:** Indicates a potentially hazardous situation which, if not avoided, may result in minor or moderate injury.
- IMPORTANT:** Indicates that equipment or property damage could result if instructions are not followed.
- NOTE:** Gives helpful information.

All products are designed to give safe, dependable service if they are operated and maintained according to instructions. **Read and understand this manual before operation.** It is the owner's responsibility to be certain anyone operating this product reads this manual, and all other applicable manuals, to become familiar with this equipment and all safety precautions. Failure to do so could result in serious personal injury or equipment damage. If you have any questions, consult your dealer.

BEFORE OPERATION

Children and Bystanders

Tragic accidents can occur if the operator is not alert to the presence of children. Children are generally attracted to machines and the work being done. Never assume children will remain where you last saw them.

1. Keep children out of the operating area and under the watchful eye of another responsible adult.
2. Be alert and turn machine off if children enter the work area.
3. Before and when backing, look behind and look for small children.
4. Never carry children while operating the machine. They may fall off and be seriously injured or interfere with safe operation of the machine.
5. Never allow children to play on the machine or attachment even when turned off.
6. Never allow children to operate the machine even under adult supervision.
7. Use extra care when approaching blind corners, shrubs, trees, or other obstructions that might hide children from sight.

SAFETY PRECAUTIONS - continued

NOTICE

A safe operator is the best insurance against accidents. All operators, no matter how experienced they may be, should read this Operator's Manual and all other related manuals before attempting to operate an implement. Please read the following section and pay particular attention to all safety recommendations contained in this manual and those labeled on the implements and on the tractor.

THE SNOWBLOWER

Before Operation

1. Read and understand this operator's manual and tractor operator's manual. Know how to operate all controls and how to stop the unit and disengage the controls quickly.
2. Never wear loose, torn, or bulky clothing around the tractor and implement. It may catch on moving parts or controls, leading to the risk of accident.
3. Before the snow season, thoroughly inspect the area where the equipment is to be used and remove all doormats, sleds, boards and other foreign objects.
4. Disengage clutch and shift into neutral before starting the engine.
5. Do not operate equipment in wintertime without wearing adequate winter garments.
6. Never attempt to make any adjustments while engine is running. Read this manual carefully to acquaint yourself with the equipment as well as the tractor operator's manual. Working with unfamiliar equipment can lead to accidents. Be thoroughly familiar with the controls and proper use of the equipment. Know how to stop the unit and disengage the controls quickly.
7. Keep all shields in place and properly tighten all mounting hardware.
8. Periodically, inspect all moving parts for wear and replace with authorized service parts if an excessive amount of wear is present.
9. Replace all missing, illegible, or damaged safety and warning decals. See list of decals in the operator's manual.
10. Do not modify or alter this equipment or any of its components, or any equipment function without first consulting your dealer.
11. Keep safety decals clean of dirt and grime.
12. Make sure the tractor is counterweighted as recommended by your dealer. Weights provide the necessary balance to improve stability, traction and steering.

SAFETY PRECAUTIONS - continued

Snowblower Operation

1. Before leaving the tractor/snowblower unattended, take all possible precautions. Park the tractor/snowblower on level ground, place the transmission in neutral, set the parking brake, disengage the PTO, lower the snowblower to the ground, place all levers including auxiliary control levers in neutral, shut off the engine and remove the ignition key.
2. Before starting the tractor/ snowblower, remove the ice that might have accumulated on the auger/fan, inspect and clean every rotating part.
3. Prior to operation, clear work area of all objects that can be picked up and thrown. Mark all curbs, pipes, etc. that cannot be moved.
4. Be sure the PTO switch/lever is in OFF/disengaged position before starting engine.
5. Exercise extreme caution when operating on or crossing a gravel drive, walks, or roads. Stay alert for hidden hazards or traffic.
6. Do not carry passengers.
7. Keep clear of all rotating parts. Do not put hands or feet under, or into snowblower with engine running. Be especially observant of the snowblower areas of discharge, intake or all other mechanical motions.
8. For your safety, do not work under any hydraulically supported machine elements that may creep down, suddenly drop or be accidentally lowered.
9. Park the tractor/snowblower on level ground, place the transmission in neutral, set the parking brake, disengage the PTO, lower the snowblower to the ground, place all control levers in neutral, shut off the engine, remove the ignition key and allow the rotating parts to stop BEFORE unclogging the housing or the chute and making any repairs, adjustments or inspections. Use only a 36" long stick of wood to unclog the snowblower.
10. If the snowblower starts to vibrate abnormally, disengage the PTO, stop the engine immediately and check for cause. Excessive vibration is generally a sign of trouble.
11. Do not run the engine indoors except when starting engine and transporting attachment in or out of building. Carbon monoxide gas is colorless, odorless and deadly.
12. Do not attempt to operate on steep slopes. If operating on slopes is necessary, exercise extreme caution when changing direction.
13. Never operate snowblower without guards, and other safety protective devices in place. All tractor and snowblower shields and covers must be correctly installed at all times. When necessary to remove these, they must be reinstalled immediately.
14. Never operate snowblower near glass enclosures, automobiles, window wells, embankments, etc., without proper adjustment of snow discharge angle.
15. Never operate machine at high transport speeds on a slippery surface.
16. Use extra caution when backing up.
17. Disengage power to auger/fan when transporting or when not in use.
18. Never operate the snowblower without good visibility and lighting.
19. Prolonged exposure to loud noise can cause impairment or loss of hearing. Wear a suitable hearing protective device such as earmuffs or earplugs to protect against objectionable or uncomfortable noises.
20. Never allow anyone near the work area.
21. Never allow anyone to operate the snowblower until they have read the manual completely and are thoroughly familiar with basic tractor and snowblower operation.

SAFETY PRECAUTIONS- continued

- 22.** Make sure the tractor is counterweighted as recommended by your dealer. Weights provide the necessary balance to improve stability, traction and steering.
- 23.** Always make sure all snowblower components are properly installed and securely fastened BEFORE operation.
- 24.** Adjust housing height to clear gravel or crushed rocks surface.
- 25.** Keep away from chute discharge. This chute has the capacity to throw debris at far distances.
- 26.** Never direct chute discharge towards people or animals. A thrown debris can cause serious injury.

SAFETY PRECAUTIONS - continued

THE TRACTOR

General Information

1. Read the operator's manual carefully before using tractor. Lack of operating knowledge can lead to accidents.
2. Do not allow anyone but the operator to ride on the tractor. There is no safe place for extra riders

Operating the Tractor

1. Never run the tractor engine in a closed building without adequate ventilation, as the exhaust fumes are very dangerous.
2. Never allow an open flame near the fuel tank or battery.
3. Make sure the shield is installed when using a PTO-driven equipment and always replace the shield if damaged.
4. Always bring the tractor to a complete stop, shut off the engine, lower the implement to the ground and remove the ignition key before leaving the tractor.
5. Never park the tractor on a steep slope.
6. Do not attempt to operate on steep slopes.
7. Use of tire chains for better traction and stability is recommended.
8. Always drive the tractor at speeds compatible with safety, especially when operating over rough ground, crossing ditches, or when turning.
9. Handle fuel with care, as it is highly flammable.
10. Use approved fuel container.
11. Never add fuel to a running engine or a hot engine.
12. Fill fuel tank outdoors with extreme care. Never fill fuel tank indoors. Replace fuel cap securely and wipe up spilled fuel.
13. Never allow anyone to operate the snowblower until they are thoroughly familiar with basic tractor and snowblower operation.

14. A minimum 20% of tractor and equipment weight must be on the tractor front wheels when attachments are in transport position. Without this weight, tractor could tip over, causing personal injury or death. The weight may be attained with a loader, front wheel weights, ballast in tires or front tractor weights. Weigh the tractor and equipment. Do not estimate.

15. Always make sure all snowblower components are properly installed and securely fastened BEFORE operation.

During Operation

1. Do not allow anyone to ride on the tractor/snowblower at any time. There is no safe place for passengers on this equipment. The operator MUST sit in the tractor seat.
2. Eye and hearing protection is recommended when operating the snowblower.
3. Operate only during daylight hours, or when the area is well lit with bright artificial light.
4. Disengage the PTO (turn to "OFF"), place the transmission in neutral, set the parking brake, shut off the engine and remove the key, and make sure rotating components have stopped BEFORE leaving the operator's seat.
5. Inspect the snowblower after striking any foreign object to assure that all snowblower parts are safe and secure and not damaged.

SAFETY PRECAUTIONS - continued

MAINTENANCE

ALWAYS USE GENUINE PARTS WHEN REPLACEMENT PARTS ARE REQUIRED

1. Keep the tractor and snowblower properly maintained.
2. Park the tractor/snowblower on level ground, place the transmission in neutral, set the parking brake, disengage the PTO, lower the snowblower to the ground, place all control levers in neutral, shut off the engine and remove the ignition key and allow the rotating parts to stop **BEFORE** making any snowblower adjustments.
3. To avoid injury, do not adjust, unblock the driving system, or service the snowblower with the tractor engine running. Make sure rotating components have completely stopped **BEFORE** leaving the operator's seat.
4. Keep the tractor/snowblower clean. Snow, dirt or ice build-up can lead to malfunction or personal injury from thawing and refreezing in garage.
5. Always wear eye protection when cleaning or servicing the snowblower.
6. **DO NOT** service the tractor while the engine is running or hot, or if the unit is in motion. Always lower snowblower to the ground. If necessary to service snowblower in raised position, securely support with stands or suitable blocking before working underneath. Do not rely on hydraulically supported devices for your safety. They can settle suddenly, leak down, or be accidentally lowered.
7. Do not attempt to service machine, clear obstructions or unclog the snowblower with the engine running. Always shut off engine and allow all motion to cease.
8. The manufacturer will not claim responsibility for fitment of unapproved parts and/or accessories and any damages as a result of their use.
9. Make sure all shields and guards are securely in place following all service, cleaning, or repair work.
10. Do not modify or alter this snowblower or any of its components or operating functions. If you have questions concerning modifications, consult with your dealer.
11. Do not operate a snowblower that is defective or has missing parts. Make sure that all recommended maintenance procedures are completed before operating the snowblower.
12. Check all controls regularly and adjust where necessary. Make sure that the brakes are evenly adjusted.
13. Periodically check all nuts and bolts for tightness, especially wheel hub and rim nuts.
14. To avoid serious personal injury: Escaping hydraulic/diesel fluid under pressure can penetrate the skin causing serious injury. Do not use your hands to check for leaks. Use a piece of cardboard or paper to search for leaks. If you are injured by escaping high pressure fluid, see a medical doctor at once.
15. Stop engine and relieve pressure before connecting or disconnecting hydraulic hoses. Tighten all connections before starting engine or pressurizing hoses.

SAFETY PRECAUTIONS - continued

TRANSPORTATION

1. If the tractor/snowblower is to be driven on public roads, it must be equipped with an SMV (Slow Moving Vehicle) sign. Check local traffic codes that may apply to unit usage on public roads and highways in your area.
2. Be alert for all other traffic when driving the tractor/snowblower on public roads or highways.

STORAGE

1. Before storing the snowblower, certain precautions should be taken to protect it from deterioration.
2. Clean the snowblower thoroughly.
3. Make all the necessary repairs.
4. Replace all Safety Signs that are damaged, lost, or otherwise become illegible. If a part to be replaced has a sign on it, obtain a new safety sign from your dealer and install it in the same place as on the removed part.
5. Repaint all parts from which paint has worn or peeled.
6. Lubricate the snowblower as instructed under "Lubrication" section.
7. When the snowblower is dry, oil all moving parts. Apply oil liberally to all surfaces to protect against rust.
8. Attach driveline shield safety chain around driveline by passing it over the upper hitch
9. Store in a dry place.

SAFETY DECALS

Replace immediately if damaged.

DANGER



Avoid Injury From Rotating Auger:

- Keep hands, feet and clothing away.
- Shut off engine before servicing.

Pour Éviter Des Blessures Graves:

- Garder les mains, les pieds et les vêtements éloignés des vis sans fin.
- Arrêter le moteur avant de faire l'entretien.

645

2500783

MEMBER



FEMA

FARM EQUIPMENT MANUFACTURERS ASSOCIATION

662699

DANGER



ROTATING DRIVELINE CONTACT CAN CAUSE DEATH. KEEP AWAY!

ARBRE DE TRANSMISSION
TOUJOURS COUVER LES ENVELOPPES PROTÉCTORICES. NE PAS ACTIONNER L'ÉQUIPEMENT SAUF SI LES ENVELOPPES PROTÉCTORICES SONT EN PLACE. ARRÊTER LE MOTEUR AVANT DE FAIRE L'ENTRETIEN.

NE PAS ACTIONNER L'ÉQUIPEMENT SAUF SI LES ENVELOPPES PROTÉCTORICES SONT EN PLACE. ARRÊTER LE MOTEUR AVANT DE FAIRE L'ENTRETIEN.

DO NOT OPERATE WITHOUT ALL DRIVELINE, TRACTOR AND EQUIPMENT SHIELDS IN PLACE. DRIVELINES SECURELY ATTACHED AT BOTH ENDS. DRIVELINE SHIELD MUST TURN FREELY ON DRIVELINE.

NE PAS ACTIONNER L'ÉQUIPEMENT SAUF SI LES ENVELOPPES PROTÉCTORICES SONT EN PLACE. ARRÊTER LE MOTEUR AVANT DE FAIRE L'ENTRETIEN.

16h 8h 16h 8h 16h 8h

2500813

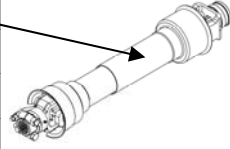

WARNING

Thrown Objects Hazard

- Keep hands, feet and face away from opening.



ATTENTION

Risque De Projection D'objets

- Garder les mains, les pieds et le visage à l'écart de l'ouverture.

647

2500784

DANGER



To Avoid Serious Injury:

- Keep hands out of discharge chute while engine is running.
- Shut off engine before unclogging discharge chute.

Pour Éviter Des Blessures Graves:

- Garder les mains éloignées de la chute lorsque le moteur est en marche.
- Arrêter le moteur avant de débloquer la chute.

648

2500782

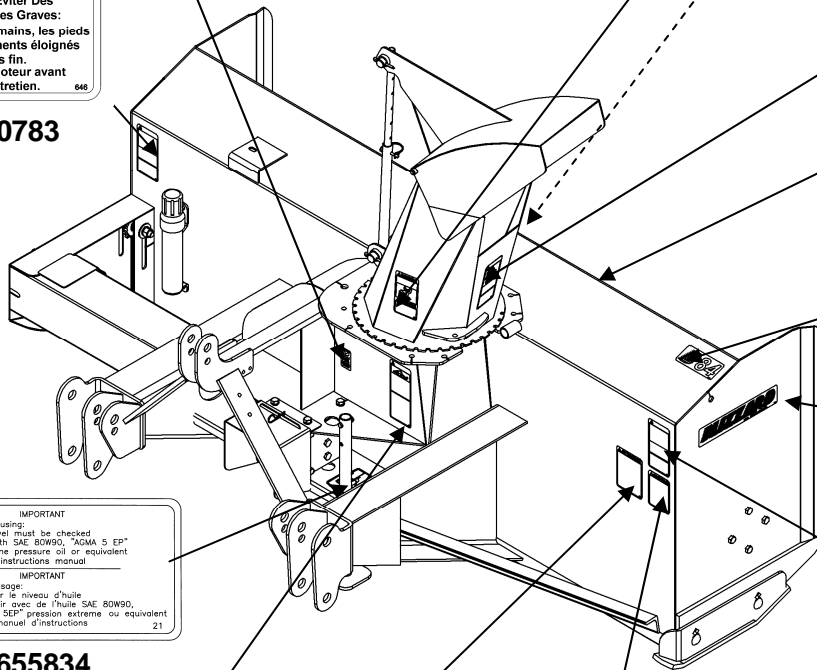

DANGER

664383

B84: 664497
B94: 664498

BLIZZARD

664458

IMPORTANT

Before using:

- Oil level must be checked
- Fill with SAE 80W90, "AGMA 5 EP" extreme pressure oil or equivalent
- Read instructions manual

IMPORTANT

Avant usage:

- Vérifier le niveau d'huile
- Remplir avec de l'huile SAE 80W90, "AGMA 5EP" pression extrême ou équivalent
- Lire manuel d'instructions

21

655834

DANGER



Avoid Injury From Rotating Auger:

- Keep hands, feet and clothing away.
- Shut off engine before servicing.

Pour Éviter Des Blessures Graves:

- Garder les mains, les pieds et les vêtements éloignés des vis sans fin.
- Arrêter le moteur avant de faire l'entretien.

645

2500783

DANGER



Rotating Driveline Contact Can Cause Death. Keep People And Clothing Away. Do not operate without:

- All driveline, tractor and equipment shields in place.
- Driveline securely attached at both ends.
- Driveline shield turning freely on driveline.

Transmission Rotative À Cardan. Tout Contact Peut Causer La Mort. Tenir Les Vêtements Et Personnes À L'écart. Ne pas opérer sans:

- Que tous les protecteurs du tracteur, de l'équipement et de l'arbre à cardan soient en place.
- L'arbre à cardan fixé solidement à chaque bout.
- Que les protecteurs tournent librement sur l'arbre à cardan.

652

2500792

ATTENTION

Pour Éviter Des Blessures Sérieuses:

- Lire le Manuel de l'opérateur avant de manoeuvrer, d'effectuer l'entretien ou de réparer l'équipement. Suivre toutes les consignes de sécurité. Les manuels sont disponibles chez votre concessionnaire.
- Ne jamais laisser des passagers monter sur l'équipement.
- Garder les spectateurs loin de l'équipement pendant les opérations.
- Toujours manoeuvrer l'équipement à partir du siège du tracteur.
- Maintenir les gardes en place en tout temps et en bonne condition.
- Abaisser l'équipement au sol, couper le contact, retirer la clé et appliquer le frein avant de quitter le tracteur.
- Ne jamais laisser un enfant ou une personne non formée manoeuvrer l'équipement.

649

2500786

CAUTION

To Avoid Serious Injury:

- Read operator's manual before operating, servicing or repairing equipment. Follow all safety rules and instructions. (manuals are available from your selling dealer.)
- Never allow riders.
- Keep bystanders away from equipment during operation.
- Operate from tractor seat only.
- Keep all shields in place and in good condition.
- Lower equipment to ground, stop engine, remove key and set brake before dismounting tractor.
- Never allow children or untrained persons to operate equipment.

648

2500785

LOCATED ON HYDRAULIC ROTATION

DANGER



CONTACT DURING USE WILL RESULT IN SERIOUS INJURIES. TOUT CONTACT PENDANT L'UTILISATION CAUSERA DES BLESSURES GRAVES.

239

664548

ASSEMBLY

TRACTOR PREPARATION

See Dealer for Tractor Preparation information.

SNOWBLOWER ASSEMBLY

The snowblower is assembled at the factory however snowblower kits must be assembled. Use the present manual and lay out all parts for assembly. Separate bolts and nuts into various sizes. After assembly, torque all the bolts according to the **Torque Specification Table** at the end of manual.

Installation of Chute and Manual Rotation Kit - 9377A

(Figures 1 to 4)

NOTE: The rotation handle can be installed on the right or left side of the three point hitch.

1. **Figure 1:** Apply grease on the chute base and around the snowblower chute ring and install the chute (item 1).
2. **Figure 2:** Insert the 1 11/16" plastic bushing (item 1) in the worm support bracket (item 2) and insert the longest end of the rotation worm (item 3).
3. **Figure 2:** Insert the 1 5/16" plastic bushing (item 4) in the welded tube of the snowblower (item 5).
4. **Figure 2:** Place the support (item 2) and the support spacer (item 10) under the snowblower's right upper plate (item 6).
5. **Figure 1:** Install the chute with the four retaining plates (item 3), four spacers (item 2), eight 1/2" x 1 1/4" bolts and eight serrated flange nuts (items 4-5). Tighten securely.
6. **Figure 2:** Insert the rotation tube (item 7) in the worm assembly aligning the holes, insert an Allen socket head capscrew 10-24 x 1" (item 8) making sure the screw sinks into the rotation worm and secure with a nylon insert nut (item 9).



CAUTION

To avoid personal injury, check the full lifting range of the snowblower, to ensure that the chute rotation handle is clear of the operator's area when the snowblower is in raised position.

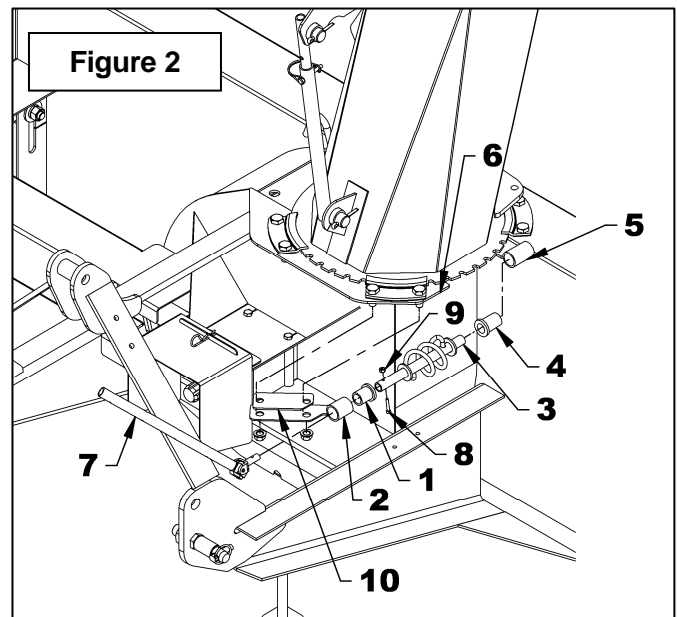
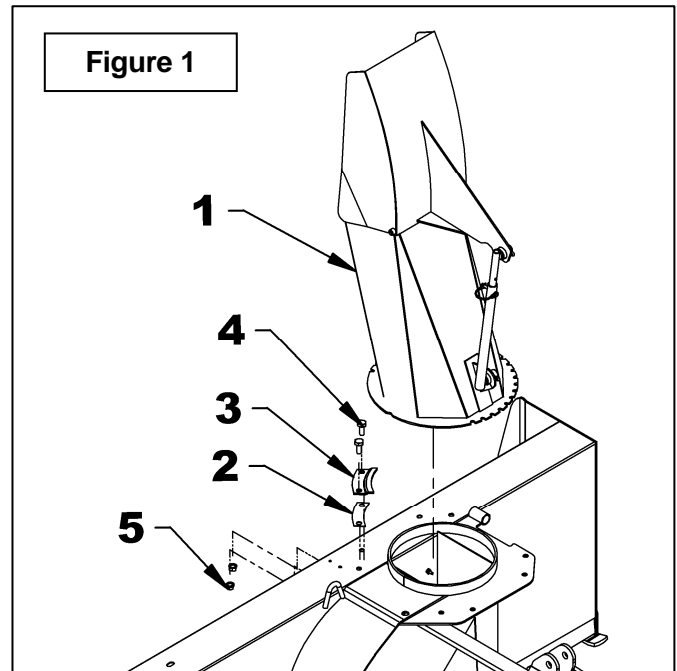

ASSEMBLY

7. **Figure 3:** Install the rotation bracket (item 1) on the left or right arm of the three point hitch with two 3/8" NC x 1 1/4" bolts, lockwashers and nuts (items 2-3-4). Tighten firmly.
8. **Figure 3:** Attach the handle support bracket (item 5) to the rotation bracket (item 1) with a 3/4"NC x 1 1/4" bolt, lockwasher and nut (items 6-7-8) making sure to attach the brackets in the direction illustrated.
9. **Figure 3:** Insert the handle support (item 9) in the bracket (item 5) adjusting the height of the support according to your needs and secure in place with a 3/8" x 1/2" square head setscrew (item 10).
10. **Figure 3:** Insert the grommet (item 11) in the handle support (item 9).
11. **Figure 4:** Insert the handle (item 1) in the handle support (item 4) and in the rotation tube. Select desired length, align nearest holes and secure with the 4 mm x 80mm hairpin (item 2). Install the plastic handle (item 3).
12. **Figure 3:** Once the snowblower is attached to the tractor, adjust handle position and height to ensure comfort and safe operation. Tighten setscrew (item 10) on the handle support as well as the 3/4" x 1 1/2" bolt, 3/4" lockwasher and 3/4" nut (items 6-7-8).
13. **Figure 4:** To insure the manual rotation functions properly, position the handle support (item 4) the closest possible to the top link mounting point of the three point hitch while making sure it does not come into contact with the operator's seat when the snowblower is fully raised.
14. Tighten all bolts according to the **Torque Specification Table** at the end of the manual.

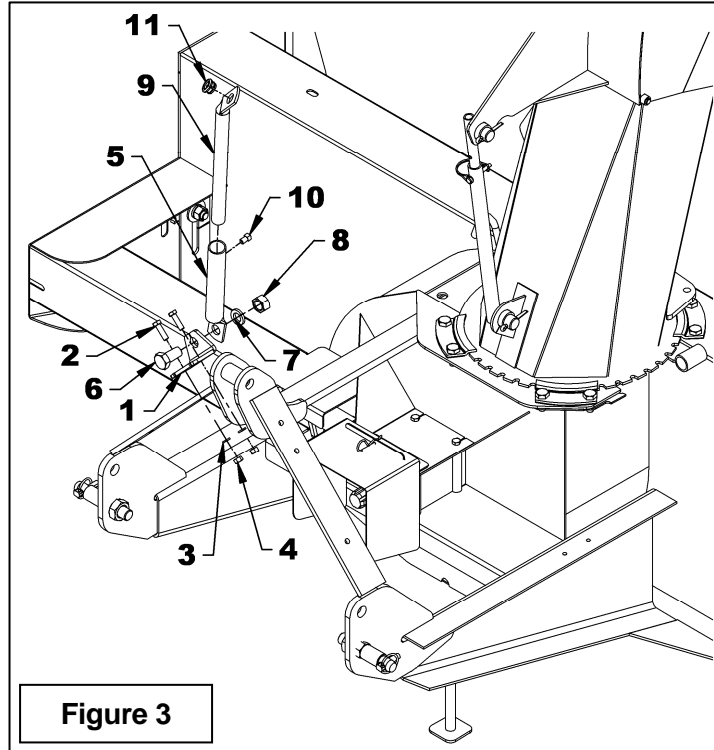

Figure 3

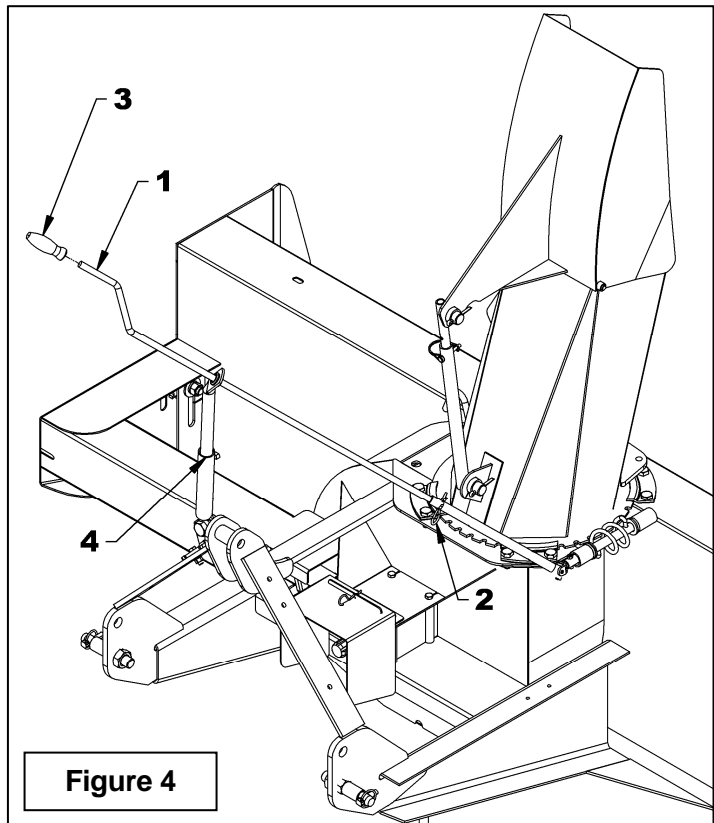

Figure 4

ASSEMBLY

Installation of Chute and Hydraulic Rotation Kit - 8046

(Figures 5-6-7)

- Figure 5:** Place the hole identified "POSITION" over the indentation in the housing.
- Figure 5:** Apply grease on the chute base and around the snowblower chute ring and install the chute with the four retaining plates (item 1), eight 1/4" x 3/4" bolts and eight serrated flange nuts (items 2-3). Do not tighten immediately.
- Figure 5:** Attach the rotation bracket (item 5) in the slot on the left side of the housing with a 1/2"NC x 1 1/4" hex. bolt and a 1/2" serrated flange nut (items 6-7).
- Figure 5:** Place the spacer ring (item 8) on the 13/16" hole of the housing; insert the pivot bushing (item 9) in the bell crank (item 10) and slide the bell crank between the flat bars of the rotation bracket (item 5).
- Figures 5-6:** Attach the other end of the bracket and the bell crank (fig. 7, items 5-10) in the 13/16" hole of the housing with the 3/4"NC x 5" hex. bolt, a 3/4" lockwasher and a 3/4" hex. nut (fig. 8, items 1-2-3) in the exact order shown. Tighten securely.
- Figure 5:** Grease generously both holes of the push arm (item 17) and install one end under the flat bar welded on the base of the chute and secure with a 1/2" x 1" shoulder screw, two 9/16" hole flat washer, a 3/8" hole flat washer and a 3/8"NC stover nut (items 14-18-15-16) in the exact order shown. Tighten leaving some movement to the mechanism.
- Figure 5:** Install the other end of the push arm (item 17) under the bell crank (item 10) and secure with a 1/2" x 1" shoulder screw, a 9/16" hole flat washer, a 3/8" hole flat washer and a 3/8"NC stover nut (items 19-18-20-21) in the exact order shown. Tighten leaving some movement to the mechanism.
- Figure 5:** Attach the fixed section of the cylinder (item 4) to the rotation bracket (item 5) and the sliding section to the bell crank (item 10) placing a $\varnothing 1\ 1/16"$ flat washer (item 22) between the cylinder yoke and the top of the bell crank then secure with the cylinder pins and the snap ring. Point the hydraulic ports upward as illustrated.
NOTE: The 1 1/16" flat washer (item 22) is required only if the cylinder pin rubs against the snowblower housing
- Figure 7:** Connect the 3/8" ends of both hoses (item 2) to the cylinder (item 1) and install a quick coupler with rubber dust cap (items 6-7) at the end of each hose.
- Figure 7:** Secure the hoses on the three point hitch with the hose clamp, 3/8" NC x 1 1/2" lg bolt and 3/8" NC nylon insert nut (items 4-3-5) and attach hoses together with the nylon tie wraps (item 8) where needed.



CAUTION

To avoid serious personal injury. Escaping hydraulic/ diesel fluid under pressure can penetrate the skin causing serious injury.

- Do not use your hands to check for leaks. Use a piece of cardboard or paper to search for leaks.**

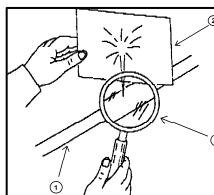
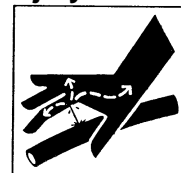

- Hydraulic hose
- Cardboard
- Magnifying glass

- Stop engine and relieve pressure before connecting or disconnecting lines.**
- Tighten all connections before starting engine or pressurizing lines.**

If any fluid is injected into the skin, obtain medical attention immediately or gangrene may result.

ASSEMBLY

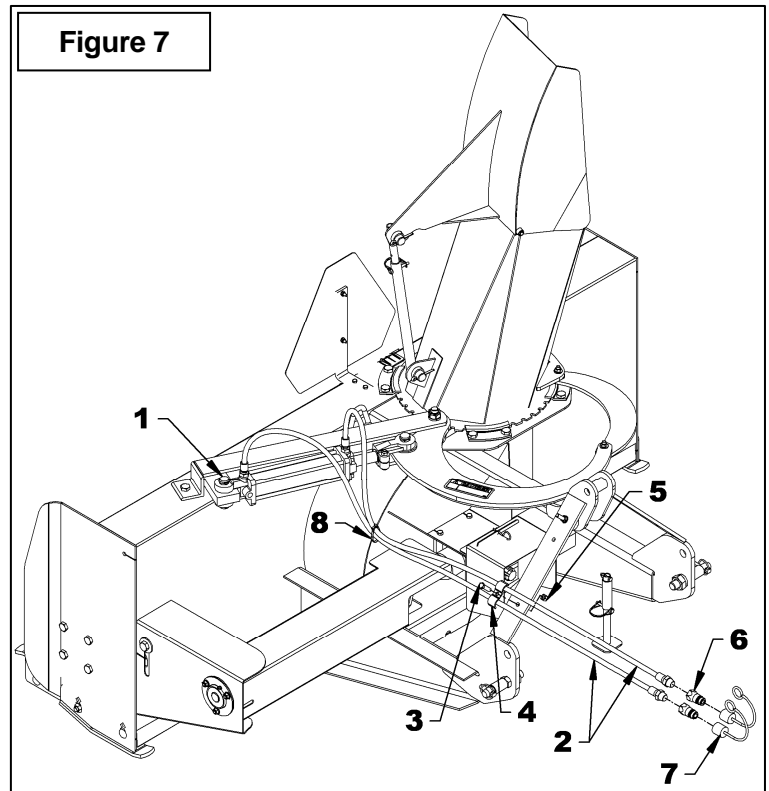
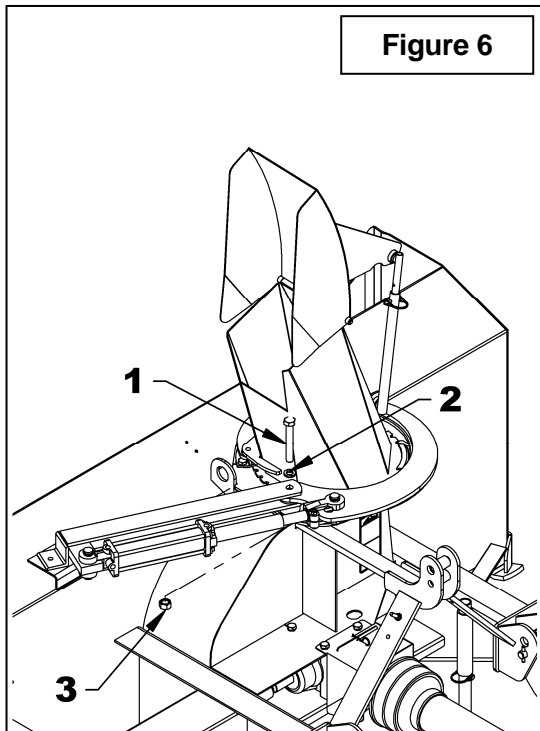
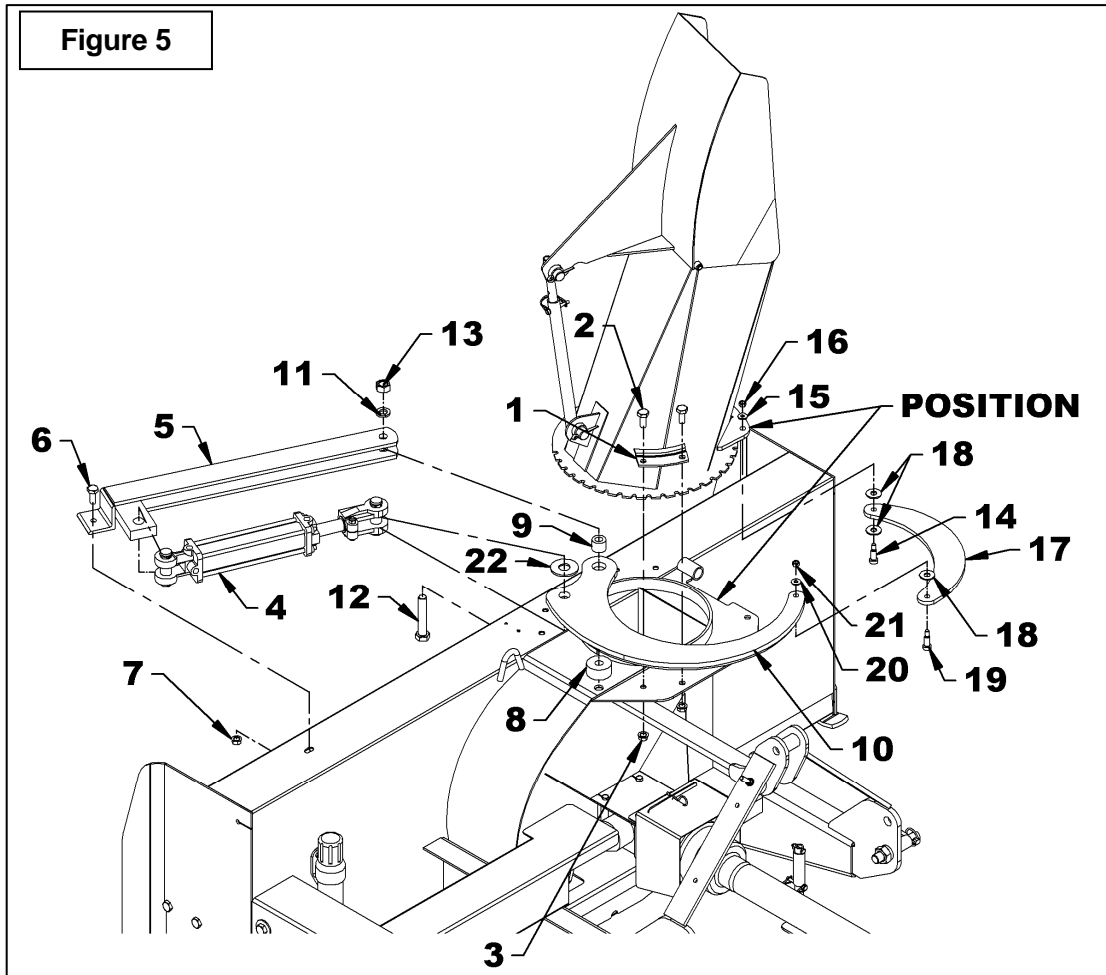

ASSEMBLY

Installation of Snowblower with Three Point Hitch

(Figures 8-9-10)

B84 (Figures 8-9)

CATEGORY 1

(Figure 8)

1. Install the two cat.1 pins (item 1) on the right and left snowblower hitches in the lower holes of the inside plates as shown on figure.
2. Attach tractor lower links (item 2) to the snowblower hitch pins (item 1) and secure with the linchpins (item 3).
3. Attach the tractor upper link (item 4) between the upper attaching plates (item 6) using the pin and linchpin (item 5 – not included).
4. Adjust the snowblower using the tractor upper link so that the snowblower operates parallel to the ground.
5. Set the tractor anti-sway turnbuckles so the snowblower does not sway making sure there is no contact with the tires.
6. Install the eyebolt (item 7) in the upper hole of the left or right side of the three point hitch by screwing the eyebolt nut to the top and locking eyebolt in place with a 3/8" serrated flange nut (item 8).



CAUTION

Before connecting snowblower driveline to tractor drive shaft, make sure driveline is not too long in raised, lowered and middle position. If the driveline is too long it must be shortened, to avoid damaged to tractor. See pages 24 to 26 for instructions.

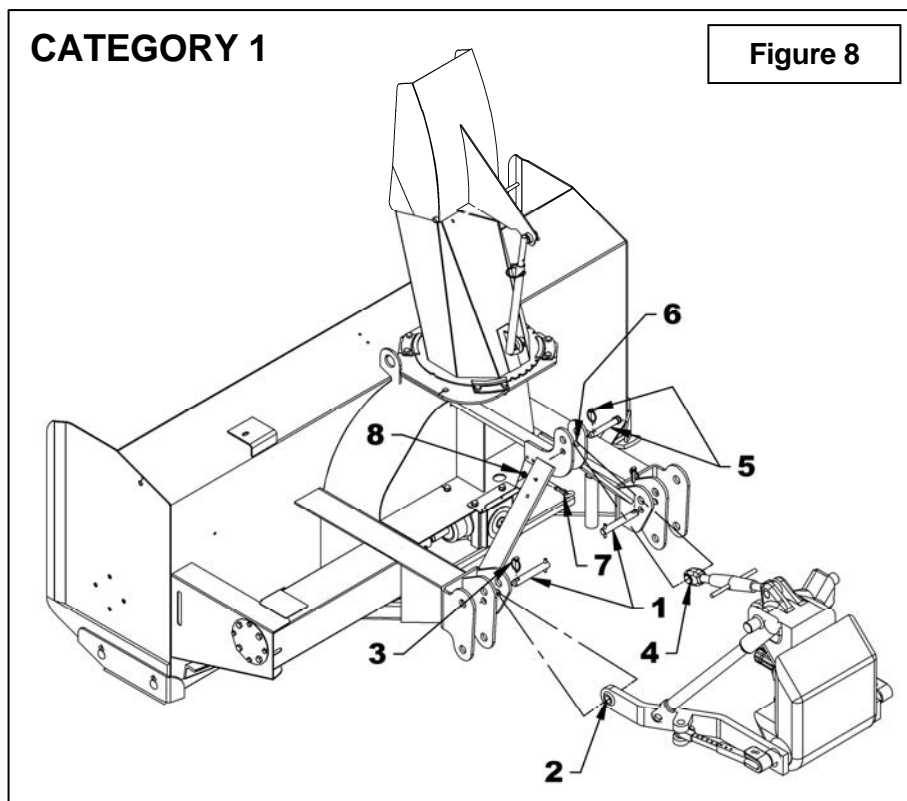

ASSEMBLY

B84 & B94

CATEGORY 2

(Figure 9)

1. Install the two cat. 2 pins (item 1) on the right and left snowblower hitches in the lower holes of the outside plates as shown on figure.
2. Attach tractor lower links (item 2) to the snowblower hitch pins (item 1) and secure with the linchpins (item 3).
3. Attach the tractor upper link (item 4) between the upper attaching plates (item 6) using the tractor pin and linchpin (item 5 – not included).
4. Adjust the snowblower using the tractor upper link so that the snowblower operates parallel to the ground.
5. Set the tractor anti-sway turnbuckles so the snowblower does not sway. Be sure there is no contact with the tires.
6. Install the eyebolt (item 7) in the upper hole of the left or right side of the three point hitch by screwing the eyebolt nut to the top and locking eyebolt in place with a 3/8" serrated flange nut (item 8).



CAUTION

Before connecting snowblower driveline to tractor drive shaft, make sure driveline is not too long in raised, lowered and middle position. If the driveline is too long it must be shortened, to avoid damaged to tractor. See pages 24 to 26 for instructions.

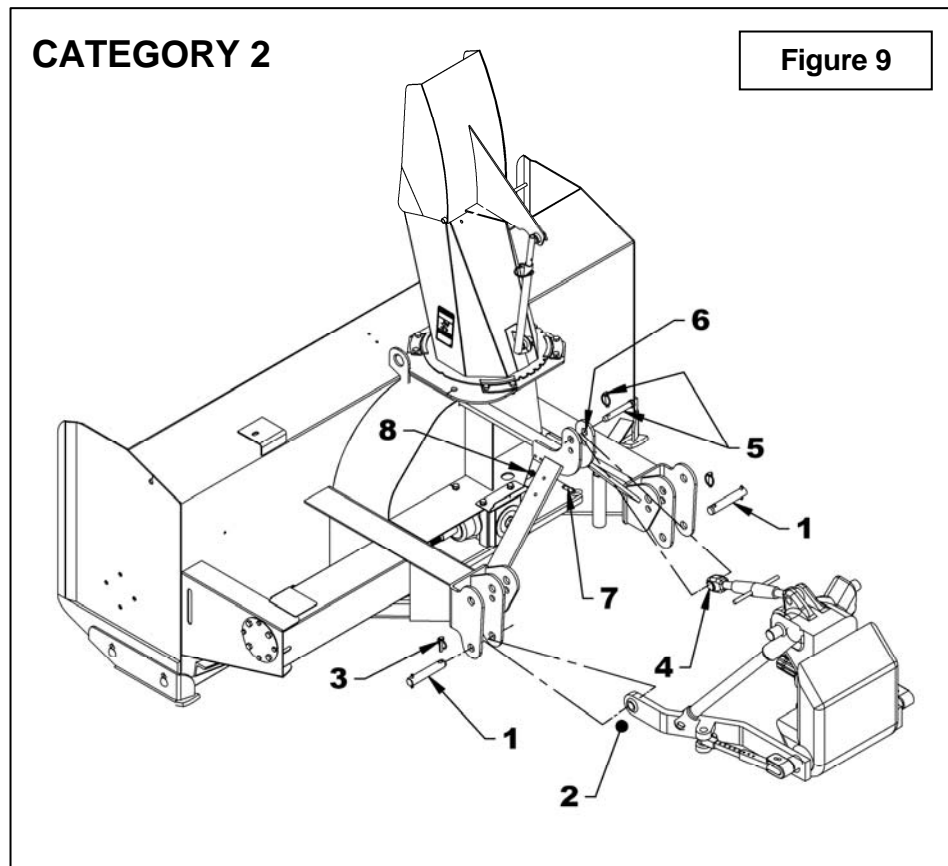

ASSEMBLY

Installation of Snowblower with Quick Hitch (Figures 10-11)

B84

CATEGORY 1 (Figure 10)

1. Place the two 1 1/2" x 2 1/8" lg bushings (item 3) between upper holes of the interior and middle plates, insert the 1 1/8" x 6 1/4" lg cat.2 pins (item 2) **from the inside** and lock in place with 7/16" linchpins (items 4).
2. Insert the 1 7/8" lg bushing (item 5) between the upper attaching plates and lock in place with the 3/4" x 5 7/16" pin and a 7/16" linchpin (items 6-7).
3. Install the eyebolt (item 8) in the upper hole of the left or right side of the three point hitch by screwing the eyebolt nut to the top and locking eyebolt in place with a 3/8" serrated flange nut (item 9).



CAUTION

Before connecting snowblower driveline to tractor drive shaft, make sure driveline is not too long in raised, lowered and middle position. If the driveline is too long it must be shortened, to avoid damaged to tractor. See pages 24 to 26 for instructions.

B84 & B94

CATEGORY 2 (Figure 11)

1. Place the two 1 1/2" x 3 3/8" lg bushings (item 3) between upper holes of the exterior and middle plates, insert the 1 1/8" x 6 1/4" lg cat.2 pins (item 2) **from the outside** and lock in place with 7/16" linchpins (items 4).
2. Insert the 1 7/8" lg bushing (item 5) between the upper attaching plates and lock in place with the 3/4" x 5 7/16" pin and a 7/16" linchpin (items 6-7).
3. Install the eyebolt (item 8) in the upper hole of the left or right side of the three point hitch by screwing the eyebolt nut to the top and locking eyebolt in place with a 3/8" serrated flange nut (item 9).



CAUTION

Before connecting snowblower driveline to tractor drive shaft, make sure driveline is not too long in raised, lowered and middle position. If the driveline is too long it must be shortened, to avoid damaged to tractor. See pages 24 to 26 for instructions.

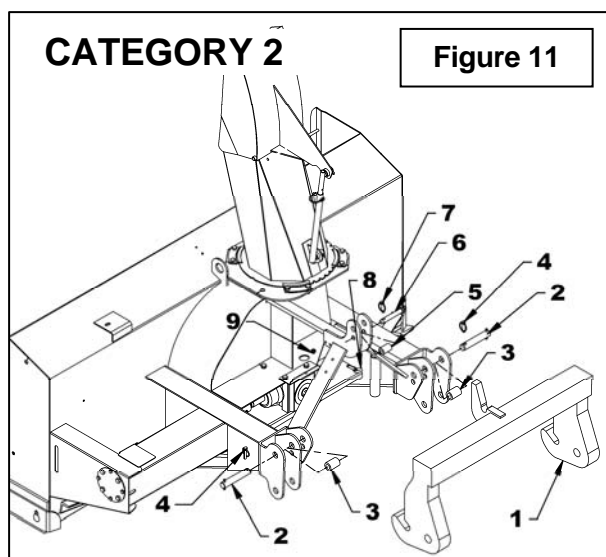
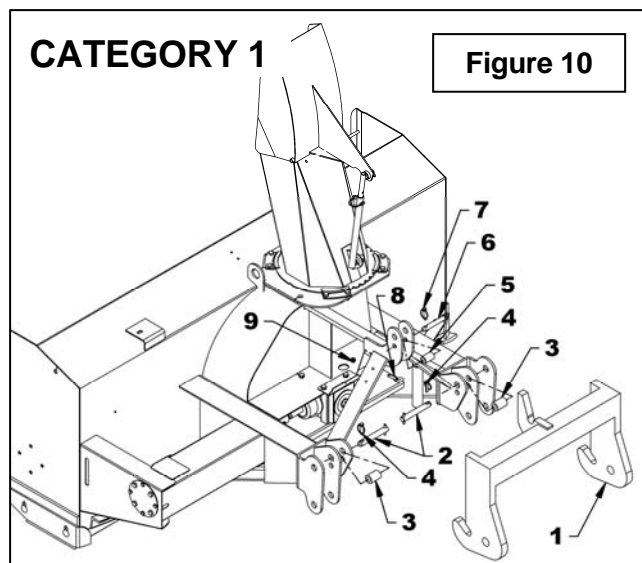

ASSEMBLY

Installation of Hydraulic Deflector Kit - 8249 Cylinder (Figures 12-13)

1. **Figure 12:** Remove a snap ring (items 1-4) from each cylinder pin (items 2-3) and remove the pins. Placing the hydraulic ports in the position shown on figure 14, attach the fixed end of the cylinder (item 6) to the chute base (item 5) and the rod end to the upper chute bracket with the pins and snap rings (items 1-2-3-4).
2. **Figure 13:** Connect the 3/8" ends of both hoses (item 2) to the cylinder (item 1) and install a quick coupler with rubber dust cap (items 6-7) at the end of each hose.
3. **Figure 13:** Secure the hoses on the three point hitch with the hose clamp, 3/8" NC x 1 1/2" lg bolt and 3/8" NC nylon insert nut (items 4-3-5) and attach hoses together with the nylon tie wraps (item 8) where needed.

Note: Make sure to leave enough slack for the hoses to allow complete rotation movements.

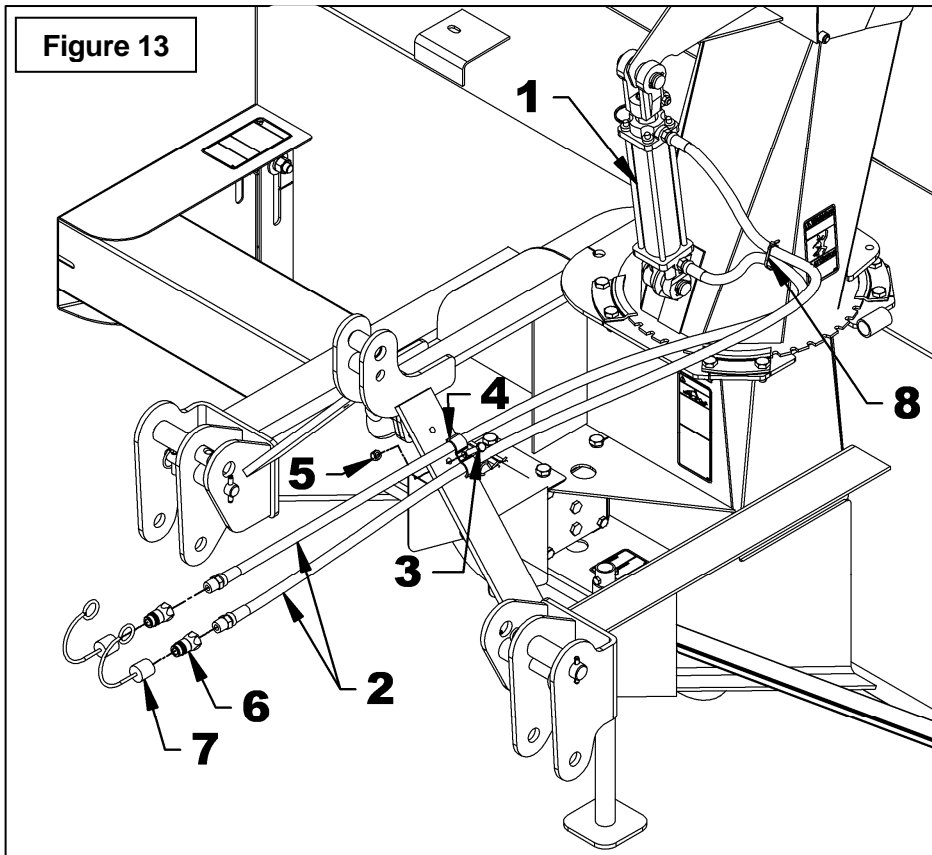
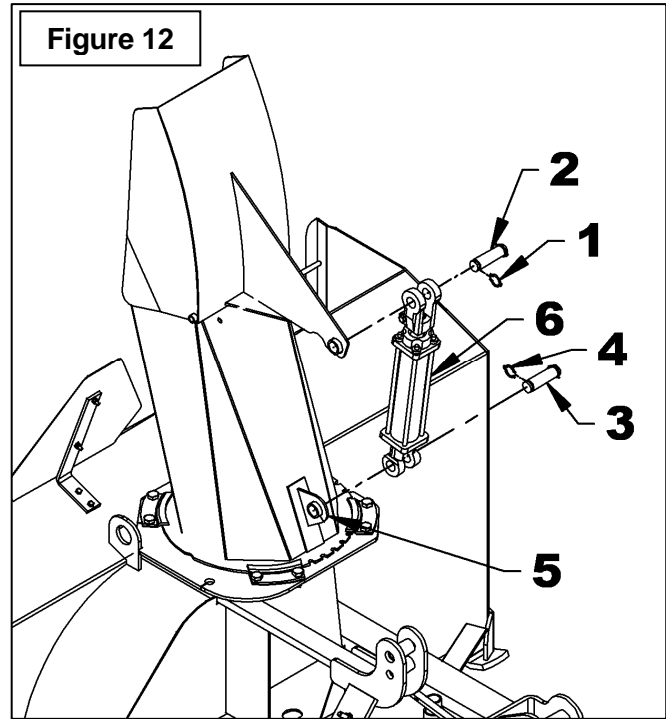

ASSEMBLY

Installation of Electric Deflector Kit 8151 (Figures 14 to 16 & Electrical Diagram)

PRE-ASSEMBLY

- Figure 14A:** Install the clevis with the 1 1/32" diam. hole (item 1) on the actuator base (item 2), and the one with the 1 5/32" diam. hole (item 3) on the other end and attach using two 1/2" NC x 2 1/2" bolts and two 1/2" NC nylon insert locknuts (items 4-5).
- Figure 14A:** Install a 3/16" x 1 3/4" spring pin (item 6) on each 1" pin (item 7).
- Figure 14 & diagram:** Connect the wires to the switch as follows:
 - 72" black ground wire (item 1) to terminal "C" (see diagram).
 - 72" red fuse wire (item 3) to terminal "B" (see diagram).
 - 360" red and black actuator wires (item 4) to terminal "A" and "D" (see diagram).

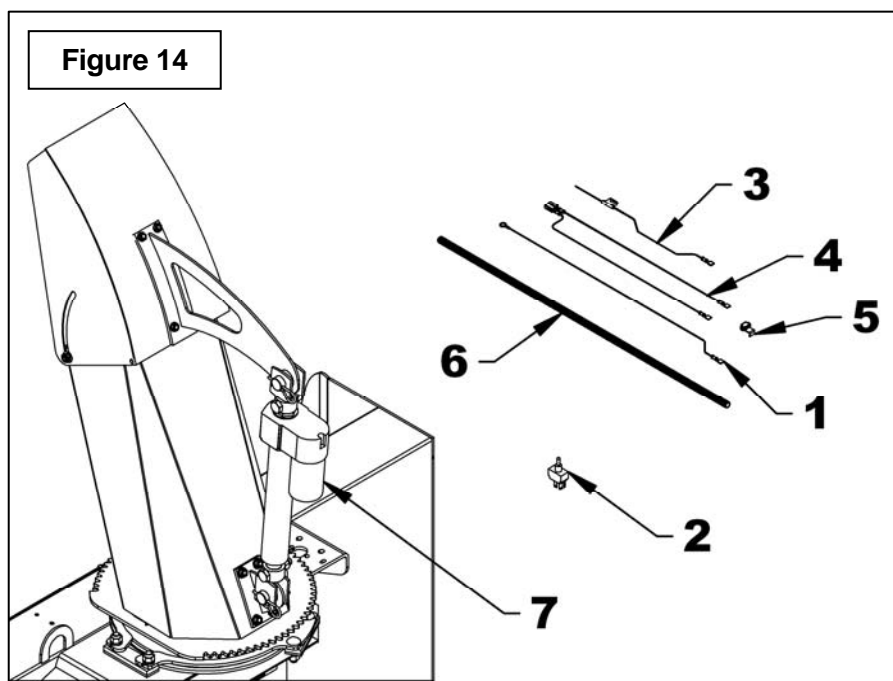
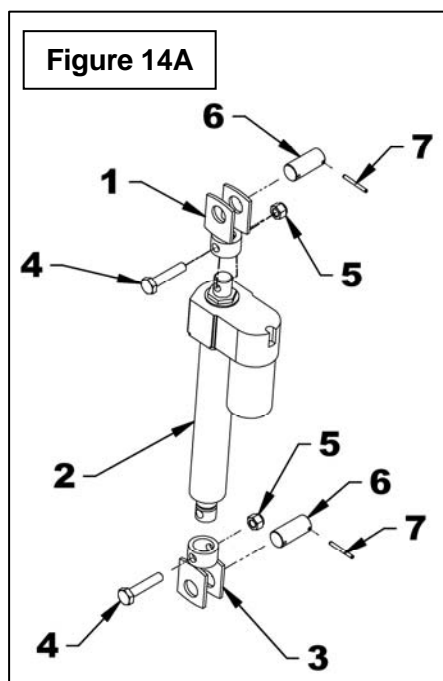
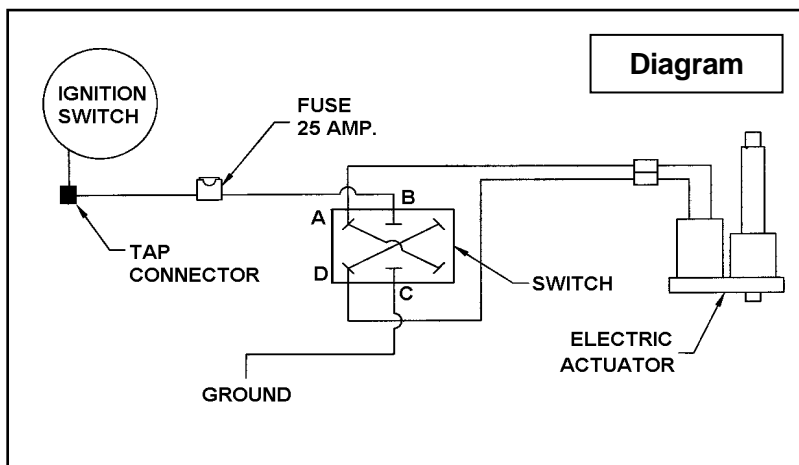

ASSEMBLY

ASSEMBLY

For Chute with knob adjustment:

- 1. Figure 15:** Remove the two manual adjustment knobs and the bolts on each deflector side (item 11) and replace with two 5/16" NC x 3/4" carriage bolts (item 1), the original nylon insert locknuts (item 2) and two 5/16"NC nylon insert locknut (item 3). Leave a 1/16" play.
- 2. Figure :** Place the deflector bracket (item 5) in the middle of the chute deflector, and align with the bottom edge of the deflector. Using the bracket as a template, drill four 1/2" holes in the deflector.
- 3. Figure 15:** Secure in place with four 5/16" NC x 3/4" allen flat head setscrews (item 4) and 5/16" serrated flange nuts (item 6), placing the setscrew head inside the chute. Tighten until the setscrew head sinks into the inside surface of the deflector.

- 4. Figure 15:** Retract completely the pre-assembled actuator rod (item 10). Attach the actuator to the deflector bracket (item 5) and to the base bracket (item 7), with two 1" pins (item 8) and secure with two hairpins (item 9).
- 5. Figure 15:** Open deflector completely, making sure the actuator is completely closed. Place the base bracket (item 7) in the rear center of the chute. Using the bracket as a template, drill four 1/2" holes in the chute.
- 6. Figure 15:** Attach the base bracket with four 5/16" allen flat head setscrews (item 4) and 5/16" serrated flange nuts (item 6) placing the setscrew head inside the chute. Tighten until the setscrew head sinks into the inside surface.

For Chute with telescopic adjustment rod:

- Figure 15A:** Install the pre-assembled actuator (item 10) on the chute in the illustrated position with two 1" pins (item 8) and secure with two 4mm x 80mm hairpins (item 9).

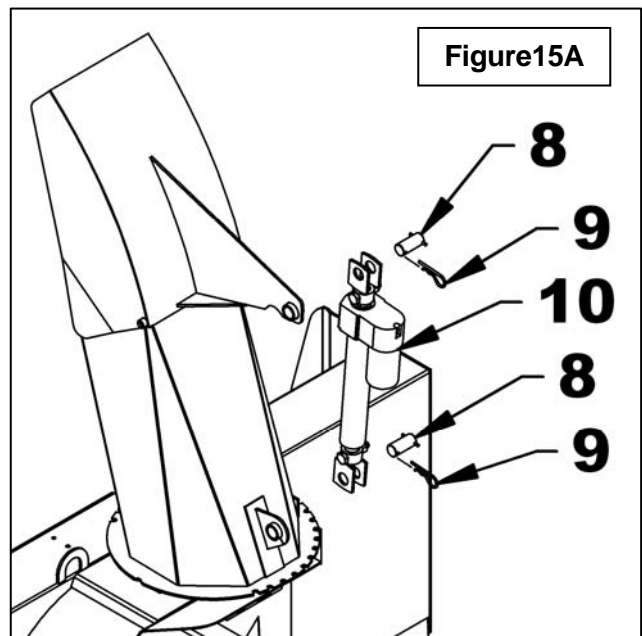
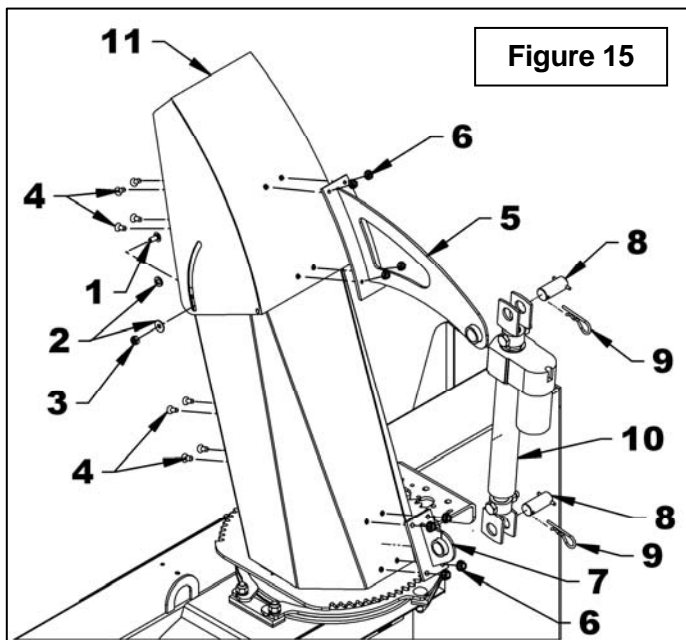

ASSEMBLY

7. **Figure 16:** Insert the switch (item 1) in the switchbox (item 2), secure with the two nuts (items 3) provided with the switch, and screw the rubber cap (item 4) in the order shown on figure. Insert the plastic cap (item 5) in the free hole of the switchbox (if needed).
8. **Figure 16:** Install the switchbox at a convenient location for easy access when operating the snowblower. Secure using three #10 x 1/2" self-drilling screws (item 6). Leave a hole to install the ground wire. Avoid placing the switch box where wires are already installed as they could be damaged.
9. **Figure 14:** Connect the ring terminal of the ground wire (item 1) to a ground screw of the vehicle.
10. **Figure 14:** Connect the fuse wire (item 3) to the tractor switch wire using a tap connector (item 5).
11. **Figure 14:** Connect the actuator double wire (item 4) to the actuator (item 7).
12. **Figure 14:** Cover all wires with the loom (item 6) and attach with tie wrap.

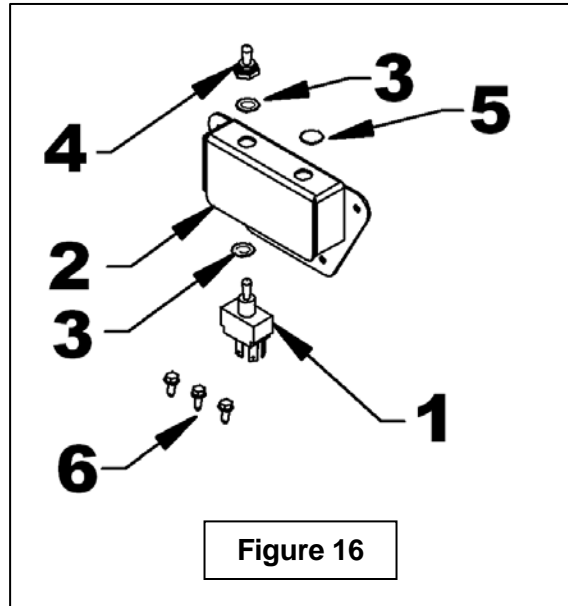

ASSEMBLY

IMPORTANT:

A proper initial installation will give you years of satisfactory service on your equipment. Please read carefully following instructions that have been specially included to help you and ensure you are satisfied with your purchase.



WARNING

Unfortunately, snowblowers will be faced with forgotten or hidden objects under the snow, such as : chain, tires, stones, pieces of wood, etc. In spite of all our efforts, machines are not built to resist all those conditions.

How to Determine Driveline Angles

IMPORTANT: To obtain the proper universal joint angles, it is recommended to adjust the three point hitch at the furthest point from the tractor recommended by the manufacturer

Danger: Tractors Too Big

It is dangerous to use a tractor that is too big and powerful. The tractor will always be able to overload the blower, even if the machine is already at maximum capacity. Furthermore, tractors being very high, the driveline angles will be excessive which means the universal joints will be very vulnerable and the life of the driveline will be dramatically reduced.

The universal joint angle is directly related with the life of driveline. In order to reduce the angle, it is necessary to increase the distance between the snowblower and the tractor.

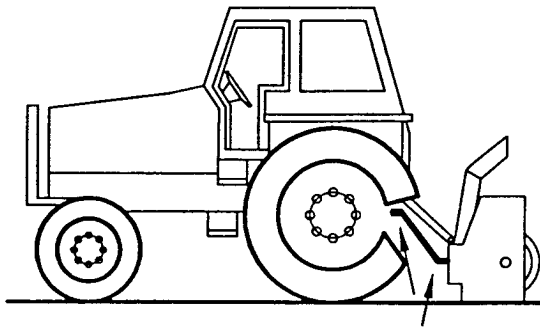

Angles of Driveline Joints Too Large
Avoid

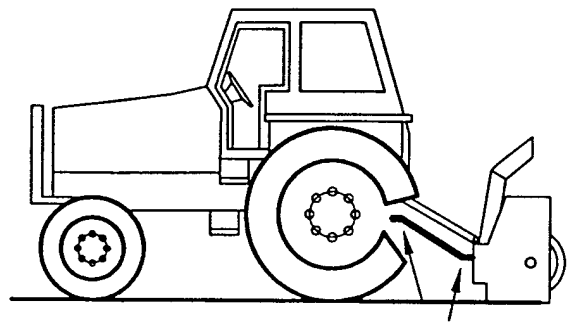

Reasonable Angles of Driveline Joints
Acceptable

ASSEMBLY

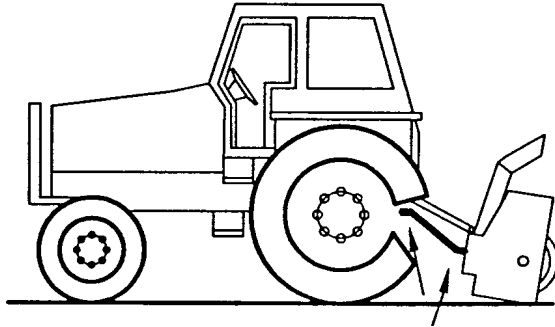

Unequal Angles at Driveline Joints
Avoid

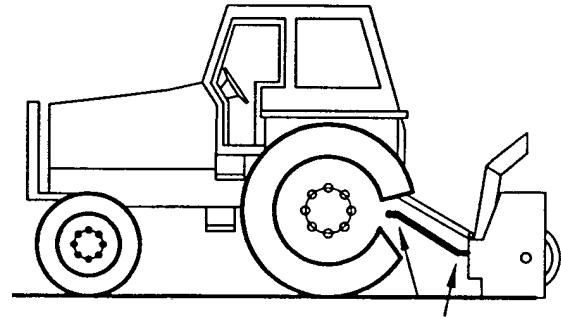

Equal Angles at Driveline Joints
Recommended

Angles at Each End of Driveline

A popular habit is to change the snowblower angle in order to obtain a better scraping effect. This practice can become harmful to the driveline since the angle at each end is unequal. This results in a fan speed variation as well as a drastic increase of load on cross and bearings. To be avoided: It is recommended to always keep tractor driveline and snowblower input shaft parallel.

Determining Driveline Length

IMPORTANT: Before using the equipment, make sure the driveline is not too long. At working position, the two half drivelines must intersect each other sufficiently to insure maximum efficiency but there must not be any interference.

1. To determine the "L" length for your tractor model first find the "X" factor (figure 17) by measuring the horizontal distance between the end of the tractor's drive shaft and the end of the snowblower's driven shaft when the snowblower is in transport position as shown on figure.
2. Choose in the table below the "Y" factor according to the tractor category and deduct that number from "X" (figure 17) to determine "L" (figure 18) which is the center-to-center length between the universal joints.

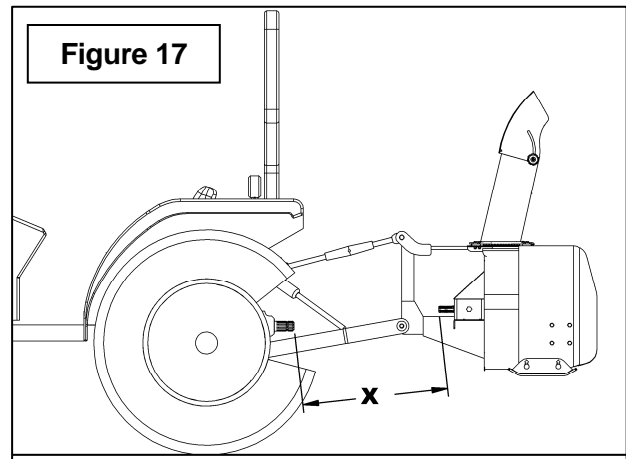

L = X - Y	
3 PTS HITCH CATEGORY	Y
Cat. 1	4 1/2"
Cat. 2	5 1/2"

ASSEMBLY

NOTE: Before cutting, make sure the two shafts intersect by at least 7 3/4" when in working position that is when the snowblower rests on the ground.

3. **Figure 18:** Hold the two half-shaft side by side and locate the "L" length between the two center-to-center half-shaft universal joints. Mark off the zone to be cut on both halves opposite each half-shaft guard as shown on figure.
4. **Figure 18A:** Cut off inner and outer guard tubes as well as the inner and outer telescopic sections.
5. **Figure 18A:** Cut the guard a second time leaving the same distance between the end of the guard and the end of the shaft as existed before. To obtain the proper distance "A" shown on Figure 18A cut the guard according to the following table:

DISTANCE A	
Male PTO	Female PTO
1 3/4"	1 1/4"

6. **Figure 18A:** File down tubes and remove chips.
7. Apply grease to inside of outer telescopic section.

IMPORTANT: Work with fully guarded shafts only.

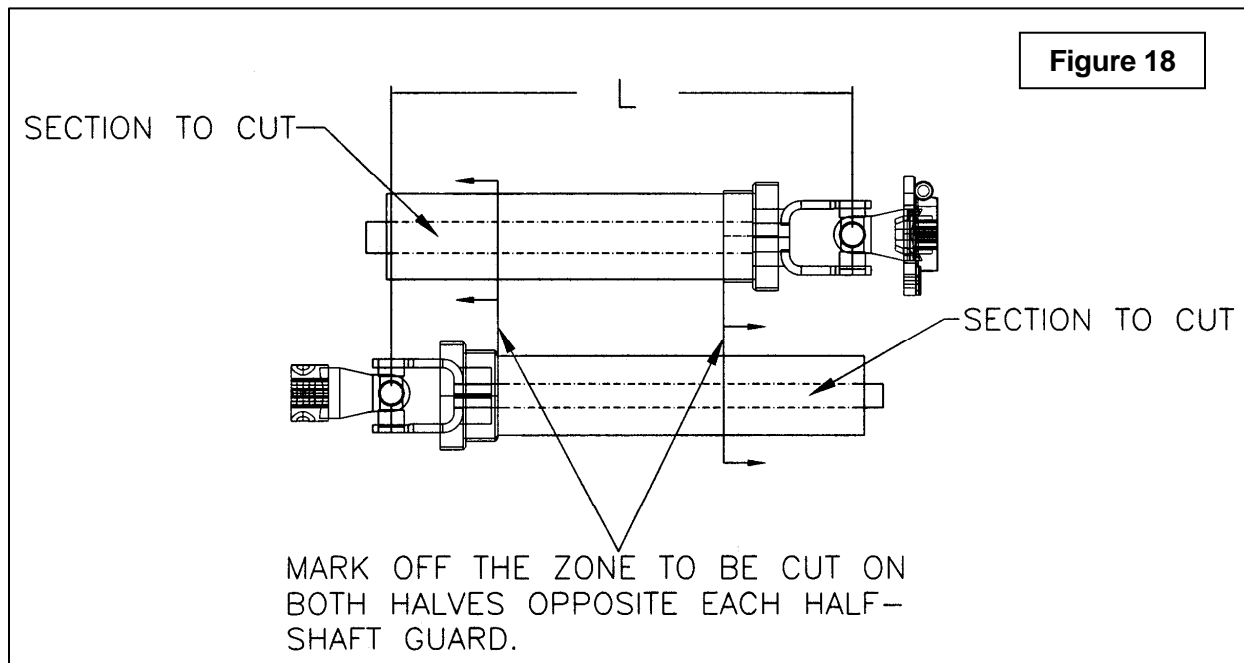
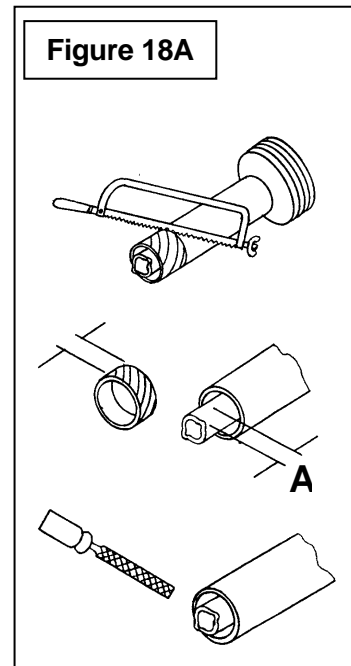

ASSEMBLY

Driveline Installation

(Figure 19)

1. Separate the snowblower from the three point or quick hitch.
2. Remove paint from snowblower gearbox shaft (item 1) and grease driveline sliding surfaces and yoke (item 2).
3. Remove the bolts (items 3) from the driveline yoke (item 2) and slide yoke over drive shaft using the sliding action of the driveline. Make sure the driveline is well secured to the shaft by reinstalling the bolts and nuts (item 3-4) in the order shown. Tighten the bolts according to the **Torque Specification Table** at the end of manual.
4. Attach safety chain (item 5) around the upper link (item 6) to prevent the guard from spinning.

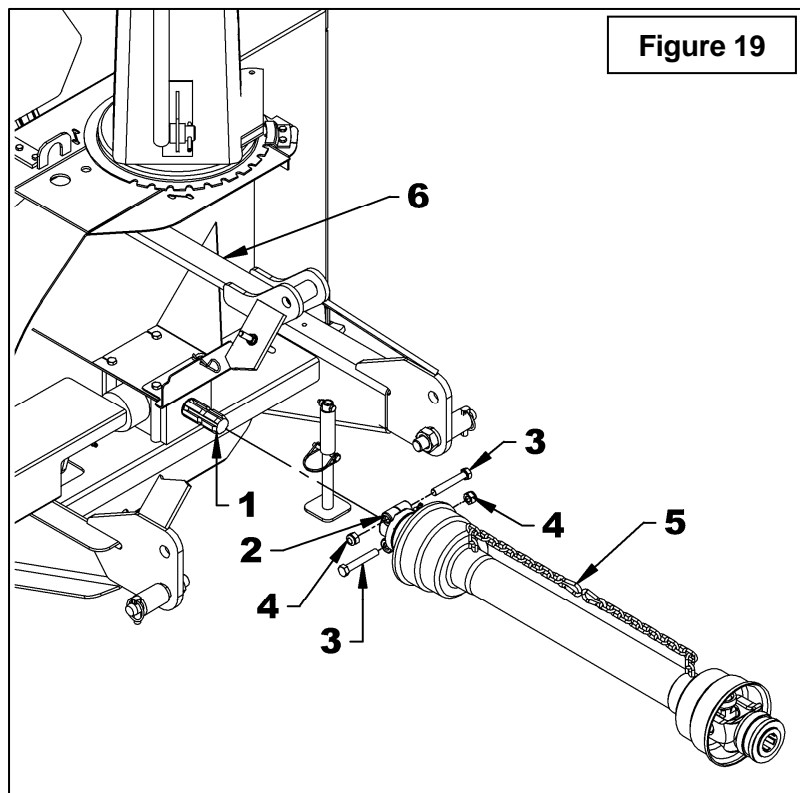

ASSEMBLY

Removing Snowblower from Tractor (Figures 20 à 22)

Three Point Hitch

1. Set parking brake and turn engine off.
2. **Figure 20:** Remove the wire round lock pin (item 2), lower the parking stand (item 1) completely to the ground to release all pressure from the three-point and reinsert the wire round lock pin in the lower hole (item 3).
3. **Figure 21:** Detach upper link (item 4) by removing linchpin and pin (items 6-5).
4. **Figure 21:** Disconnect driveline from tractor and attach the driveline safety chain (item 7) to the three point hitch eyebolt (item 8).
5. **Figure 21:** Carefully detach lower links (items 2) from hitch pins (item 1) by removing linchpins (items 3), loosen anti-sway turnbuckles and slowly back tractor away from the snowblower.

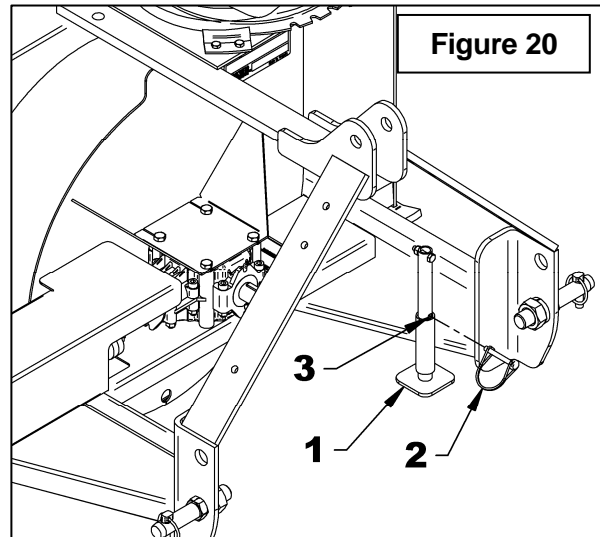

IMPORTANT: To avoid damages to the snowblower, retorque all bolts after the first 10 hours of operation.

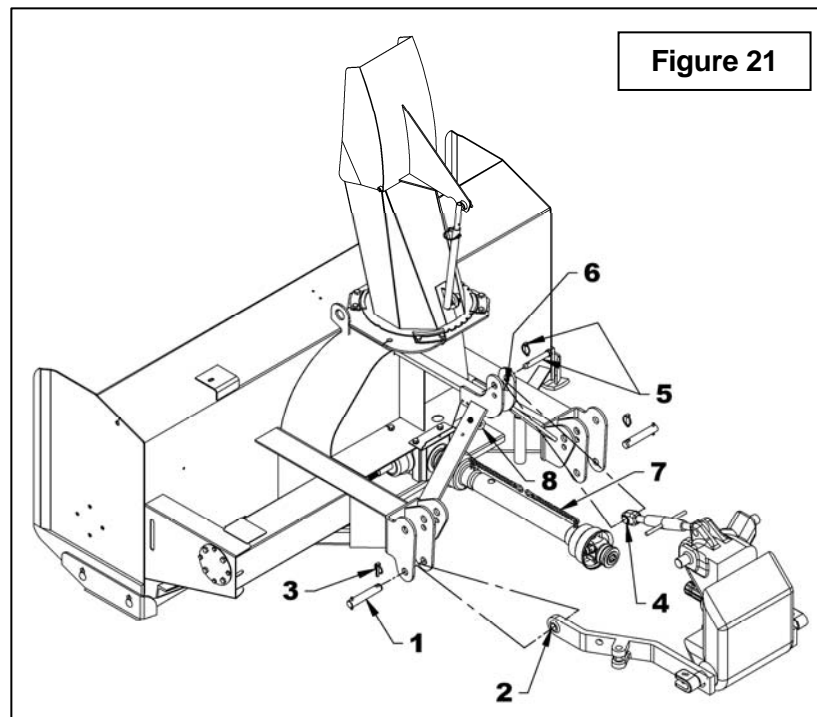

ASSEMBLY

Quick Hitch

1. Set parking brake and turn engine off.
2. **Figure 20:** Remove the wire round lock pin (item 2), lower the parking stand (item 1) and reinsert the wire round lock pin in the lower hole (item 3).
3. **Figure 22:** Disconnect driveline (item 1) from tractor and attach the driveline safety chain (item 2) to the three point hitch eyebolt (item 3).
4. **Figure 22:** Slowly back the tractor away to release quick hitch (item 4) from the snowblower.

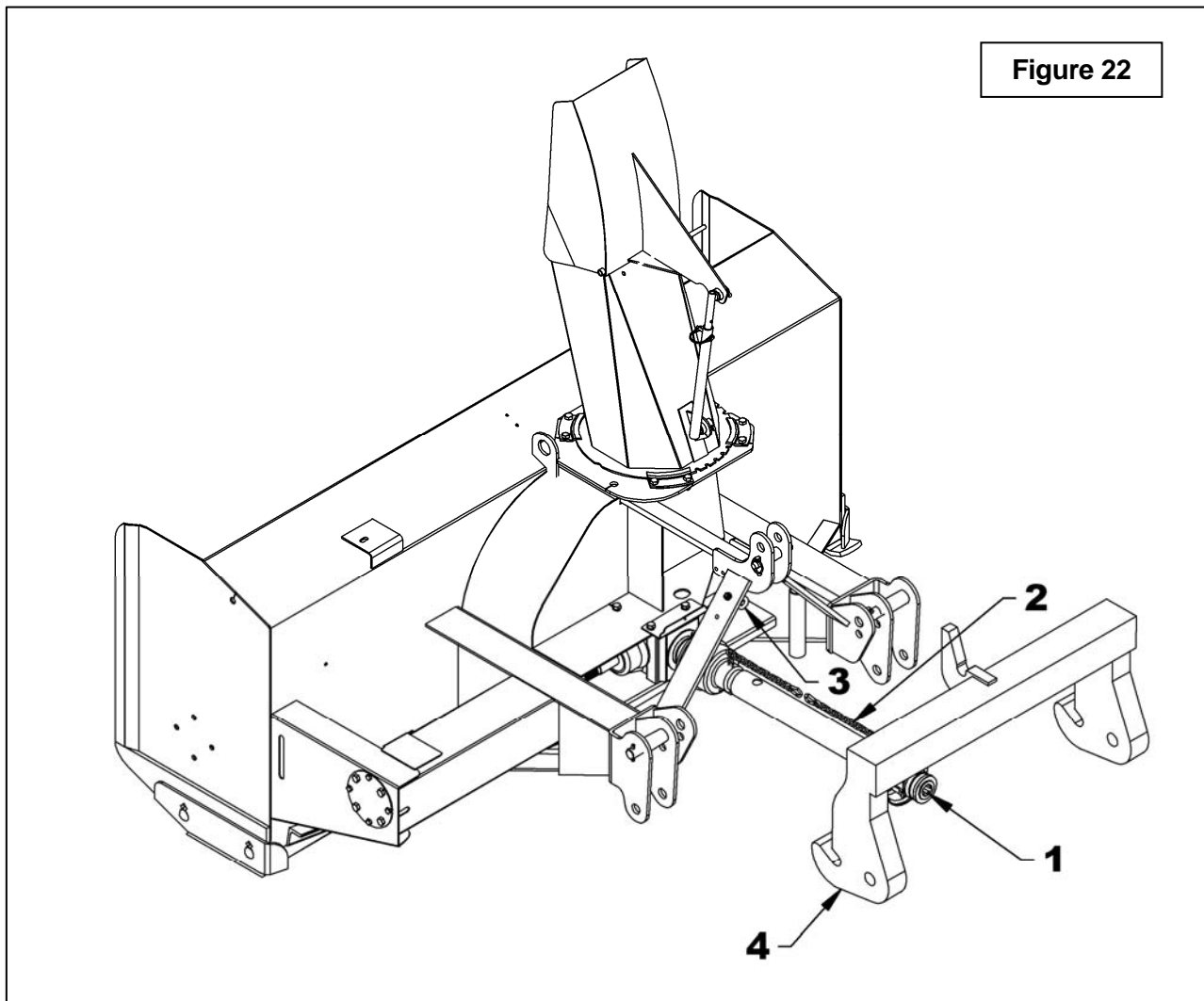

OPERATION

GENERAL PREPARATION

1. Read the operator's manual carefully before using the tractor and snowblower. Be thoroughly familiar with the controls and proper use of the equipment. Know how to stop the unit and disengage the controls quickly.
2. Make sure the snowblower is clear of snow before engaging the driveline.
3. Make sure the auger and fan operate freely.
4. Check the oil level in the worm Gearbox and if necessary, add 80W90 SAE gear oil, AGMA 5EP oil or equivalent.
5. Check the two shear bolts, one on the driving shaft, and the one on the PTO, for proper tightness.
6. Adjust so that the snowblower skid shoes run level.
7. Wear adequate winter outer garments while operating equipment.

OPERATING CONTROLS

Work and Travel Speed

Working ground speed will depend on the depth and density of the snow to be cleared. Normally, ground speed will range from 4 to 7 MPH for light, dry snowfalls 3 to 6 inches, and 1 to 3 MPH for heavy, wet or drifted snow. To transport, disengage the drive shaft and raise the snowblower to full transport height.

Raising and Lowering the Snowblower

Move the three point lever on right hand side of seat down or forward to lower, and up or rearward to raise.



WARNING

To avoid personal injury, be sure the tractor engine is off, the drive shaft disengaged, and all movement has stopped before making any adjustments.

ADJUSTMENTS

Reduction Chain Tension Adjustment (Figure 23)

The premature wear of the chain may be caused by tension being too tight. It is therefore important not to tighten chain to its maximum.

- To adjust the tension on the drive chain, loosen the bolt (item 1), securing the idler sprocket to the snowblower housing.
- To tighten the chain, lower the bolt. Leave approximately 1/8" deflection in one span of the chain. Retighten securely the bolt holding the idler sprocket.

Skid Shoe Adjustment (Figure 23)

Adjust the skid shoes so that the snowblower runs level and according to the surface conditions so that stones are not thrown with the snow.

Adjust both skid shoes to the same height to keep the cutting edge level and adjust upwards for smooth surfaces.

Loosen skid shoe bolts (item 2) and adjust according to instructions below, and securely tighten bolts:

Clearance between cutting edge and surface:

- *Paved surface:* Insert bolts in lower hole.
- *Uneven or gravel surface:* Insert bolts according to distance needed:
 - 1/2" - middle hole
 - 1" - upper hole

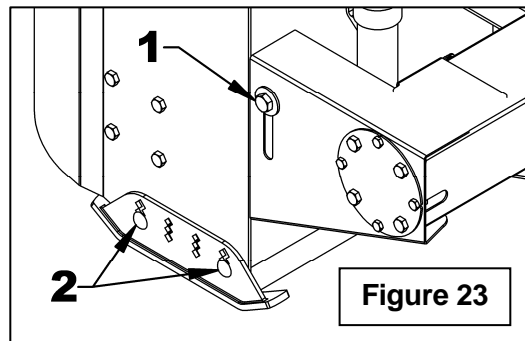

Figure 23

Manual Deflector Adjustment

Set the angle of deflection according to the distance the snow must be thrown. To set the deflector angle, remove the adjusting pipe hairpin and adjust the adjusting rod to the desired deflector angle. Secure with the adjusting pipe hairpin.

OPERATION

SNOW REMOVAL METHODS

When removing snow, do not use the snowblower as a dozer blade to push snow. Let the snowblower work its way through deep drifts. If the speed of your tractor is too fast, the snowblower may become overloaded and clog. For best results, raise the snowblower and remove a top layer of snow. A second pass with the snowblower will remove the remaining snow.

IMPORTANT: Use full RPM power when removing wet, sticky snow. Low RPM power will tend to clog the chute.



Do not use hands or feet to unclog chute. Do not attempt to clear clogged chute of snow while tractor engine is running. If the chute clogs, disengage the drive shaft, shut off the tractor engine, remove the ignition key, wait for all movement to stop, and then clear the snow from the chute.

A definite pattern of operation is required to thoroughly clean the snow area. These patterns will avoid throwing snow in unwanted places as well as eliminating a second removal of snow

PATTERN 1

DISCHARGE SNOW BOTH SIDES

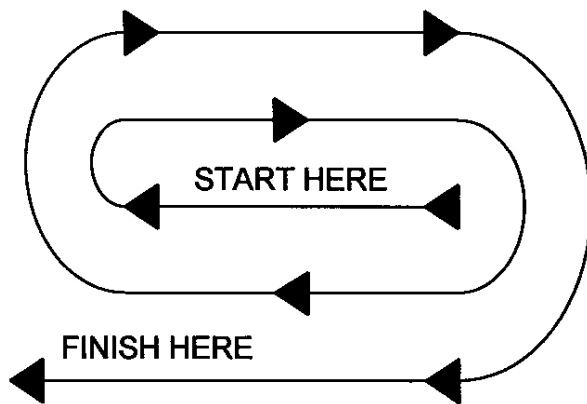

DISCHARGE SNOW BOTH SIDES

PATTERN 2

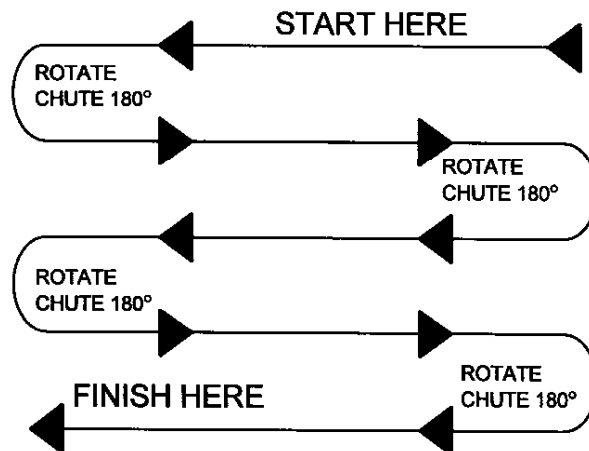

DISCHARGE SNOW THIS SIDE ONLY

Where it is possible to throw the snow to the left and right (above), as on a long driveway, it is advantageous to start in the middle. Plow from one end to the other, throwing snow to both sides without changing the direction of the discharge guide

If the snow can only be thrown to one side of the driveway or sidewalk (above), start on the opposite side. At the end of the first pass, rotate the discharge guide 180 degrees for the return pass. At the end of each succeeding pass, rotate the discharge guide 180 degrees to maintain direction of throw in the same area.

MAINTENANCE

MAINTENANCE

Shearbolts

Check the shearbolts indicated on the figure below at frequent intervals for proper tightness to be sure the blower is in safe working condition. If the shearbolts need replacement, use the following parts only:

Drive shaft:

Shearbolt hex. 5/16" NC x 1 1/4" gr.2 ,
incl. nut. Part # 669345.

Driveline:

Shearbolt M10 x 1.5 x 55 mm gr. 8.8 and
nut. Part # 657199.



WARNING

Provide adequate blocking before working under the snowblower when in the raised position.

Driveline

IMPORTANT: When the snowblower is not used for more than two weeks, perform driveline maintenance and always store it in a dry place, away from bad weather conditions.

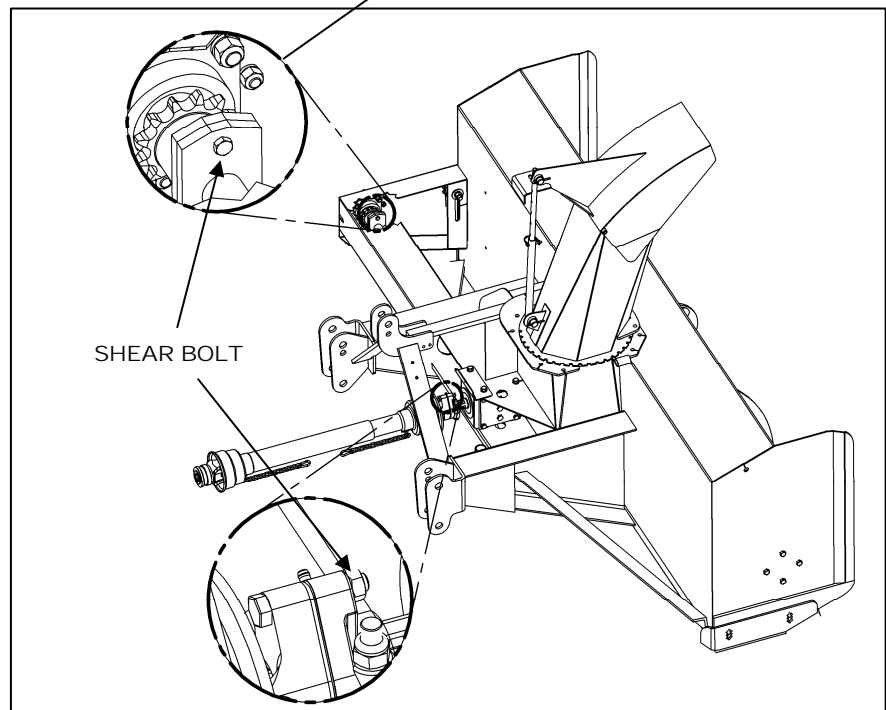
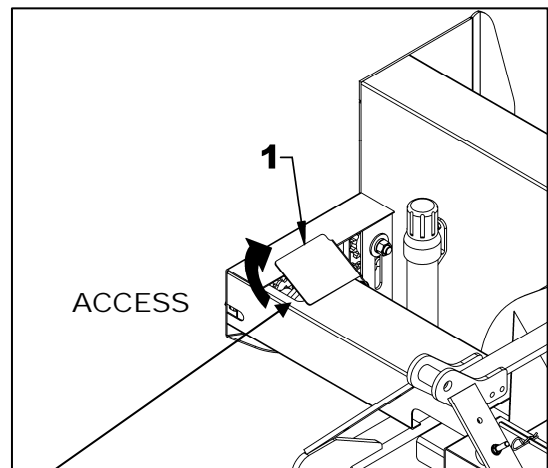

MAINTENANCE

LUBRICATION

Use oil or a grease gun and lubricate as follows:

DESCRIPTION	INTERVAL	LUBRICATION REQUIRED
Driveline	8 hours	Grease each universal joint. Separate the sliding parts and cover each one of them with grease
	16 hours	Oil the push pins
Chain	4 hours and after each operation	Lubricate with chain lube
Drive Shaft	24 hours of operation	Grease fitting on shear plate
Gearbox	Every month	Check oil level. If needed, add AGMA 5EP extreme pressure oil, SAE 80W90 gear oil or equivalent.
	Once a year	Replace oil
Bearing	24 hours of operation	Grease each auger and drive shaft bearing

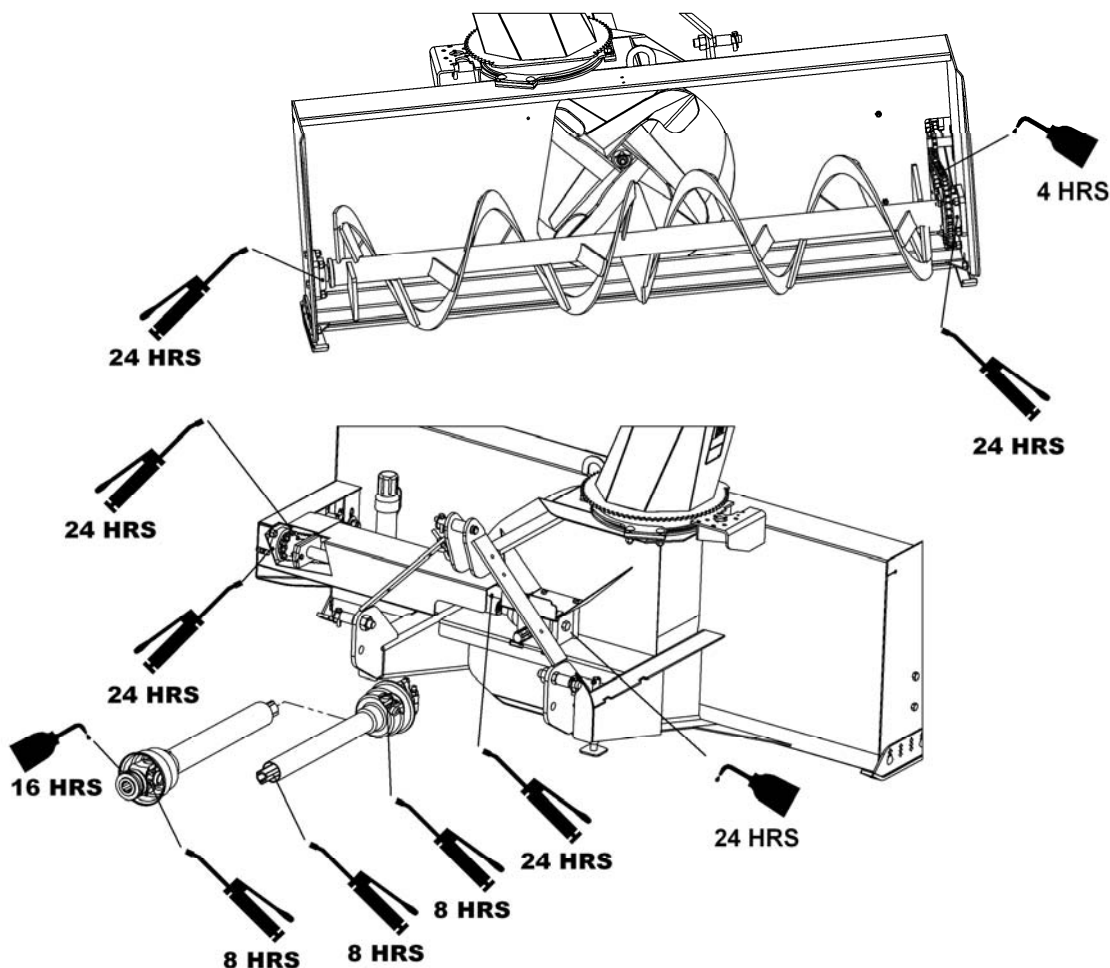

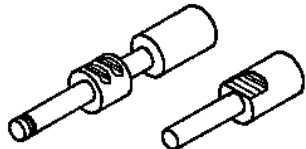

MAINTENANCE

DRIVELINE TROUBLESHOOTING

	AVOIDABLE DAMAGES	POSSIBLE CAUSES	CORRECTIVE ACTIONS
<p><u>QUICK-DISCONNECT YOKE</u></p> 	<ul style="list-style-type: none"> Quick-disconnect pin tight or completely seized. Quick-disconnect pin damaged (broken or bent) Quick-disconnect pin damaged in the locking portion. 	<ul style="list-style-type: none"> Quick-disconnect pin dirty (insufficient maintenance). Quick-disconnect pin defective (forced engagement, incorrect handling) Excessive shaft length. Axial loads too high. 	<ul style="list-style-type: none"> Clean, oil and follow service instructions. Replace quick-disconnect pin. Shorten shaft length (cut both telescopic tubes as well as shield and remove burrs). Replace quick-disconnect pin. Clean and grease telescopic tubes, and replace both tubes, if necessary. Replace quick-disconnect pin.

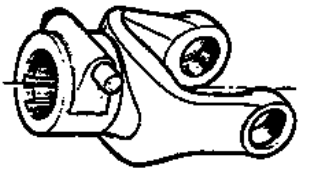

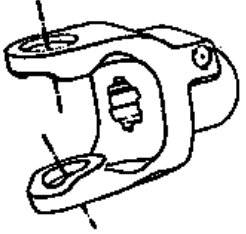
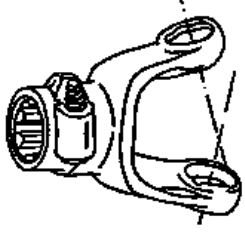
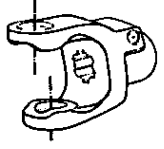
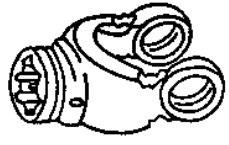

Note: Quick-disconnect pins must be cleaned and greased every 16 hours.

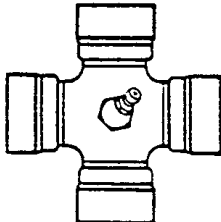
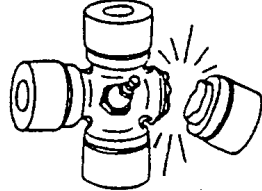
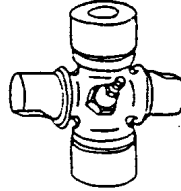
	AVOIDABLE DAMAGES	POSSIBLE CAUSES	CORRECTIVE ACTIONS
<p><u>YOKE</u></p>   	<ul style="list-style-type: none"> Yoke ears deformation  	<ul style="list-style-type: none"> Excessive shaft length. Axial loads too high. Excessive working angle and torque. 	<ul style="list-style-type: none"> Shorten shaft length (cut both telescopic tubes as well as shields and remove burrs). Replace defective yokes. Clean and grease telescopic tubes, and replace both tubes, if necessary. Replace defective yokes. Verify compatibility between shaft and working conditions (torque vs. angle). Disengage tractor driveline during cornering or when lifting or lowering the implement. Change to a larger driveline size. Replace defective yokes.
	<ul style="list-style-type: none"> Yoke ears distorted. 	<ul style="list-style-type: none"> Overload caused by high starting and peak torques. 	<ul style="list-style-type: none"> Engage driveline more carefully. Use appropriate safety devices. Replace defective yokes.
	<ul style="list-style-type: none"> Yoke ears worn or pounded. 	<ul style="list-style-type: none"> Excessive working angle. 	<ul style="list-style-type: none"> Avoid excessive working angle. Disengage tractor driveline during cornering. Replace defective yokes.

MAINTENANCE

	AVOIDABLE DAMAGES	POSSIBLE CAUSES	CORRECTIVE ACTIONS
<p><u>CROSS KIT</u></p> 	<ul style="list-style-type: none"> ◆ Cross arms broken. 	<ul style="list-style-type: none"> ◆ Extreme torque peak or shock load. ◆ Axial loads too high. 	<ul style="list-style-type: none"> ◆ Use appropriate safety device. ◆ Change to a larger driveline size. ◆ Shorten driveline shaft. ◆ Replace defective cross bearings.
	<ul style="list-style-type: none"> ◆ Bearing caps turning in their cross journal. ◆ Overheated bearing caps. 	<ul style="list-style-type: none"> ◆ Excessive continuous torque and/or excessive working angle. ◆ Inadequate greasing. 	<ul style="list-style-type: none"> ◆ Verify compatibility between shaft and working conditions. ◆ Carefully follow greasing instructions. ◆ Replace defective cross bearings.
	<ul style="list-style-type: none"> ◆ Accelerated wear of cross kit. 	<ul style="list-style-type: none"> ◆ Excessive continuous torque and/or excessive working angle. ◆ Inadequate greasing. 	<ul style="list-style-type: none"> ◆ Verify compatibility between shaft and working conditions. ◆ Carefully follow greasing instructions. ◆ Replace defective cross bearings.

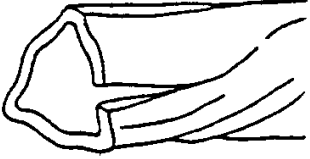
Note: Cross bearings must be greased every 8 working hours.

	AVOIDABLE DAMAGES	POSSIBLE CAUSES	CORRECTIVE ACTIONS
<p><u>TELESCOPIC TUBES</u></p>  	<ul style="list-style-type: none"> ◆ Telescopic tubes failure or twisting. 	<ul style="list-style-type: none"> ◆ Extreme torque peak or shock load. ◆ Short tube engagement. 	<ul style="list-style-type: none"> ◆ Use appropriate safety device. ◆ Change to a larger driveline size. ◆ Replace the driveline drive shaft with one having adequate length. ◆ Replace defective tubes.
	<ul style="list-style-type: none"> ◆ Accelerated wear of telescopic tubes. 	<ul style="list-style-type: none"> ◆ Extreme load when sliding. ◆ Short tube engagement. ◆ Inadequate greasing. ◆ Dirt 	<ul style="list-style-type: none"> ◆ Change to a driveline with rilsan coated inner tube. ◆ Replace the driveline with one having adequate length. ◆ Carefully follow greasing instructions. ◆ Replace defective tubes.

Note: Telescopic tubes must be cleaned and greased every 8 working hours.

MAINTENANCE

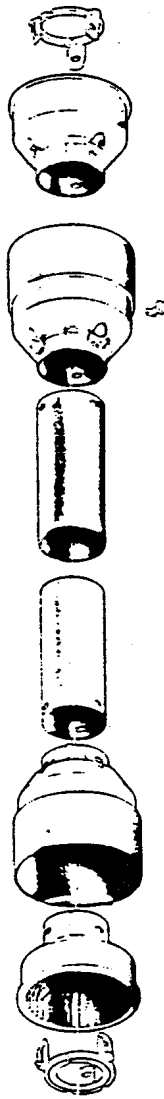
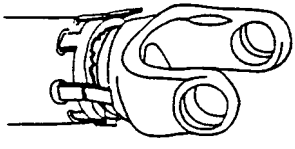
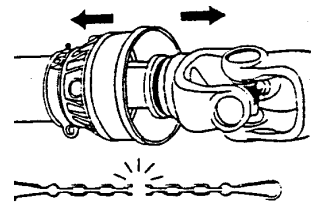
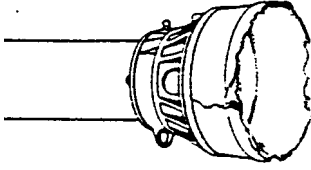
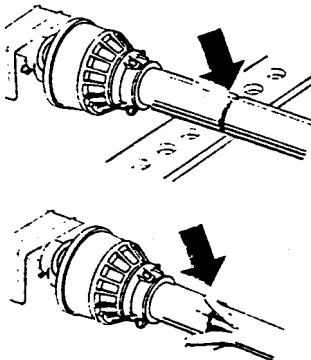
	AVOIDABLE DAMAGES	POSSIBLE CAUSES	CORRECTIVE ACTIONS
<p>SHIELD</p> 	<ul style="list-style-type: none"> ◆ Excessive wear of shield bearings. 	<ul style="list-style-type: none"> ◆ Insufficient lubrication. ◆ Incorrect chain mounting. ◆ Shield interfering with implement. 	<ul style="list-style-type: none"> ◆ Follow lubrication instructions. ◆ Mount chain to allow maximum angularity. ◆ Avoid contact of the shields with fixed parts of the machine or tractor. ◆ Replace shield bearings.
	<ul style="list-style-type: none"> ◆ Chain moving or failure. 	<ul style="list-style-type: none"> ◆ Shield interfering with implement. ◆ Incorrect chain mounting. 	<ul style="list-style-type: none"> ◆ Avoid contact of the shields with fixed parts of the machine or tractor. ◆ Mount chain to allow maximum angularity. ◆ Replace defective parts.
	<ul style="list-style-type: none"> ◆ Shield cone damaged. 	<ul style="list-style-type: none"> ◆ Shield cone in contact with components on the tractor and/or implement. ◆ Excessive angularity. 	<ul style="list-style-type: none"> ◆ Eliminate interference between Shield cones and any part on the tractor and/or implement. ◆ Avoid excessive angle during cornering or when lifting or lowering the implement. ◆ Replace damaged Shield cones.
	<ul style="list-style-type: none"> ◆ Shield tubes damaged (deformed and split at one side). 	<ul style="list-style-type: none"> ◆ Shields in contact with components on the tractor and/or implement. ◆ Shield tubes overlap too short or no overlap at all with extended driveline. 	<ul style="list-style-type: none"> ◆ Eliminate interference between Shield cones and any part on the tractor and/or implement. ◆ Replace damaged tubes. ◆ Adjust Shield tubes length with longer tubes.

Note: Shield bearings must be greased every 8 working hours.

PARTS

INTRODUCTION

All parts are illustrated in "exploded views" which show the individual parts in their normal relationship to each other. Reference numbers are used in the illustrations. These numbers correspond to those in the "Reference Number" (REF) column, and are followed by the description and quantity required.

Right Hand and Left Hand are determined by those seen by the conductor standing behind the equipment.

The manufacturer reserves the rights to change, modify, or eliminate from time to time, for technical or other reasons, certain or all data, specifications, or the product or products themselves, without any liability or obligation.

The parts listed here are available through your local dealer.

MANUAL HOLDER – ALL MODELS

REF.	DESCRIPTION	QTY	PART #
1	Manual holder	1	4200030
2	Bolt hex. 5/16" NC x 3/4" lg gr. 5, PTD	2	0100018
3	Nut nylon insert 5/16" NC, PTD	2	1000005

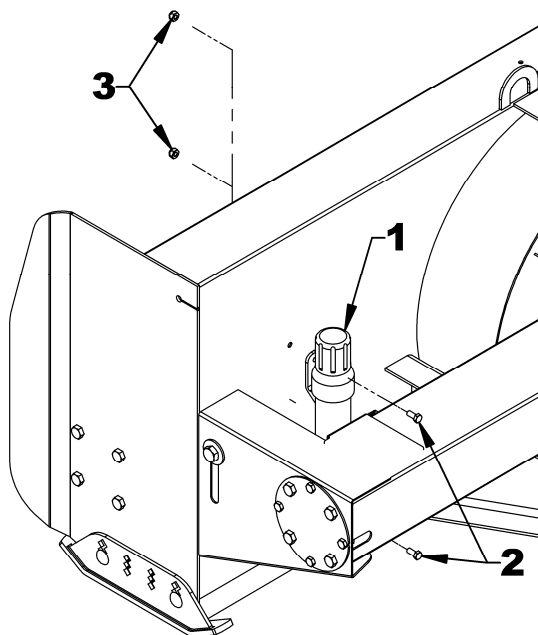

PARTS

SNOWBLOWER – B84 & B94

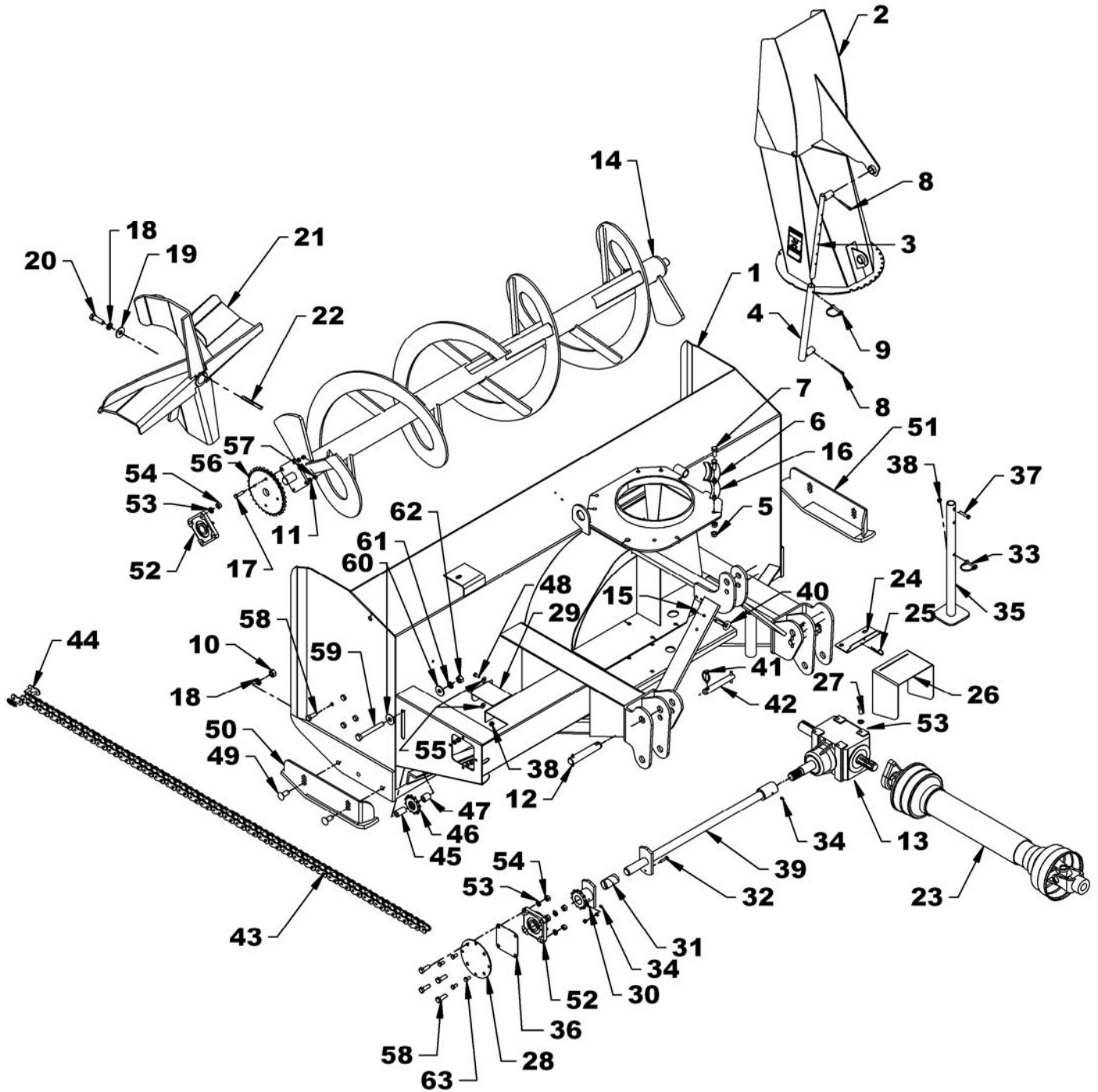

PARTS

SNOWBLOWER – B84 & B94

REF.	DESCRIPTION	QTY	PART #
1	Housing	1	---
2	Chute assembly (including adjustment tube and rod)	1	668101
3	Adjustment rod	1	654074
4	Adjustment tube	1	654076
5	Serrated flange nut 1/2" NC PTD	8	0900046
6	Retaining plate	4	654197
7	Bolt hex. 1/2" NC x 1 1/4" gr.5 PTD	8	0100069
8	Cotter pin 1/4" x 2" PTD	2	1500022
9	Round wire lock pin 1/4" x 2" PTD	1	1900006
10	Nut hex. 5/8" NC PTD	4	0900007
11	Lockwasher 3/8" PTD	8	1200004
12	Hitch pin 1 1/8" x 6 1/4" lg Cat. 2	2	4600042
13	Gearbox	1	662195
14	Auger – B84	1	666278
	Auger – B94	1	666290
15	Serrated flange nut 3/8" NC PTD	1	0900035
16	Bushing 1 1/4" OD x 1 7/8" lg	1	668058
17	Bolt hex. 3/8" NC x 1 1/2" gr.5 PTD	4	0100040
18	Lockwasher 5/8" PTD	5	1200007
19	Flat washer 5/8" (11/16" dia. hole) PTD	1	1400008
20	Bolt hex. 5/8" NC x 2" gr.5 PTD	1	0100095
21	Fan	1	668967
22	Key 3/8" x 3/8" x 4" lg	1	4500075
23	Driveline Series 50 – B84	1	662194
	Driveline Series 60 – B94	1	662538
24	Driveline shield bracket	1	668449
25	Hairpin 3mm x 65mm lg PTD	1	1800004
26	Driveline shield	1	668057
27	Bolt hex. 1/2" NC x 1" gr.5 PTD	8	0100068
28	Driving shaft support	1	669356
29	Access plate	1	669597
30	Shear plate	1	669344
31	Oilite bushing	1	4300072
32	Shearbolt 5/16"NC x 1 1/4" gr.2, incl. nut	1	669345
33	Square wire lock pin 3/8" x 2 1/2"	1	1900008
34	Grease fitting 1/4" NF	2	654106
35	Parking stand	1	668091
36	Spacer plate	1	669722
37	Bolt hex. 5/16" NC x 1 3/4" gr. 5 PTD	1	0100022
38	Nylon insert hex. nut 5/16" NC PTD	2	1000005

PARTS

SNOWBLOWER – B84 & B94

REF.	DESCRIPTION	QTY	PART #
39	Driving shaft – B84	1	669621
	Driving shaft – B94	1	669622
40	Eyebolt 3/8" NC x 4" lg inc. nut	1	0400027
41	Linchpin 7/16" PTD	3	1900003
42	Hitch pin 7/8" x 6 1/4" lg Cat. 1	2	4600043
43	Chain #60H x 94 links, w/connecting link	1	655788
44	Connecting link #60H	1	662029
45	Spacer ring .656"ID x 1.760 x 1" ext.	1	668093
46	Idler sprocket 60A12	1	3300022
47	Spacer ring .656"ID x 1.151 lg x 1" ext.	1	668094
48	Bolt hex. 5/16"NC x 3/4" lg gr.5 PTD	1	0100018
49	Bolt carriage 5/8" NC x 1 1/2" lg gr.5 PTD	4	0300043
50	Left adjustable skid shoe	1	666287
51	Right adjustable skid shoe	1	666288
52	Flange bearing 1 1/4" hole, 4 holes	3	4300001
53	Lockwasher 1/2" PTD	20	1200006
54	Nut hex. 1/2" NC PTD	12	0900006
55	Nylon flat washer 11/32" hole	2	658467
56	Sprocket 60A32	1	654167
57	Nut hex 3/8" NC gr.5 PTD	8	0900003
58	Bolt hex. 1/2" NC x 1 1/2" lg gr.5 PTD	12	0100070
59	Bolt hex. 5/8" NC x 5" lg gr.5 PTD	1	0100105
60	Flat washer 5/8" (11/16" dia. hole)	2	1400008
61	Lockwasher 5/8" PTD	1	1200007
62	Nut hex. 5/8" NC gr.5 PTD	1	0900007
63	Bolt hex. 3/8" NC x 3/4" lg gr.5 PTD	4	0100037
64	Spacer	4	668549

PARTS

GEARBOX 662195 FOR B84 & B94

REF.	DESCRIPTION	QTY	PART #
1	Casing	1	656640
2	Seal kit 35 x 72 x 10	1	659845
3	External retaining ring	1	656652
4	Spacer	2	656649
5	Bearing flange	1	659844
6	Spacer	1	656648
7	Internal retaining ring	1	656654
8	Bearing flange	1	656647
9	Shaft	1	656651
10	Gear	1	656645
11	External retaining ring	1	656646
12	Bearing flange	2	656641
13	Spacer	1	656644
14	Internal retaining ring	2	656642
15	Seal kit 40 x 80 x 12	2	656643
16	Shaft	1	662212
17	Gear	1	656657
18	Spacer	1	661146
19	Plug	1	656662
20	Cover	1	656660
21	Bolt hex. M10 x 14 gr.8.8	4	656659
22	Plug 3/8" NPT	2	655259

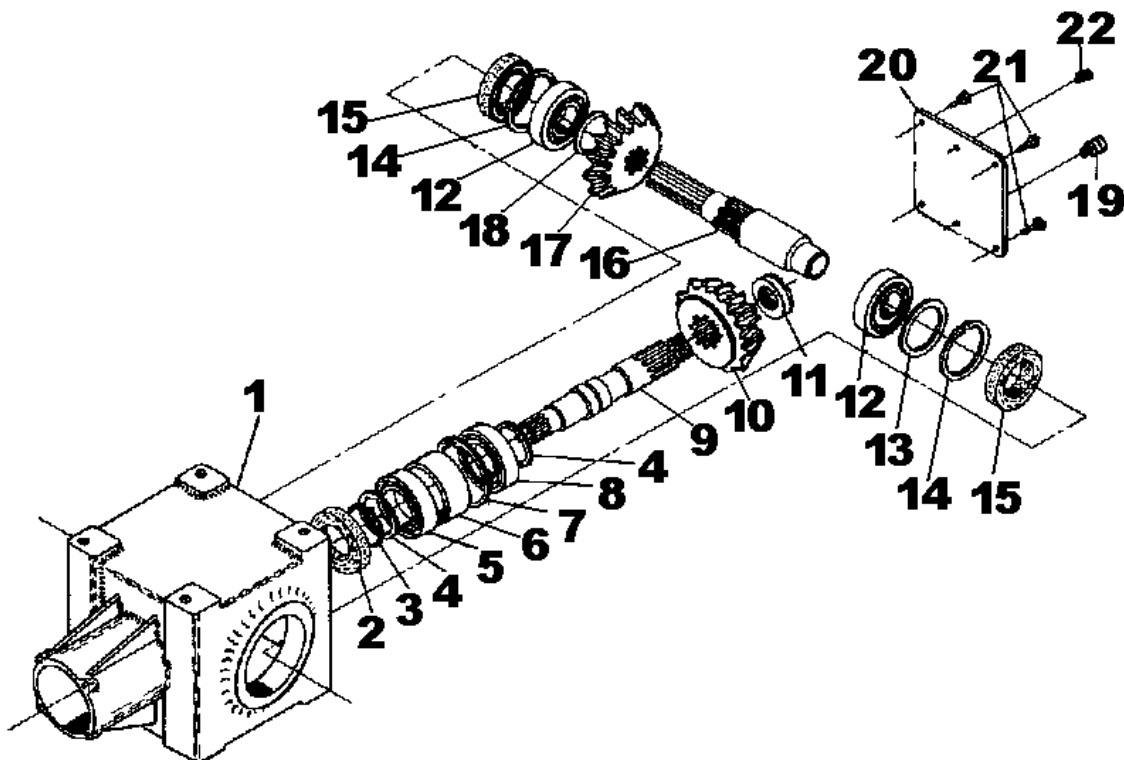

PARTS

DRIVELINE 662194 FOR B84

REF.	DESCRIPTION	QTY.	PART #
1	Push pin yoke assembly	1	657209
2	Journal cross	2	657200
3	Outer yoke	1	663119
4	Outer tube	1	663123
5	Inner tube	1	663124
6	Inner yoke	1	663126
7	Yoke and hub assembly	1	662198
8	Bolt and nut	2	662199
9	Grease fitting	1	663129
10	Ball Ø14"	23	663163
11	Shear bolt and nut, M10 x 1.5 x 55 mm gr. 8.8 PTD	1	657199
12	Shields with safety chain	1	657221
13	Pin for male tube	1	663125
14	Pin for female tube	1	663120

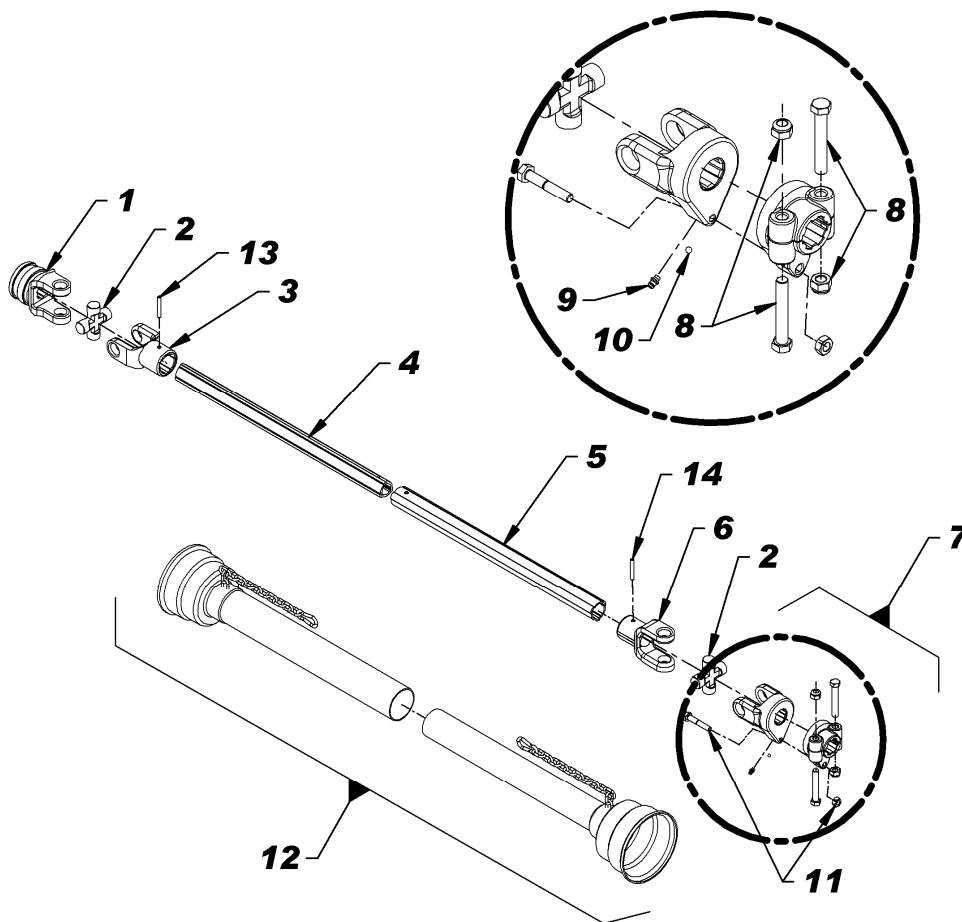

PARTS

DRIVELINE 662538 FOR B94

REF.	DESCRIPTION	QTY	PART #
1	Quick disconnect yoke assembly - slide collar	1	4700083
2	Universal joint kit	2	663134
3	Outer yoke	1	663136
4	Outer tube	1	663140
5	Inner tube	1	663142
6	Inner yoke	1	663144
7	Yoke and hub assembly	1	663145
8	Bolt and nut	2	662199
9	Grease fitting	1	663148
10	Ball	24	663162
11	Shear bolt and nut, M10 x 1.5 x 55 mm gr. 8.8 PTD	1	657199
12	Shields with safety chain	1	663150
13	Outer circlip	1	4700084
14	Sliding sleeve collar	1	4700085
15	Spring	1	4700086
16	Fixed sleeve	1	4700087
17	Ball 1/2"	3	4700088
18	Roll pin for outer tube	1	663153
19	Roll pin for inner tube	1	663157

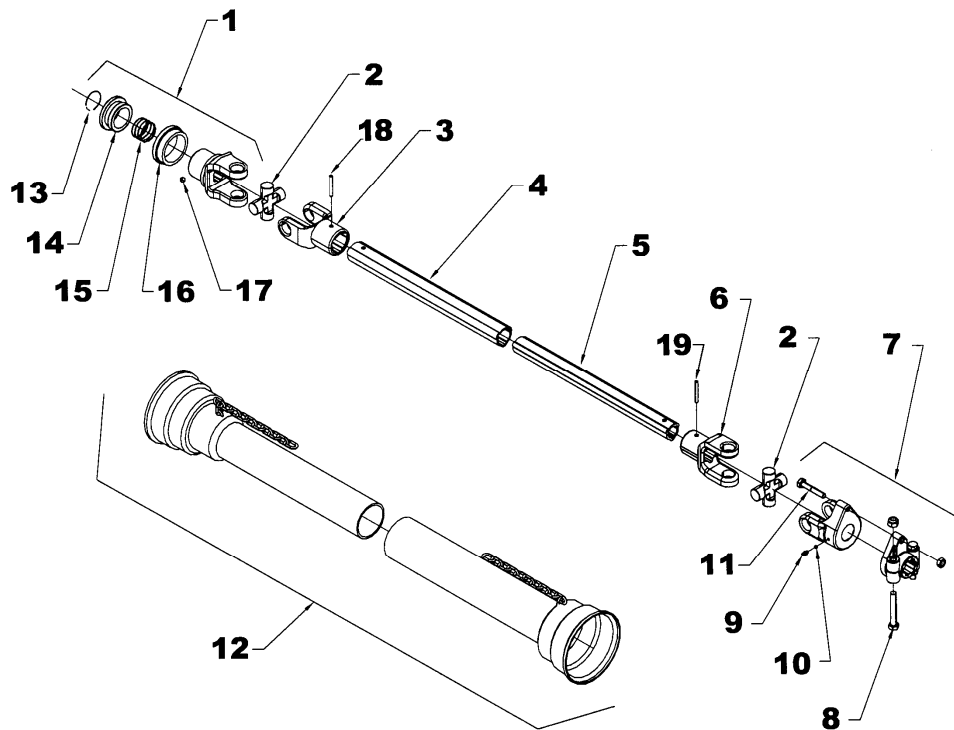

PARTS

8046 - HYDRAULIC ROTATION

REF.	DESCRIPTION	QTY	PART #
1	Rotation bracket	1	664475
2	Bell crank	1	664473
3	Push arm	1	664474
4	Flat washer 1 1/16" hole PTD	1	1400013
5	Spacer ring	1	664477
6	Pivot bushing	1	664476
7	Bolt hex. 3/4" NC x 4", gr. 5 PTD (For B74 only)	1	0100124
8	Bolt hex. 1/2" NC x 1 1/4", gr. 5 PTD	1	0100069
9	Bolt hex. 3/4" NC x 5", gr. 5 PTD (For B84 & B94)	1	0100126
10	Shoulder screw 1/2" x 1" lg 3/8"NC	2	664578
11	Nut hex. 3/4" NC PTD	1	0900008
12	Nut serrated flange 1/2" NC PTD	1	0900046
13	Stover nut hex 3/8" NC PTD	2	1100003
14	Lockwasher 3/4" PTD	1	1200008
15	Flat washer 3/8" hole PTD	2	1400003
16	Flat washer 9/16" hole PTD	3	1400006
17	Decal "Danger"	1	664548

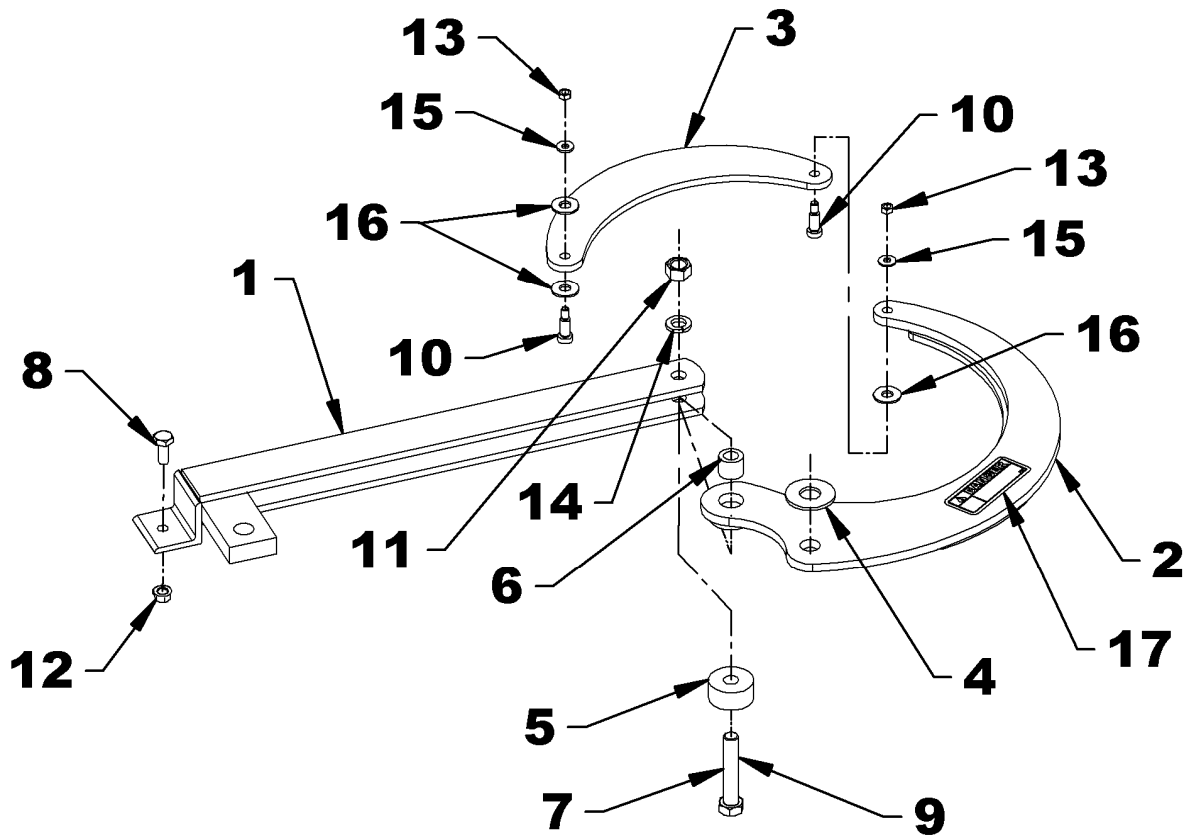

PARTS

8249 - CYLINDER FOR HYDRAULIC DEFLECTOR

REF.	DESCRIPTION	QTY	PART #
1	Cylinder 2" X 8" inc. pins	1	390022
	Seal kit	1	3900205

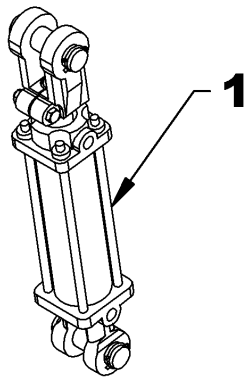

PARTS

8151- ELECTRIC DEFLECTOR

REF.	DESCRIPTION	QTY	PART #
1	Actuator	1	662983
2	Switchbox	1	666048
3	Switch	1	663383
4	Rubber cap	1	658666
5	Plastic cap	1	662530
6	Clevis – rod	1	666049
7	Clevis – base	1	666050
8	Pin 1"	2	666057
9	Ground wire 72" (black)	1	666054
10	Tap connector	1	656665
11	Fuse wire 72" (red)	1	666055
12	Actuator wire assembly	1	666056
13	Spring pin 3/16" x 1 3/4", black	2	1600009
14	Hairpin 4mm x 80mm, PTD	2	1800002
15	Self-drilling screw #10 x 1/2"	4	3200011
16	Bolt hex. 1/2"NC x 2 1/2", PTD	2	0100076
17	Nylon insert locknut 1/2"NC, PTD	2	1000011
18	Loom 3/8" x 420"	1	666053
19	Nylon insert locknut 5/16"NC, PTD	2	1000005
20	Nylon insert locknut 8" lg x 4 mm	5	2100003
21	Deflector bracket	1	669826
22	Base bracket	1	669825
23	Allen setscrew, flat head 5/16"NC x 3/4"	8	0700003
24	Serrated flange nut 5/16"NC, PTD	8	0900036
25	Carriage bolt 5/16"NC x 3/4" PTD	2	0300002

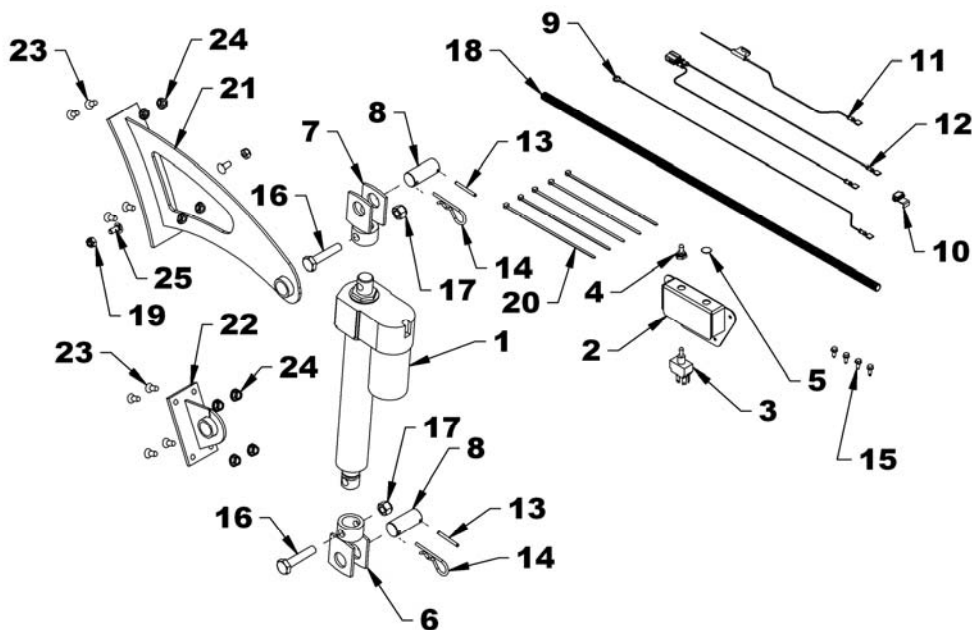







TORQUE SPECIFICATION TABLE

























GENERAL SPECIFICATION TABLE

Use the following torques when special torques are not given

NOTE: These values apply to fasteners as received from supplier, dry, or when lubricated with normal engine oil. They do not apply if special graphited or moly sidulphide greases or other extreme pressure lubricants are used. This applies to both UNF and UNC threads.

SEE Grade No.		2				5				8			
BOLT HEAD IDENTIFICATION MARKS AS PER GRADE NOTE: MANUFACTURING MARKS WILL VARY.						  				  			
BOLT SIZES		Torque				Torque				Torque			
Inches	Millimeters	Pounds-Foot		Newtons-Meter		Pounds-Foot		Newtons-Meter		Pounds-Foot		Newtons-Meter	
		MIN.	MAX.	MIN.	MAX.	MIN.	MAX.	MIN.	MAX.	MIN.	MAX.	MIN.	MAX.
1/4	6.35	5	6	6.8	8.13	9	11.0	12.2	14.9	12	15	16.3	30.3
5/16	7.94	10	12	13.6	16.3	17	20.5	23.1	27.8	24	29	32.5	39.3
3/8	9.53	20	23	27.1	31.2	35	42.0	47.5	57.0	45	54	61.0	73.2
7/16	11.11	25	30	40.7	47.4	54	64.0	73.2	86.8	70	84	94.9	113.9
1/2	12.70	45	52	61.0	70.5	80	96.0	108.5	130.2	110	132	149.2	179.0
9/16	14.29	65	75	88.1	101.6	110	132.0	149.2	179.0	160	192	217.0	260.4
5/8	15.88	95	105	128.7	142.3	150	180	203.4	244.1	220	264	298.3	358.0
3/4	19.05	150	185	203.3	250.7	270	324	366.1	439.3	380	456	515.3	618.3
7/8	22.23	160	200	216.8	271.0	400	480	542.4	650.9	600	720	813.6	976.3
1	25.40	250	300	338.8	406.5	580	696	786.5	943.8	900	1080	1220.4	1464.5
1 1/8	25.58	-	-	-	-	800	880	1084.8	1193.3	1280	1440	1735.7	1952.6
1 1/4	31.75	-	-	-	-	1120	1240	1518.7	1681.4	1820	2000	2467.9	2712.0
1 3/8	34.93	-	-	-	-	1460	1680	1979.8	2278.1	2380	2720	3227.3	3688.3
1 1/2	38.10	-	-	-	-	1940	2200	2630.6	2983.2	3160	3560	4285.0	4827.4

METRIC BOLT TORQUE SPECIFICATIONS

Size of screw	Grade No.	Pitch mm	Coarse thread				Pitch mm	Fine Thread			
			Pounds-Foot		Newtons-Meter			Pounds-Foot		Newtons-Meter	
			MIN.	MAX.	MIN.	MAX.		MIN.	MAX.	MIN.	MAX.
M6	4T 	1.0	3.6	5.8	4.9	7.9	-	-	-	-	
	7T 		5.8	9.4	7.9	12.7	-	-	-	-	
	8T 		7.2	10	9.8	13.6	-	-	-	-	
M8	4T 	1.25	7.2	14	9.8	19.0	12	17	16.3	23.0	
	7T 		17	22	23	29.8	19	27	25.7	36.6	
	8T 		20	26	27.1	35.2	22	31	29.8	42	
M10	4T 	1.5	20	25	27.1	33.9	20	29	27.1	39.3	
	7T 		34	40	46.1	54.2	35	47	47.4	63.7	
	8T 		38	46	51.5	62.3	40	52	54.2	70.5	
M12	4T 	1.75	28	34	37.9	46.1	31	41	42	55.6	
	7T 		51	59	69.1	79.9	56	68	75.9	92.1	
	8T 		57	66	77.2	89.4	62	75	84	101.6	
M14	4T 	2.0	49	56	66.4	75.9	52	64	70.5	86.7	
	7T 		81	93	109.8	126	90	106	122	143.6	
	8T 		96	109	130.1	147.7	107	124	145	168	
M16	4T 	2.0	67	77	90.8	104.3	69	83	93.5	112.5	
	7T 		116	130	157.2	176.2	120	138	162.6	187	
	8T 		129	145	174.8	196.5	140	158	189.7	214.1	
M18	4T 	2.0	88	100	119.2	136	100	117	136	158.5	
	7T 		150	168	203.3	227.6	177	199	239.8	269.6	
	8T 		175	194	237.1	262.9	202	231	273.7	313	
M20	4T 	2.5	108	130	146.3	176.2	132	150	178.9	203.3	
	7T 		186	205	252	277.8	206	242	279.1	327.9	
	8T 		213	249	288.6	337.4	246	289	333.3	391.6	

Manufactured by:



2835, Chemin de l'Aéroport
Thetford Mines, Québec, Canada, G6G 5R7
Tel.: (418) 338-4499 - Fax: (418) 338-6090
e-mail : radtech@radinter.com
Internet : www.radinter.com

Printed in Canada