

BLIZZARD

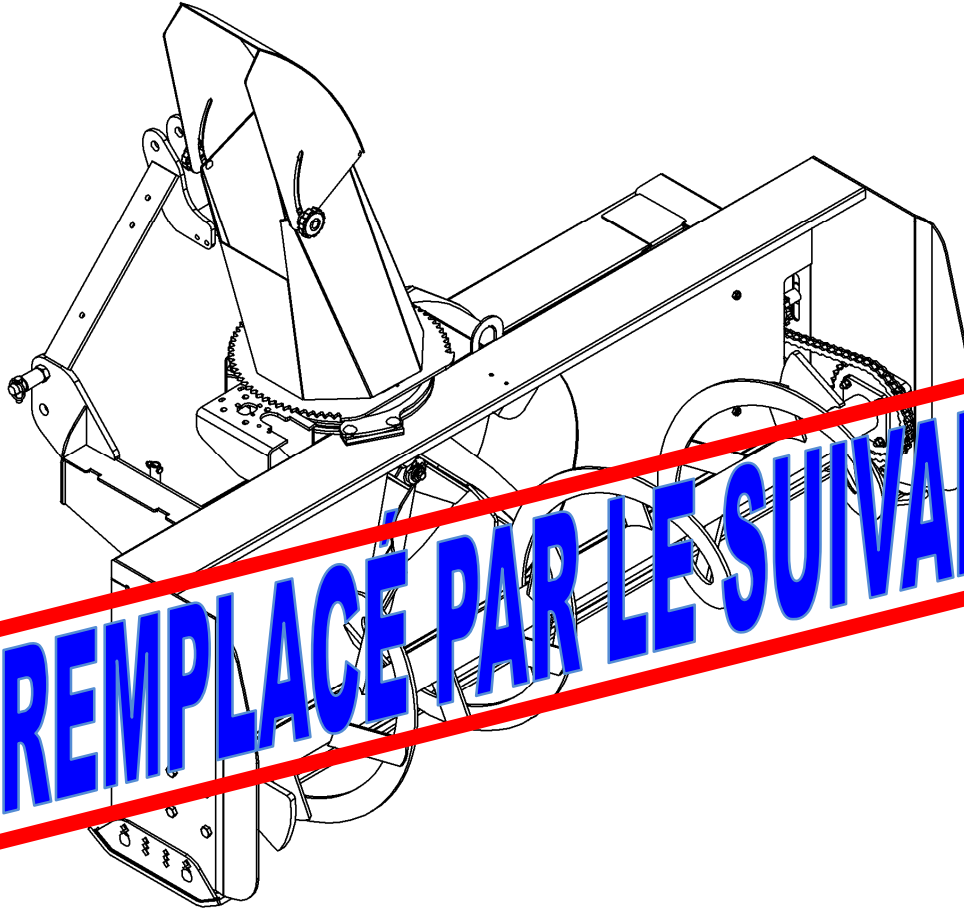

OPERATOR'S AND PARTS MANUAL

**SNOWBLOWER
BLIZZARD B74C MODEL**

SERIAL NO. SMT109192 AND UP

**OM 0410SB-A
02/12**



TABLE OF CONTENT

SPECIFICATIONS.....	3
INTRODUCTION – TO THE PURCHASER.....	4
SAFETY PRECAUTIONS	5-11
Before Operation	5
Notice.....	6
The Snowblower.....	6-8
Before Operation.....	6
Snowblower Operation	7
Stay Clear of Rotating Drivelines	8
The Tractor	9-10
General Information	9
Operating the Tractor.....	9
During Operation.....	9
Roll-Over Protective Structure (ROPS).....	10
Transport.....	10
Maintenance	11
Storage	11
SAFETY DECALS	12
ASSEMBLY.....	13-31
Tractor Preparation	13
Snowblower Assembly	13-31
Installation of Chute.....	13
Installation of Snowblower with Three Point Hitch	14
Installation of Snowblower with Quick Hitch.....	15
Installation of Manual Rotation Kit BER0077	16-17
Installation of Hydraulic Rotation Kit BER0077	18-20
Installation of Hydraulic Deflector Kit BER0079.....	21-22
Installation of Electric Deflector Kit 8151	23-25
How to Determine Driveline Angles	26
Angles at Each End of Driveline.....	27
Determining Driveline Length.....	27-28
Driveline Installation.....	29
Removing Snowblower from Tractor	30-31

TABLE OF CONTENT

OPERATION	32-33
General Preparation	32
Operating Controls	32
Work and Travel Speed	32
Raising and Lowering the Snowblower.....	32
Adjustments	32
Chain Tension Adjustment	32
Skid Shoe Adjustment	32
Manual Deflector Adjustment	32
Snow Removal Methods	33
MAINTENANCE.....	34-38
Maintenance	34
Shearbolts	34
Drive shaft.....	34
Driveline.....	34
Lubrication.....	35
Driveline – Troubleshooting	36-38
PARTS	39-48
Introduction	39
Manual Holder.....	39
Snowblower - B74C	40-42
Gearbox 663485	43
Driveline 4700159	44
BER0077 - Manual Rotation.....	45
BER0078 - Hydraulic Rotation	46
BER0079 - Hydraulic Deflector	47
8151- Electric Deflector	48
TORQUE SPECIFICATION TABLE	49

SPECIFICATIONS

Features and Specifications	B74C
Working Width	74"
Transport Width	74"
Working Height	26"
Length	47 3/4"
Single/Dual Auger	Single
Auger Diameter	15"
Auger Flighting Thickness	5/16"
Impeller Diameter	24"
Impeller Width	9"
Impeller Shaft Diameter	1 3/8"
Number of Impeller blades	4
Roller Chain	60
Drive sprocket (# of teeth)	12
Driven sprocket (# of teeth)	32
Chain idler	Manual adjustment
Gearbox Manufacturer	Comer
Gearbox Description	Model T-281A
Tractor RPM	540
Impeller RPM	540
Auger RPM	200
PTO Manufacturer	Comer
PTO Description	40
Skid Shoe	Adjustable
Skid Shoe Material	High carbon steel
End Plate Thickness	3/16"
Back Plate Thickness	11ga
Impeller Housing Thickness	11ga
Impeller Blade Thickness	1/4"
Side Panel Bottom Thickness	3/16"
Cutting Edge	Welded
Cutting Edge Dimension	3/8" x 2"
Chute Base	Standard
Parking Stand	Standard
Hitch Category	Cat. 1 & 2
Quick Hitch Compatibility	ASABE Compatible Cat. 1 only
HP Requirements - min-max (hp)	20-50
Operating Weight (lbs)-hyd. rot. & defl.	715
Shipping Weight (lbs)	628
Approx. Set-up Time (min.) *	35
Chute Deflector Adjustment (standard)	Manual
Chute Deflector Adjustment (option)	Hydraulic: cylinder (2"x5"), brackets, support, hoses & connectors included. Electric: actuator 5" - 75 lb brackets, hardware, switch & wires included
Chute Rotation	Manual: worm gear w/ crank. Hydraulic: 50cc hyd.motor, flow restrictor, hoses & connectors included.
Chute	Two-part

* With manual rotation

INTRODUCTION

To THE PURCHASER

All BER-VAC and BLIZZARD products are designed to give safe, dependable service if they are operated and maintained according to instructions. **Read and understand this manual before operation.**

This manual has been prepared to assist the owner and operators in the safe operation and suitable maintenance of the implements. The information was applicable to products at the time of manufacture and does not include modifications made afterwards.

Read and understand this operator's manual before attempting to put an implement into service. Familiarize yourself with the operating instructions and all the safety recommendations contained in this manual and those labeled on the implements and on the tractor. Follow the safety recommendations and make sure that those with whom you work follow them.

Illustrations

The illustrations may not necessarily reproduce the full detail and the exact shape of the parts or depict the actual models, but are intended for reference only

Direction Reference

Right Hand and Left Hand are determined by those seen by the conductor standing behind the equipment.

The Dealer is responsible for warranty registration of the unit you have purchased. To assist your dealer in handling your needs, please record hereafter the model number and serial number of your implement and tractor. It is also advisable to supply them to your insurance company. It will be helpful in the event that an implement or tractor is lost or stolen.

MODEL :

SERIAL NUMBER :

DATE OF PURCHASE :

SAFETY PRECAUTIONS



SAFETY FIRST

This symbol, the industry's "Safety Alert Symbol", is used throughout this manual and on labels on the machine itself to warn of the possibility of personal injury. Read these instructions carefully. It is essential that you read the instructions and safety regulations before you attempt to assemble or use this unit.



DANGER : Indicates an imminently hazardous situation which, if not avoided, will result in death or serious injury.



WARNING : Indicates a potentially hazardous situation which, if not avoided, could result in death or serious injury.



CAUTION : Indicates a potentially hazardous situation which, if not avoided, may result in minor or moderate injury.

IMPORTANT : Indicates that equipment or property damage could result if instructions are not followed.

NOTE : Gives helpful information.

All products are designed to give safe, dependable service if they are operated and maintained according to instructions. **Read and understand this manual before operation.** It is the owner's responsibility to be certain anyone operating this product reads this manual, and all other applicable manuals, to become familiar with this equipment and all safety precautions. Failure to do so could result in serious personal injury or equipment damage. If you have any questions, consult your dealer.

BEFORE OPERATION

Children and Bystanders

Tragic accidents can occur if the operator is not alert to the presence of children. Children are generally attracted to machines and the work being done. Never assume children will remain where you last saw them.

1. Keep children out of the operating area and under the watchful eye of another responsible adult.
2. Be alert and turn machine off if children enter the work area.
3. Before and when backing, look behind and look for small children.
4. Never carry children while operating the machine. They may fall off and be seriously injured or interfere with safe operation of the machine.
5. Never allow children to play on the machine or attachment even when turned off.
6. Never allow children to operate the machine even under adult supervision.
7. Use extra care when approaching blind corners, shrubs, trees, or other obstructions that might hide children from sight.

SAFETY PRECAUTIONS - continued

NOTICE

A safe operator is the best insurance against accidents. All operators, no matter how experienced they may be, should read this Operator's Manual and all other related manuals before attempting to operate an implement. Please read the following section and pay particular attention to all safety recommendations contained in this manual and those labeled on the implements and on the tractor.

THE SNOWBLOWER

Before Operation

1. Read and understand this operator's manual and tractor operator's manual. Know how to operate all controls and how to stop the unit and disengage the controls quickly.
2. Never wear loose, torn, or bulky clothing around the tractor and implement. It may catch on moving parts or controls, leading to the risk of accident.
3. Before the snow season, thoroughly inspect the area where the equipment is to be used and remove all doormats, sleds, boards and other foreign objects.
4. Disengage clutch and shift into neutral before starting the engine.
5. Do not operate equipment in wintertime without wearing adequate winter garments.
6. Never attempt to make any adjustments while engine is running. Read this manual carefully to acquaint yourself with the equipment as well as the tractor operator's manual. Working with unfamiliar equipment can lead to accidents. Be thoroughly familiar with the controls and proper use of the equipment. Know how to stop the unit and disengage the controls quickly.
7. Keep all shields in place and properly tighten all mounting hardware.
8. Periodically, inspect all moving parts for wear and replace with authorized service parts if an excessive amount of wear is present.
9. Replace all missing, illegible, or damaged safety and warning decals. See list of decals in the operator's manual.
10. Do not modify or alter this equipment or any of its components, or any equipment function without first consulting your dealer.
11. Keep safety decals clean of dirt and grime.
12. Make sure the tractor is counterweighted as recommended by your dealer. Weights provide the necessary balance to improve stability, traction and steering.

SAFETY PRECAUTIONS- continued

Snowblower Operation

1. Before leaving the tractor/snowblower unattended, take all possible precautions. Park the tractor/snowblower on level ground, place the transmission in neutral, set the parking brake, disengage the PTO, lower the snowblower to the ground, place all levers including auxiliary control levers in neutral, shut off the engine and remove the ignition key.
2. Before starting the tractor/ snowblower, remove the ice that might have accumulated on the auger/fan, inspect and clean every rotating part.
3. Prior to operation, clear work area of all objects that can be picked up and thrown. Mark all curbs, pipes, etc. that cannot be moved.
4. Be sure the PTO switch/lever is in OFF/disengaged position before starting engine.
5. Exercise extreme caution when operating on or crossing a gravel drive, walks, or roads. Stay alert for hidden hazards or traffic.
6. Do not carry passengers.
7. Keep clear of all rotating parts. Do not put hands or feet under, or into snowblower with engine running. Be especially observant of the snowblower areas of discharge, intake or all other mechanical motions.
8. For your safety, do not work under any hydraulically supported machine elements that may creep down, suddenly drop or be accidentally lowered.
9. Park the tractor/snowblower on level ground, place the transmission in neutral, set the parking brake, disengage the PTO, lower the snowblower to the ground, place all control levers in neutral, shut off the engine, remove the ignition key and allow the rotating parts to stop BEFORE unclogging the housing or the chute and making any repairs, adjustments or inspections. Use only a 36" long stick of wood to unclog the snowblower.
10. If the snowblower starts to vibrate abnormally, disengage the PTO, stop the engine immediately and check for cause. Excessive vibration is generally a sign of trouble.
11. Do not run the engine indoors except when starting engine and transporting attachment in or out of building. Carbon monoxide gas is colorless, odorless and deadly.
12. Do not attempt to operate on steep slopes. If operating on slopes is necessary, exercise extreme caution when changing direction.
13. Never operate snowblower without guards, and other safety protective devices in place. All tractor and snowblower shields and covers must be correctly installed at all times. When necessary to remove these, they must be reinstalled immediately.
14. Never operate snowblower near glass enclosures, automobiles, window wells, embankments, etc., without proper adjustment of snow discharge angle.
15. Never operate machine at high transport speeds on a slippery surface.
16. Use extra caution when backing up.
17. Disengage power to auger/fan when transporting or when not in use.
18. Never operate the snowblower without good visibility and lighting.
19. Prolonged exposure to loud noise can cause impairment or loss of hearing. Wear a suitable hearing protective device such as earmuffs or earplugs to protect against objectionable or uncomfortable noises.
20. Never allow anyone near the work area.
21. Never allow anyone to operate the snowblower until they have read the manual completely and are thoroughly familiar with basic tractor and snowblower operation.
22. Make sure the tractor is counterweighted as recommended by your dealer. Weights provide the necessary balance to improve stability, traction and steering.
23. Always make sure all snowblower components are properly installed and securely fastened BEFORE operation.
24. Adjust housing height to clear gravel or crushed rocks surface.
25. Keep away from chute discharge. This chute has the capacity to throw debris at far distances.
26. Never direct chute discharge towards people or animals. A thrown debris can cause serious injury.

SAFETY PRECAUTIONS- continued

Stay Clear of Rotating Drivelines

1. Entanglement in rotating driveline can cause serious injury or death.
2. Keep tractor master shield and driveline shields in place at all times. Make sure rotating shields turn freely.
3. Wear close fitting clothing. Stop the engine and be sure that PTO driveline is stopped before making adjustments, connections, or cleaning out PTO driven equipment.
4. Do not install any adapter device between the tractor and the primary implement PTO drive shaft that will allow a 1000 rpm tractor shaft to power a 540 rpm implement at speeds higher than 540 rpm.
5. Do not install any adapter device that results in a portion of the rotating implement shaft, tractor shaft, or the adapter to be unguarded. The tractor master shield shall overlap the end of the splined shaft and the added adaptor device as outlined in the table.



PTO Type	Diameter	Splines	$n \pm 5 \text{ mm (0.20 in.)}$
1	35 mm (1.378 in.)	6	85 mm (3.35 in.)
2	35 mm (1.378 in.)	21	85 mm (3.35 in.)
3	45 mm (1.772 in.)	20	100 mm (4.00 in.)

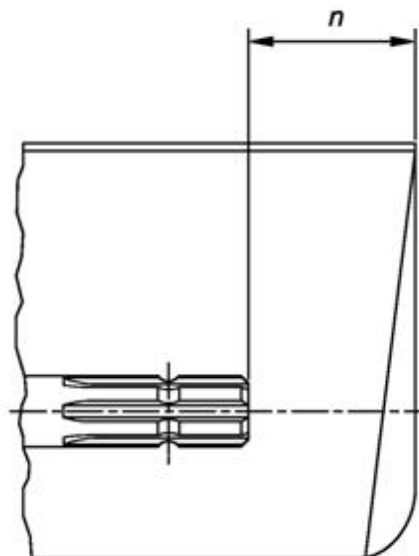

SAFETY PRECAUTIONS- continued

THE TRACTOR

General Information

1. Read the operator's manual carefully before using tractor. Lack of operating knowledge can lead to accidents.
2. Do not allow anyone but the operator to ride on the tractor. There is no safe place for extra riders

Operating the Tractor

1. Never run the tractor engine in a closed building without adequate ventilation, as the exhaust fumes are very dangerous.
2. Never allow an open flame near the fuel tank or battery.
3. Make sure the shield is installed when using a PTO-driven equipment and always replace the shield if damaged.
4. Always bring the tractor to a complete stop, shut off the engine, lower the implement to the ground and remove the ignition key before leaving the tractor.
5. Never park the tractor on a steep slope.
6. Do not attempt to operate on steep slopes.
7. Use of tire chains for better traction and stability is recommended.
8. Always drive the tractor at speeds compatible with safety, especially when operating over rough ground, crossing ditches, or when turning.
9. Handle fuel with care, as it is highly flammable.
10. Use approved fuel container.
11. Never add fuel to a running engine or a hot engine.
12. Fill fuel tank outdoors with extreme care. Never fill fuel tank indoors. Replace fuel cap securely and wipe up spilled fuel.
13. Never allow anyone to operate the snowblower until they are thoroughly familiar with basic tractor and snowblower operation.

14. A minimum 20% of tractor and equipment weight must be on the tractor front wheels when attachments are in transport position. Without this weight, tractor could tip over, causing personal injury or death. The weight may be attained with a loader, front wheel weights, ballast in tires or front tractor weights. Weigh the tractor and equipment. Do not estimate.

15. Always make sure all snowblower components are properly installed and securely fastened **BEFORE** operation.

During Operation

1. Do not allow anyone to ride on the tractor/snowblower at any time. There is no safe place for passengers on this equipment. The operator **MUST** sit in the tractor seat.
2. Eye and hearing protection is recommended when operating the snowblower.
3. Operate only during daylight hours, or when the area is well lit with bright artificial light.
4. Disengage the PTO (turn to "OFF"), place the transmission in neutral, set the parking brake, shut off the engine and remove the key, and make sure rotating components have stopped **BEFORE** leaving the operator's seat.
5. Inspect the snowblower after striking any foreign object to assure that all snowblower parts are safe and secure and not damaged.

SAFETY PRECAUTIONS- continued

Roll-Over Protective Structure (ROPS)

1. DO NOT weld, drill or alter the ROPS. Damaged ROPS must not be straightened or used. If damage does occur, consult your dealer.
2. If the ROPS is lowered or removed from the tractor for any reason, it must be erected and/or refitted immediately. Original bolts or equivalent replacements must be used and tightened to the correct torque.
3. Your dealer does not recommend usage of tractor with ROPS removed.
4. If a fold-down ROPS is used, the ROPS can be folded down for storage, but it must be pinned in the upright position prior to operation.
5. Seat belt usage: With ROPS installed on the tractor it is imperative that the seat belt be installed, used and correctly adjusted, at all times. DO NOT use a seat belt if operating without ROPS.

Additional Safety Equipment

Keep a fire extinguisher and a first aid kit within reach.

TRANSPORT

1. If the tractor/snowblower is to be driven on public roads, it must be equipped with an SMV (Slow Moving Vehicle) sign. Check local traffic codes that may apply to unit usage on public roads and highways in your area.
2. Be alert for all other traffic when driving the tractor/snowblower on public roads or highways.
3. Always disengage the snowblower before transport.

SAFETY PRECAUTIONS- continued

MAINTENANCE

ALWAYS USE GENUINE PARTS WHEN REPLACEMENT PARTS ARE REQUIRED

1. Keep the tractor and snowblower properly maintained.
2. Park the tractor/snowblower on level ground, place the transmission in neutral, set the parking brake, disengage the PTO, lower the snowblower to the ground, place all control levers in neutral, shut off the engine and remove the ignition key and allow the rotating parts to stop BEFORE making any snowblower adjustments.
3. To avoid injury, do not adjust, unblock the driving system, or service the snowblower with the tractor engine running. Make sure rotating components have completely stopped BEFORE leaving the operator's seat.
4. Keep the tractor/snowblower clean. Snow, dirt or ice build-up can lead to malfunction or personal injury from thawing and refreezing in garage.
5. Always wear eye protection when cleaning or servicing the snowblower.
6. DO NOT service the tractor while the engine is running or hot, or if the unit is in motion. Always lower snowblower to the ground. If necessary to service snowblower in raised position, securely support with stands or suitable blocking before working underneath. Do not rely on hydraulically supported devices for your safety. They can settle suddenly, leak down, or be accidentally lowered.
7. Do not attempt to service machine, clear obstructions or unclog the snowblower with the engine running. Always shut off engine and allow all motion to cease.
8. The manufacturer will not claim responsibility for fitment of unapproved parts and/or accessories and any damages as a result of their use.
9. Make sure all shields and guards are securely in place following all service, cleaning, or repair work.
10. Do not modify or alter this snowblower or any of its components or operating functions. If you have questions concerning modifications, consult with your dealer.
11. Do not operate a snowblower that is defective or has missing parts. Make sure that all recommended maintenance procedures are completed before operating the snowblower.
12. Check all controls regularly and adjust where necessary. Make sure that the brakes are evenly adjusted.
13. Periodically check all nuts and bolts for tightness, especially wheel hub and rim nuts.
14. To avoid serious personal injury: Escaping hydraulic/diesel fluid under pressure can penetrate the skin causing serious injury. Do not use your hands to check for leaks. Use a piece of cardboard or paper to search for leaks. If you are injured by escaping high pressure fluid, see a medical doctor at once.
15. Stop engine and relieve pressure before connecting or disconnecting hydraulic hoses. Tighten all connections before starting engine or pressurizing hoses.

STORAGE

1. Before storing the snowblower, certain precautions should be taken to protect it from deterioration.
2. Clean the snowblower thoroughly.
3. Make all the necessary repairs.
4. Replace all Safety Signs that are damaged, lost, or otherwise become illegible. If a part to be replaced has a sign on it, obtain a new safety sign from your dealer and install it in the same place as on the removed part.
5. Repaint all parts from which paint has worn or peeled.
6. Lubricate the snowblower as instructed under "Lubrication" section.
7. When the snowblower is dry, oil all moving parts. Apply oil liberally to all surfaces to protect against rust.
8. Attach driveline shield safety chain around driveline by passing it over the upper hitch.
9. Store in a dry place.

SAFETY DECALS

Replace immediately if damaged.

▲ DANGER



Avoid Injury From Rotating Auger:

- Keep hands, feet and clothing away.
- Shut off engine before servicing.

Pour Éviter Des Blessures Graves:

- Garder les mains, les pieds et les vêtements éloignés des vis sans fin.
- Arrêter le moteur avant de faire l'entretien.

646



662699

▲ DANGER



Avoid Injury from rotating gears:

- Keep hands and clothing away.
- Stop engine and remove ignition key before coming near rotating gears.
- Do not attempt to install or remove rotating gears without reading operator's manual.

Évitez les blessures par les engrenages :

- Garder mains et vêtements éloignés.
- Arrêter le moteur et enlever la clé de contact avant de vous approcher des engrenages.
- Ne tentez pas d'installer ou d'enlever les engrenages sans lire le manuel d'opérateur.

675

2500833

▲ DANGER



To Avoid Serious Injury:

- Keep hands out of discharge chute while engine is running.
- Shut off engine before unclogging discharge chute.

Pour Éviter Des Blessures Graves:

- Garder les mains éloignées de la chute lorsque le moteur est en marche.
- Arrêter le moteur avant de débloquer la chute.

646

2500782

▲ DANGER

2500608

664517 **B74**

BLIZZARD
664458

IMPORTANT

Before using:

- Oil level must be checked
- Fill with SAE 80W90, "AGMA 5 EP" extreme pressure oil or equivalent
- Read instructions manual

IMPORTANT

Avant usage:

- Vérifier le niveau d'huile
- Remplir avec de l'huile SAE 80W90, "AGMA 5EP" pression extrême ou équivalent
- Lire manuel d'instructions

21

655834

▲ DANGER



Avoid Injury From Rotating Auger:

- Keep hands, feet and clothing away.
- Shut off engine before servicing.

Pour Éviter Des Blessures Graves:

- Garder les mains, les pieds et les vêtements éloignés des vis sans fin.
- Arrêter le moteur avant de faire l'entretien.

646

2500783

▲ DANGER



Rotating Driveline Contact Can Cause Death. Keep People And Clothing Away. Do not operate without:

- All driveline, tractor and equipment shields in place.
- Driveline securely attached at both ends.
- Driveline shield turning freely on driveline.

Transmission Rotative À Cardan. Tout Contact Peut Causer La Mort. Tenir Les Vêtements Et Personnes À L'écart Ne pas opérer sans:

- Que tous les protecteurs du tracteur, de l'équipement et de l'arbre à cardan soient en place.
- L'arbre à cardan fixé solidement à chaque bout.
- Que les protecteurs tournent librement sur l'arbre à cardan.

646

2500792

▲ ATTENTION

Pour Éviter Des Blessures Sérieuses:

- Lire le Manuel de l'Opérateur avant de manoeuvrer, d'effectuer l'entretien ou de réparer l'équipement. Suivre toutes les consignes de sécurité. Les manuels sont disponibles chez votre concessionnaire.
- Ne jamais laisser des passagers monter sur l'équipement.
- Garder les spectateurs loin de l'équipement pendant les opérations.
- Toujours manoeuvrer l'équipement à partir du siège du tracteur.
- Maintenir les gardes en place en tout temps et en bonne condition.
- Abaisser l'équipement au sol, couper le contact, retirer la clé et appliquer le frein avant de quitter le tracteur.
- Ne jamais laisser un enfant ou une personne non formée manoeuvrer l'équipement.

646

2500786

▲ DANGER



ROTATING DRIVELINE CONTACT CAN CAUSE DEATH. KEEP AWAY!

NE PAS ACTIONNER SANS LES DROITES DE PROTECTION POUR PASSENGERS/ÉTOURNEURS

DO NOT OPERATE WITHOUT ALL DRIVELINE, TRACTOR AND EQUIPMENT SHIELDS IN PLACE AND ATTACHED AT BOTH ENDS. DRIVELINE SHIELDS THAT TURN FREELY ON DRIVELINE.

NE PAS ACTIONNER SANS LES DROITES DE PROTECTION POUR PASSENGERS/ÉTOURNEURS

NE PAS ACTIONNER SANS LES DROITES DE PROTECTION POUR PASSENGERS/ÉTOURNEURS

18h 8h 16h 16h

MADE IN ITALY

2500813

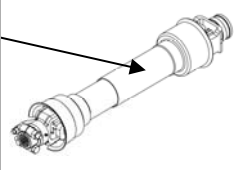

▲ CAUTION

To Avoid Serious Injury:

- Read operator's manual before operating, servicing or repairing equipment. Follow all safety rules and instructions. (manuals are available from your selling dealer.)
- Never allow riders.
- Keep bystanders away from equipment during operation.
- Operate from tractor seat only.
- Keep all shields in place and in good condition.
- Lower equipment to ground, stop engine, remove key and set brake before dismounting tractor.
- Never allow children or untrained persons to operate equipment.

646

5RD2500785

ASSEMBLY

TRACTOR PREPARATION

See Dealer for Tractor Preparation information.

SNOWBLOWER ASSEMBLY

The snowblower is assembled at the factory except for the parts in the hardware bag provided with the snowblower, the chute and the options if appropriate. Use the present manual and lay out all parts for assembly. Separate bolts and nuts into various sizes. After assembly, torque all the bolts according to the **Torque Specification Table** at the end of manual.

Installation of the Chute (Figure 1)

- Figure 1:** Place the rotation bushing (item 1) on the chute base of the snowblower.
- Figure 1:** Install the chute (item 2) over the rotation bushing and install the three 3/16" spacers (item 3) and the 3/8" spacers (item 4).
- Figure 1:** Insert the two three holes retaining plates (item 5) by placing the large section toward the support of the hydraulic motor. Secure with two 1/2"NC x 3/4" carriage bolts (item 7), upside down (front of the chute) and the four other bolts head up (rear of the chute). Secure with six 1/2" lockwashers (item 8) and four 1/2"NC hex nuts (item 9).
- Tighten all bolts according to the **Torque Specification Table** at the end of the manual.

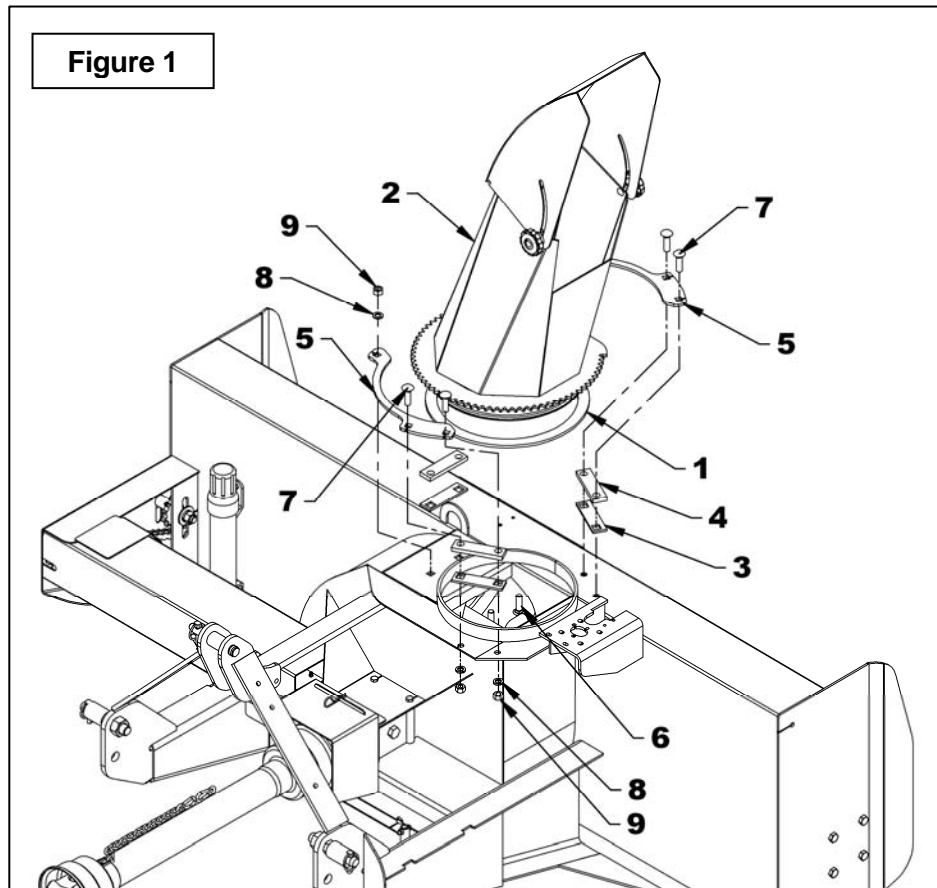

ASSEMBLY

Installation of Snowblower with Three Point Hitch

(Figure 2)

1. Install the two cat.1 pins (item 1) on the right and left snowblower hitches in the lower holes as shown on figure.
2. **Category 1:** Attach tractor lower links (item 2) to the snowblower hitch pins (item 1) and secure with the linchpins (item 3).
3. **Category 2:** Insert the 1 1/8" OD x 1 3/4" lg bushings (item 9) on each pin (item 1). Attach tractor lower links (item 2) to the snowblower hitch pins (item 1) and secure with the linchpins (item 3).
4. **Category 1:** Attach the tractor upper link (item 4) between the upper attaching plates (item 6) using the tractor pin and linchpin (item 5 – not included).
5. **Category 2:** Insert a 1" OD x 2" lg bushing (4600056) (item 10, not included) on a 3/4" dia. x 5 7/16" lg pin (4600051) (item 5- not included). Attach the tractor upper link (item 4) between the upper attaching plates (item 6) using the bushing, the pin and the tractor linchpin (item 5 & 10 – not included).
6. Adjust the snowblower using the tractor upper link so that the snowblower operates parallel to the ground.
7. Set the tractor anti-sway turnbuckles so the snowblower does not sway. Be sure there is no contact with the tires.
8. Install the eyebolt (item 7) in the upper hole of the left or right side of the three point hitch by screwing the eyebolt nut to the top and locking eyebolt in place with a 3/8" serrated flange nut (item 8).



CAUTION

Before connecting snowblower driveline to tractor drive shaft, make sure driveline is not too long in raised, lowered and middle position. If the driveline is too long it must be shortened, to avoid damaged to tractor. See pages 26 to 28 for instructions.

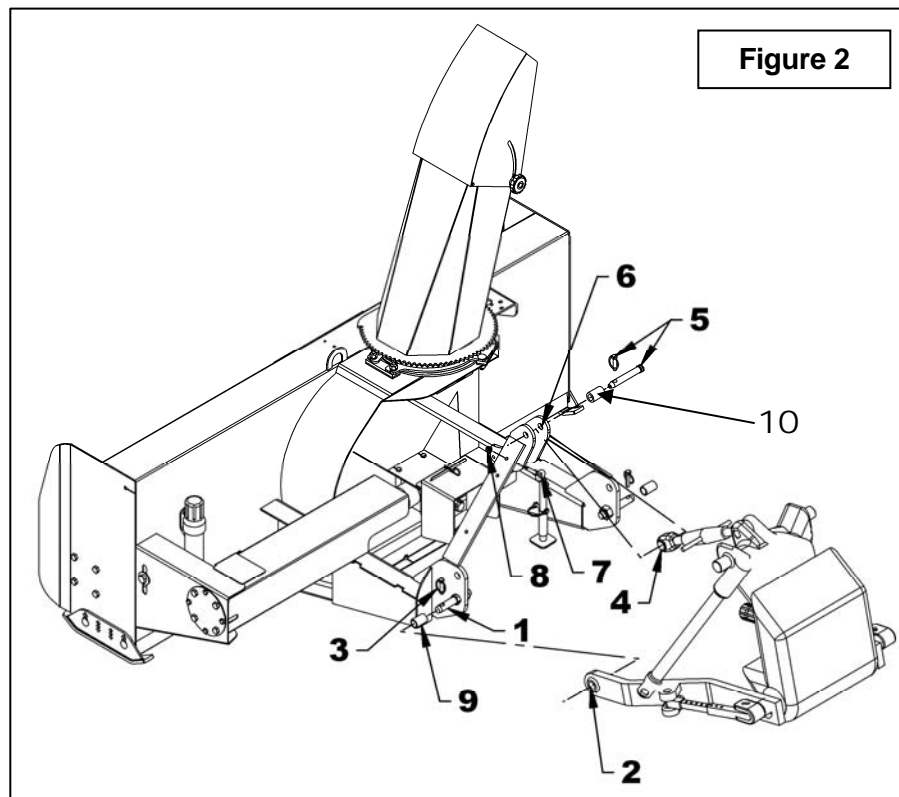

ASSEMBLY

Installation of Snowblower with Quick Hitch

(Figure 3)

CATEGORY 1 only

1. Install the two cat.1 pins (item 2) on the right and left snowblower hitches in the upper holes leaving 3 1/4" between the jam nut and the end of the pin as shown on figure.
2. Insert the two 2 1/8" lg bushings (item 3) on each pin and lock in place with the two 7/16" linchpins (item 4).
3. Insert the 1 7/8" lg bushing (item 5) between the upper attaching plates and lock in place with the tractor hitch pin and a 7/16" linchpin (items 6-7).
4. Install the eyebolt (item 8) in the upper hole of the left or right side of the three point hitch by screwing the eyebolt nut to the top and locking eyebolt in place with a 3/8" serrated flange nut (item 9).



CAUTION

Before connecting snowblower driveline to tractor drive shaft, make sure driveline is not too long in raised, lowered and middle position. If the driveline is too long it must be shortened, to avoid damaged to tractor. See pages pages 26 to 28 for instructions.

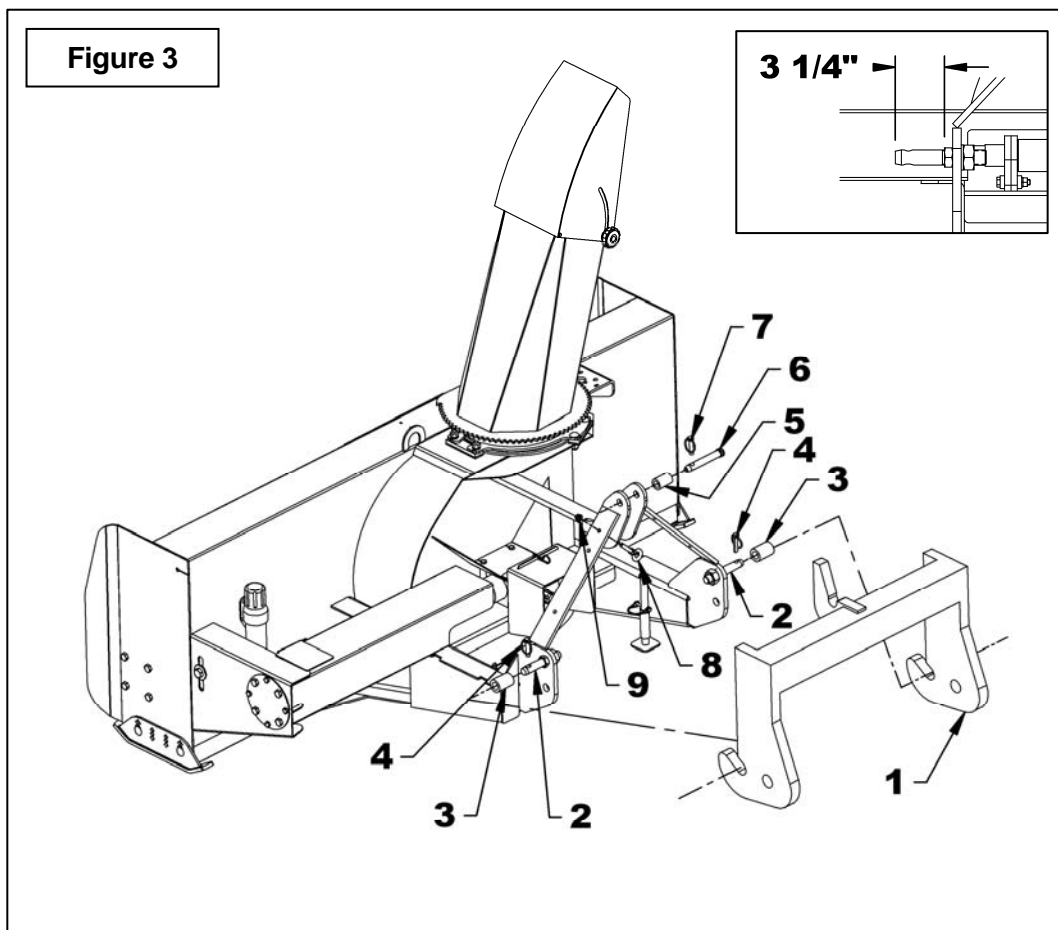

ASSEMBLY

Installation of Manual Rotation Kit BER0077

(Figures 4-5-6-7)

NOTE: The rotation handle can be installed on the right or left side of the three point hitch.

1. Install the chute according to the instructions contained in the snowblower Operator's Manual, with the four 1/16" thick spacers provided with the BER0077 kit.
2. **Figure 4:** Install the rotation tube support (item 1) on the chute base. Secure using a 1/4"NC x 3/4" bolt, a 1/4" lockwasher and a 1/4"NC nut (items 6-7-8). Do not tighten.
3. **Figure 4:** Insert a 1 5/16" plastic bushing (item 2) in the rotation tube support (item 1), then insert the rotation worm (item 3).
4. **Figure 4:** Insert the other 1 5/16" plastic bushing (item 5) in the rotation worm support (item 4), and then slide on the rotation worm. Secure with two 1/4"NC x 3/4" bolts and 1/4"NC nuts (items 9-10-11). Do not tighten.
5. **Figure 5:** Install the bracket (item 1) on the 3 point right or left hitch using two 3/8"NC x 1 1/4" bolts, 3/8" lockwashers and 3/8"NC nuts (items 2-3-4). Tighten securely.

6. **Figure 5:** Install handle support bracket (item 5) on the bracket (item 1) using a 3/4"NC x 1 1/2" bolt, 3/4"lockwasher and 3/4"NC nut (items 6-7-8). Do not tighten.
7. **Figure 5:** Install the plastic grommet (item 9) in the handle support (item 10).
8. **Figure 5:** Insert handle support (item 10) inside the handle support bracket (item 5). Fasten loosely with a 3/8"NC x 1/2" square head set screw (item 11).

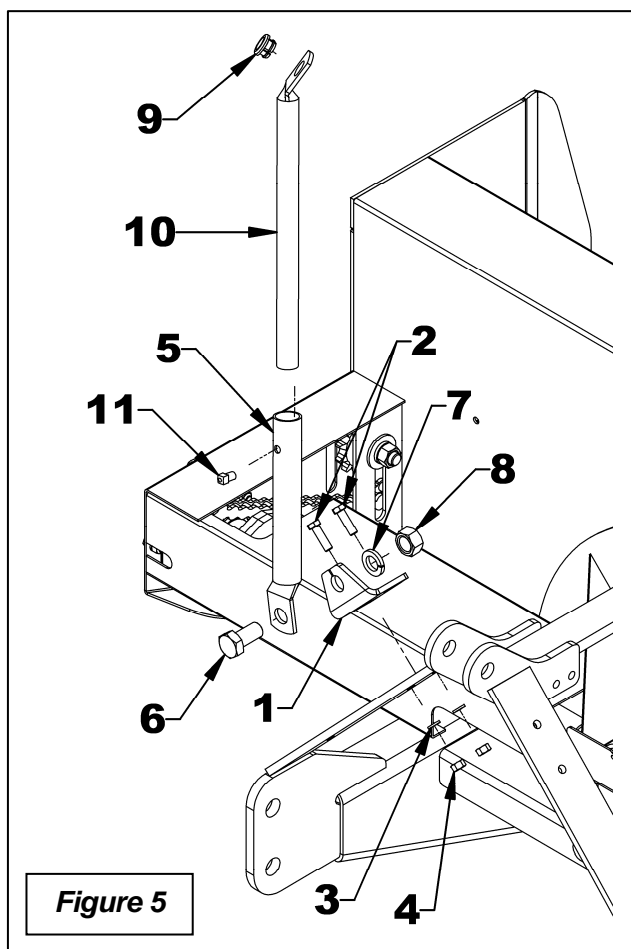
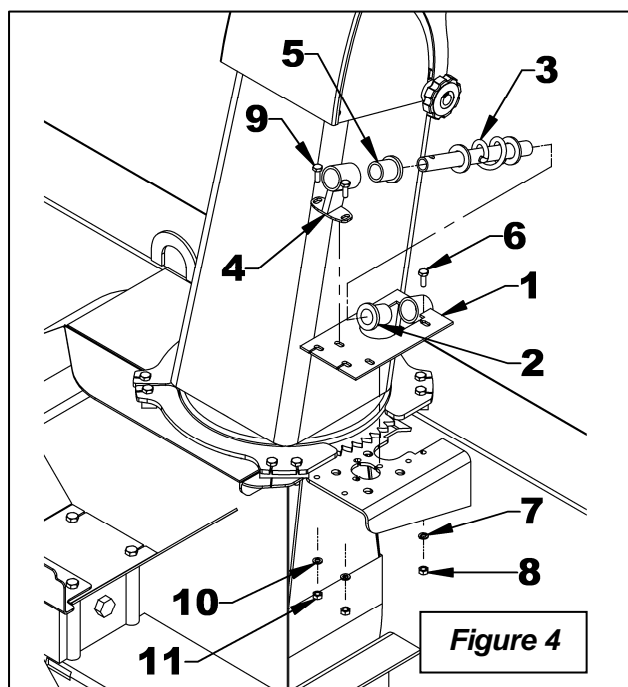

ASSEMBLY

9. **Figure 6:** Install plastic handle (item 5) over the rotation handle (item 6).
10. **Figure 6:** Insert assembled rotation tube (item 1) inside the rotation worm assembly (items 2). Align holes and insert a 10-24NC x 1" allen socket head capscrew (item 3) making sure the capscrew sinks into the worm. Secure with a nylon insert locknut (item 4). Adjust the height of the handle support according to your needs and shorten if necessary.
11. **Figure 6:** Insert the rotation handle (item 6) inside the grommet and inside the rotation tube (item 1). Select desired length, align nearest holes and secure with a 4mm x 80mm hairpin (item 8).
12. **Figure 7:** Adjust the rotation tube support (item 3) and the rotation worm support (item 1) by moving them toward the chute so the rotation worm is engaged between the gear teeth of the chute. Make sure the rotation worm and the bushings are well aligned. Tighten slightly the three 1/4"NC x 3/4" bolts and the three 1/4"NC nuts (item 2).
13. **Figure 7:** Rotate the chute completely to the right then to the left using the rotation handle (item 4).
 - If the chute is too hard to turn it's because the rotation worm is engaged too deep between the gear teeth, move the worm slightly away from the gear teeth and try again.
 - If the chute rotates with difficulty because the teeth do not engage or engage incorrectly, adjust the rotation handle support toward the chute and redo the steps.

14. **Figure 7:** Make sure the worm engages completely when it reaches the end of the chute gear. The rotation handle is well adjusted when the chute rotates easily without straining. Tighten firmly the three 1/4"NC x 3/4" bolts and the three 1/4"NC nuts (item 5).
15. **Figure 7:** After the snowblower is mounted to the tractor, you may adjust the rotation handle position and height to a comfortable and safe operating position. When the desired position is set for working position, make sure the rotation handle is not interfering with any parts of the tractor while on transport position (snowblower raised to maximum). Tighten firmly the 3/8"NC x 1/2" square head setscrew 3/8"NC x 1/2" (item 5) to the desired height. Then tighten firmly the 3/4"NC x 1 1/2" bolt (item 6) to the desired position.

16. Lubricate the rotation worm.

NOTE: To insure the manual rotation operates properly, the handle support (**fig.6**, item 7) must be positioned the closest possible to the top link mounting point of the three point hitch while making sure it does not come into contact with the operator's seat when the snowblower is fully raised.

⚠ CAUTION: To avoid personal injury, check the full lifting range of the snowblower, to ensure that the chute rotation handle is clear of the operator's area when the snowblower is in raised position.

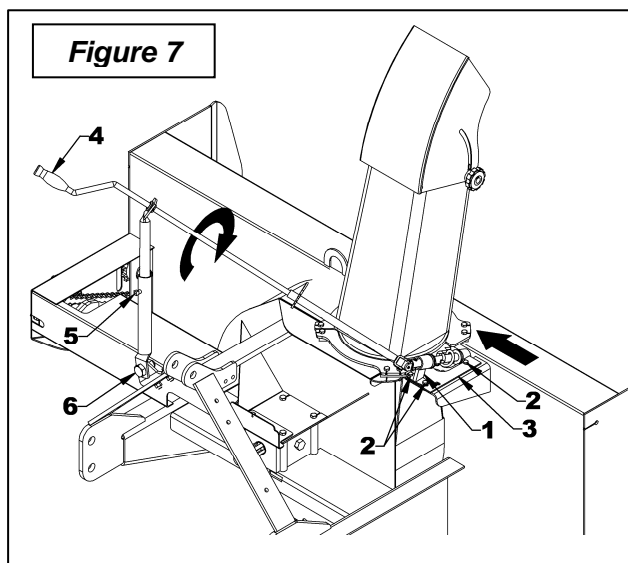
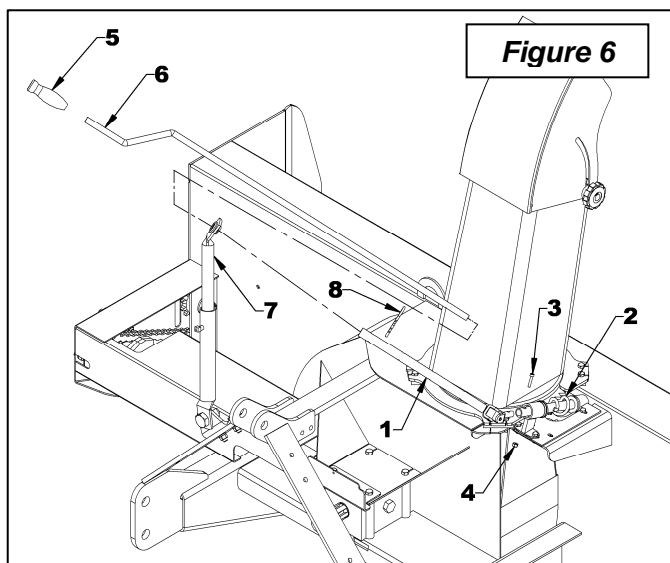

ASSEMBLY

Installation of Hydraulic Rotation Kit BER0078

(Figures 8 to 12)

1. Install the chute according to the instructions contained in the snowblower Operator's Manual.
2. **Figure 10:** Place the motor spacer (item 2) on the motor top (item 1) by aligning the holes. Install the motor (item 1) under the frame base of the snowblower and secure with four 3/8"NC x 1" bolts (item 3), four 3/8" lockwashers (item 4) and four 3/8" (7/16" hole) flat washers (item 5). Torque slightly.
3. **Figure 10:** Make sure the Woodruff key is on the motor shaft and insert the motor gear (item 6) on the shaft. Secure with a 1/4"NC x 1" bolt (item 7), a 1/4" lockwasher (item 8) and a 1/4" (5/16" hole) flat washer (item 9).
4. **Figure 11: NOT INCLUDED:** Using thread sealant, install a 1/4"NPT female x 1/2"NPT male reducer (item 2), a male quick coupler (item 3) and a dust cap (item 4) on each straight end of the hoses (item 1).

CAUTION

To avoid serious personal injury. Escaping hydraulic/ diesel fluid under pressure can penetrate the skin causing serious injury.

- Do not use your hands to check for leaks. Use a piece of cardboard or paper to search for leaks.

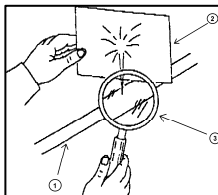
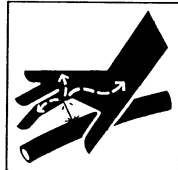

1. Hydraulic hose
2. Cardboard
3. Magnifying glass

- Stop engine and relieve pressure before connecting or disconnecting lines.
- Tighten all connections before starting engine or pressurizing lines.
- If any fluid is injected into the skin, obtain medical attention immediately or gangrene may result.

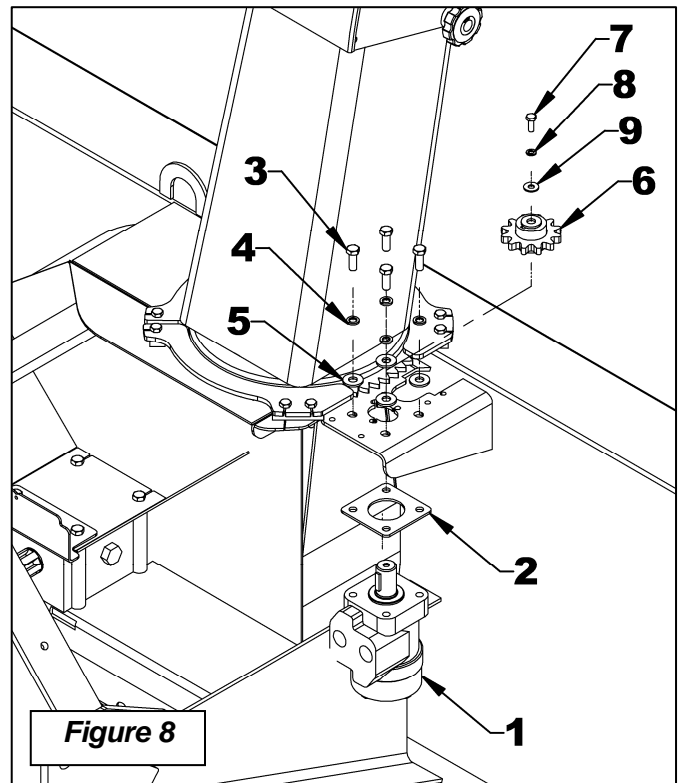

Figure 8

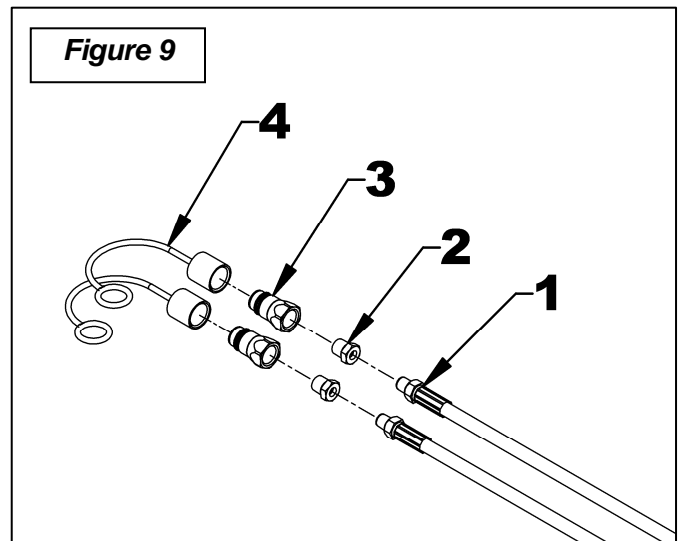

Figure 9

ASSEMBLY

5. **Figure 10:** Install a 0.052" flow restrictor (item 2) in each motor input (item 1).

6. **Figure 10:** **NOT INCLUDED:** Connect the two hoses (item 3) on the motor flow restrictors (item 2). Direct the hose elbows toward the snowblower upper arm.

7. **Figure 10:** **NOT INCLUDED:** Run hoses on the snowblower with suitable bend, staying away from sharp edges, nor compromise the snowblower maintenance. Attach to the right or left snowblower three point arm with a hose clamp (item 4), a 3/8"NC x 1 1/2" bolt (item 5) and a 3/8"NC nylon insert locknut (item 6).

8. **NOT INCLUDED:** Connect hoses to tractor and make sure to raise and lower the snowblower in extreme positions, and check if hoses are long enough to not interfere with any parts. Attach hoses with nylon tie wrap to appropriate places. Rotate the chute to the right and to the left.

9. **Figure 11:** **Motor adjustment:** Push the motor toward the chute as to well set the gear teeth (item 1) without leaving any play between teeth. Firmly tighten the four 3/8"NC x 1" bolts (item 2). If the rotation does not operate correctly, redo the adjustment.

10. **Figure 11:** Install the gear shield (item 3) and secure with two 1/4"NC x 3/4" bolts (item 4), two 1/4" lockwashers and two 1/4"NC nuts (items 5-6), as illustrated.

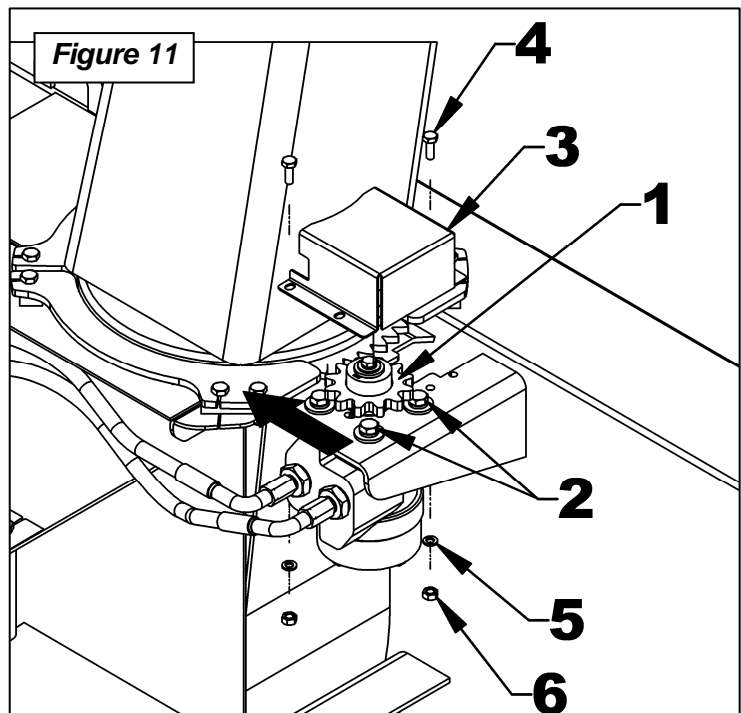
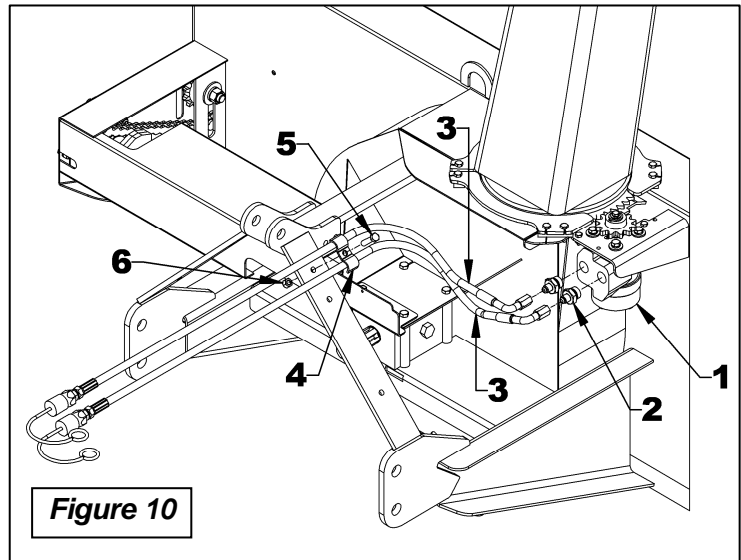

ASSEMBLY

Installation of Hydraulic Deflector Kit BER0079

(Figures 13 to 18)

1. Install the chute according to the instructions in the snowblower Operator Manual.
2. **Figure 13:** Remove the two manual adjustment knobs (item 1) and bolts (item 2) from each side of deflector and replace with two 5/16" NC x 3/4" carriage bolts (item 3), using original nylon washers (item 5-6) and two 5/16" NC nylon insert locknuts (item 4). Place one insert locknut outside the deflector and one (item 6) between the deflector and the chute base. Do not tighten completely to allow deflector movement by hand.
3. **Figures 14 & 15:** Place the deflector bracket (item 1) on center of chute deflector (item 2), flush with bottom edge of deflector (detail A). Using this bracket as a template, drill four 1/2" holes in deflector.
4. **Figure 15:** Bolt in place with four 5/16" x 3/4" allen flat socket head capscrews (item 3) and 5/16" serrated flange nuts (item 4), with the capscrews heads inside the chute. Tighten so that capscrews heads sink into deflector surface.
5. **Figure 15:** Retract hydraulic cylinder rod (item 5) completely and secure to deflector bracket (item 1) and deflector base bracket (item 6), using the two cylinder pins (item 7) and the two cotter pins (item 8). Direct the cylinder ports toward the snowblower center.
6. **Figure 15:** Open deflector to maximum so that actuator rod retracts completely. Place deflector base bracket (item 6) on the center rear of chute and using the bracket as a template, drill four 1/2" holes in chute.
7. **Figure 15:** Bolt deflector base bracket (item 6) to chute using four 5/16" x 3/4" allen flat socket capscrews (item 9) and 5/16" serrated flange nuts (item 10), with the capscrews heads inside the chute. Tighten so that capscrews heads sink into chute base surface.

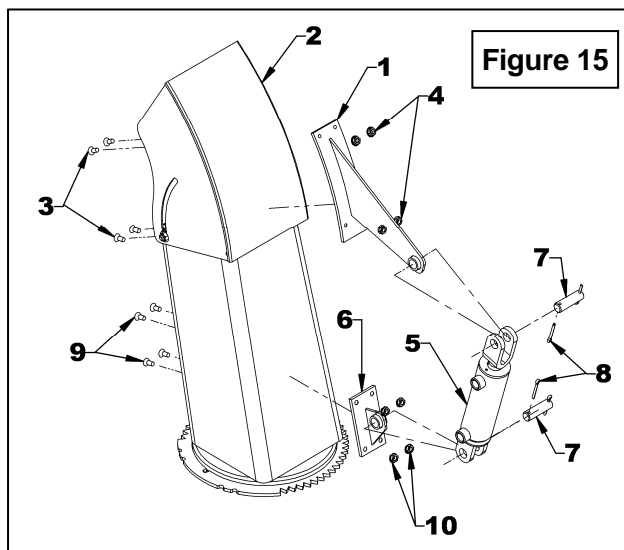
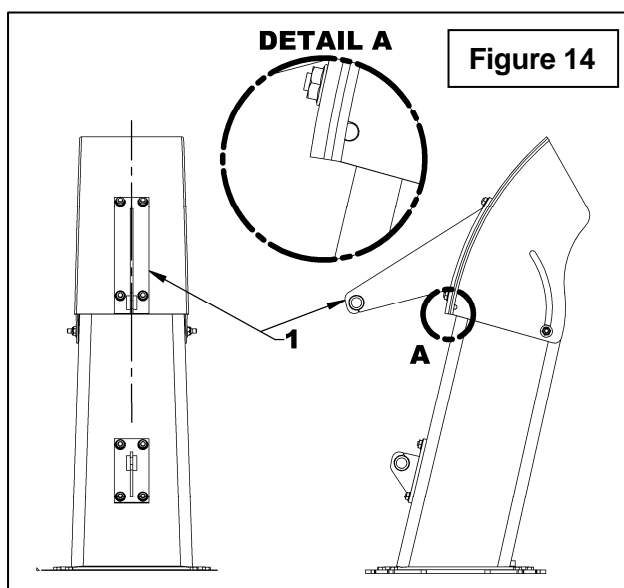
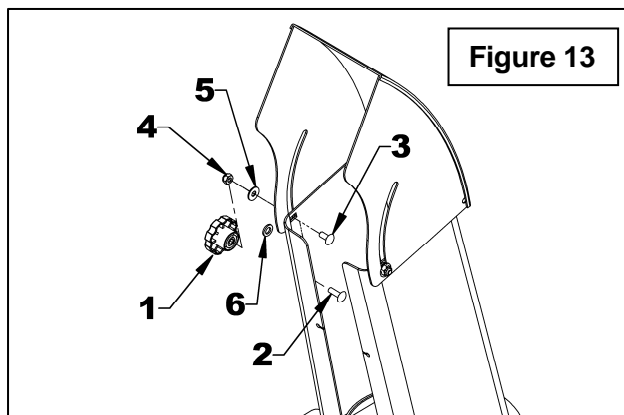

ASSEMBLY

8. **Figure 16:** Install the hose support (item 1) on the three point upper hitch bracket (item 2) right or left (right one is recommended) using two 3/8"NC x 1 1/2" bolts (item 3) and two 3/8"NC nylon insert locknuts (item 4).

9. **Figure 16:** With thread sealant, install a 90° 3/8" NPT male x 1/4" NPT swivel female elbow (item 5) in each cylinder port (item 6). Direct elbows upward by placing the lower one so that the hose does not interfere with the upper hose.

10. **Figure 17: NOT INCLUDED:** With thread sealant, install a 1/4" NPT female x 1/2" NPT male reducer (item 2), a male quick coupler (item 3) and a dust cap (item 4) on each hose straight end (item 1).

11. **Figure 18: NOT INCLUDED:** Connect the two hoses (item 1) to the cylinder elbows (item 2).

NOTE: The **figure 18** is a suggested presentation for hose routing. In that way, it prevents the hoses from getting clamped in the chute gear. However, other ways are also possible. In any way, make sure there is enough play in the hoses for the chute to rotate freely from left to right without forcing on hoses.

12. **Figure 18: NOT INCLUDED:** Run hoses on the snowblower with suitable bend, staying away from sharp edges, nor compromise the snowblower maintenance. Attach to the hose support (item 3) with a hose clamp (item 4), a 3/8"NC x 1 1/2" bolt (item 5) and a 3/8"NC nylon insert locknut (item 6).

13. **NOT INCLUDED:** Connect hoses to tractor and make sure to raise and lower the snowblower in extreme positions, and check if hoses are long enough to not interfere with any parts. Attach hoses with nylon tie wrap to appropriate places. Move the deflector from top to bottom to verify operation.

⚠ CAUTION

To avoid serious personal injury. Escaping hydraulic/ diesel fluid under pressure can penetrate the skin causing serious injury.

- Do not use your hands to check for leaks. Use a piece of cardboard or paper to search for leaks.

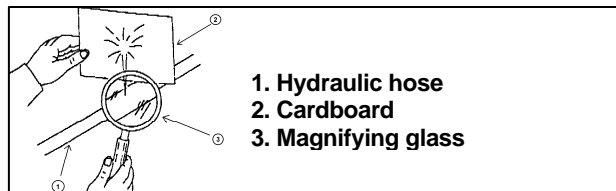
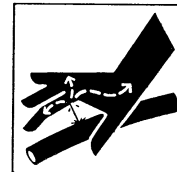

- Stop engine and relieve pressure before connecting or disconnecting lines.
- Tighten all connections before starting engine or pressurizing lines.
- If any fluid is injected into the skin, obtain medical attention immediately or gangrene may result.

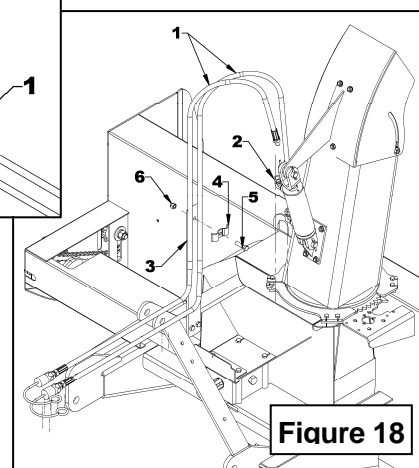
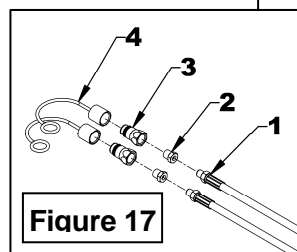
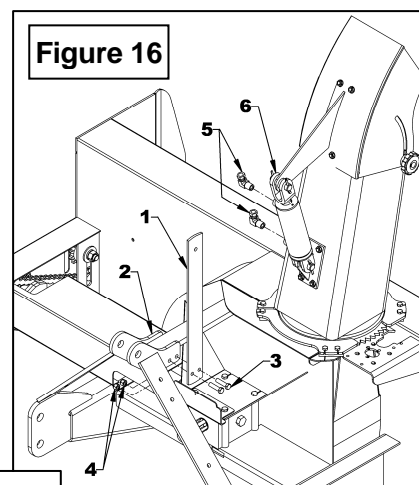

ASSEMBLY

Installation of Electric Deflector Kit 8151 (Figures 19 to 21 & Electrical Diagram)

PRE-ASSEMBLY

- Figure 19A:** Install the clevis with the 1 1/32" diam. hole (item 1) on the actuator base (item 2), and the one with the 1 5/32" diam. hole (item 3) on the other end and attach using two 1/2" NC x 2 1/2" bolts and two 1/2" NC nylon insert locknuts (items 4-5).
- Figure 19A:** Install a 3/16" x 1 3/4" spring pin (item 6) on each 1" pin (item 7).
- Figure 19 & diagram:** Connect the wires to the switch as follows:
 - 72" black ground wire (item 1) to terminal "C" (see diagram).
 - 72" red fuse wire (item 3) to terminal "B" (see diagram).
 - 360" red and black actuator wires (item 4) to terminal "A" and "D" (see diagram).

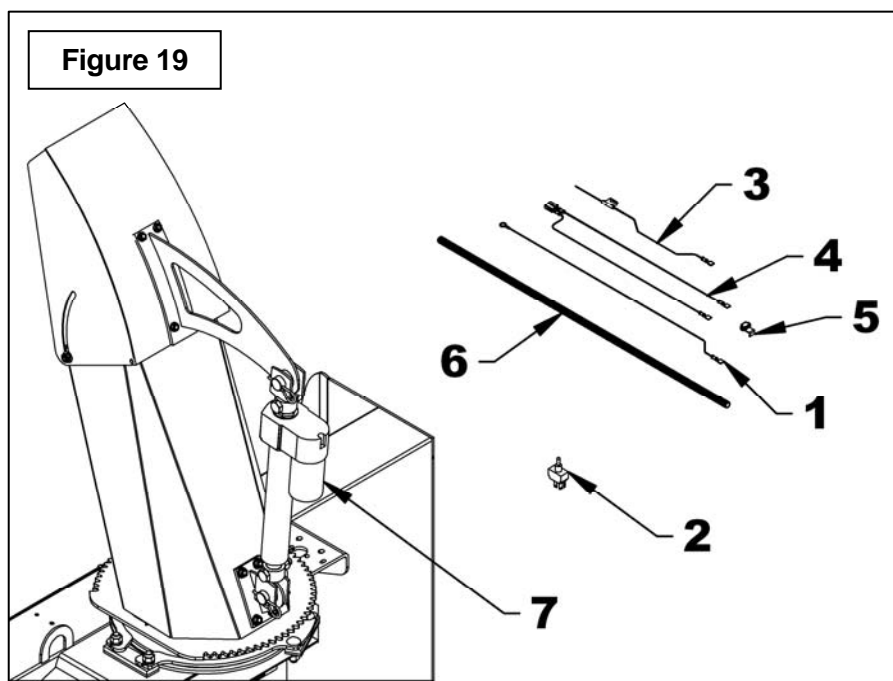
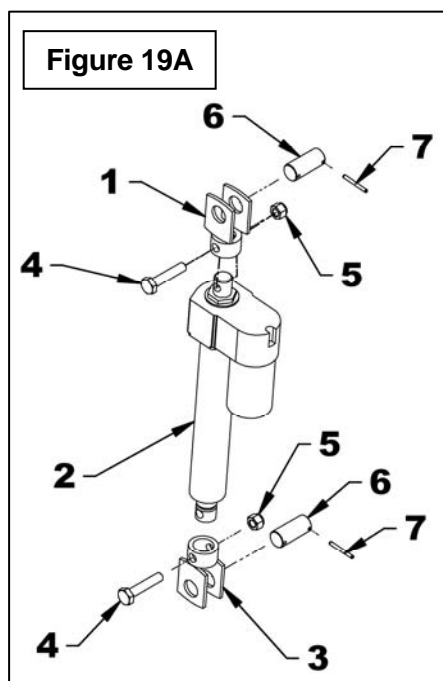
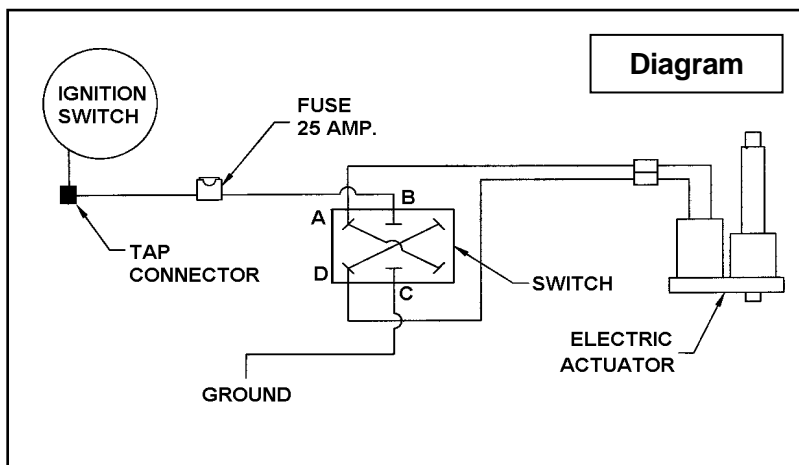

ASSEMBLY

ASSEMBLY

For Chute with knob adjustment:

- 1. Figure 20:** Remove the two manual adjustment knobs and the bolts on each deflector side (item 11) and replace with two 5/16" NC x 3/4" carriage bolts (item 1), the original nylon insert locknuts (item 2) and two 5/16"NC nylon insert locknut (item 3). Leave a 1/16" play.
- 2. Figure 20:** Place the deflector bracket (item 5) in the middle of the chute deflector, and align with the bottom edge of the deflector. Using the bracket as a template, drill four 1/2" holes in the deflector.
- 3. Figure 20:** Secure in place with four 5/16" NC x 3/4" allen flat head setscrews (item 4) and 5/16" serrated flange nuts (item 6), placing the setscrew head inside the chute. Tighten until the setscrew head sinks into the inside surface of the deflector.

- 4. Figure 20:** Retract completely the pre-assembled actuator rod (item 10). Attach the actuator to the deflector bracket (item 5) and to the base bracket (item 7), with two 1" pins (item 8) and secure with two hairpins (item 9).
- 5. Figure 20:** Open deflector completely, making sure the actuator is completely closed. Place the base bracket (item 7) in the rear center of the chute. Using the bracket as a template, drill four 1/2" holes in the chute.
- 6. Figure 20:** Attach the base bracket with four 5/16" allen flat head setscrews (item 4) and 5/16" serrated flange nuts (item 6) placing the setscrew head inside the chute. Tighten until the setscrew head sinks into the inside surface.

For Chute with telescopic adjustment rod:

Figure 20A: Install the pre-assembled actuator (item 10) on the chute in the illustrated position with two 1" pins (item 8) and secure with two 4mm x 80mm hairpins (item 9).

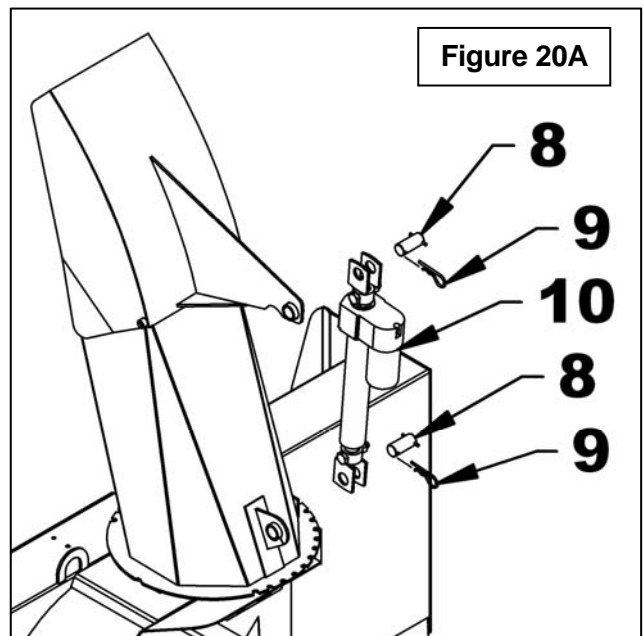
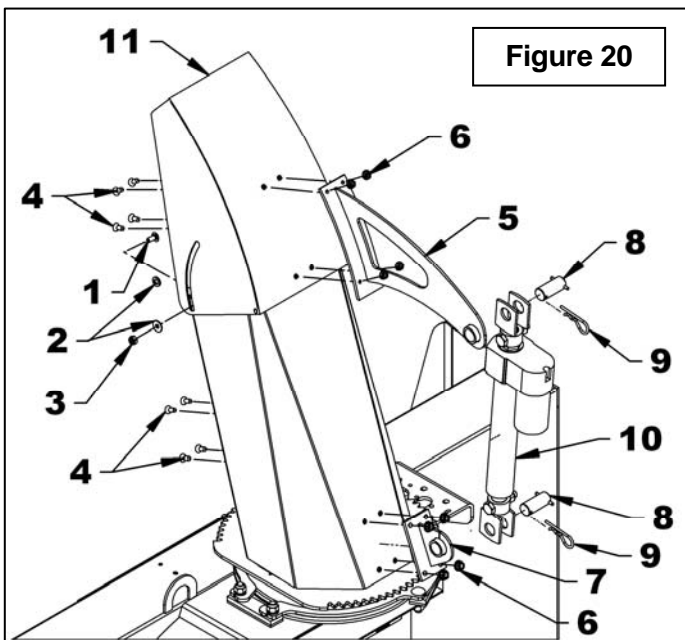

ASSEMBLY

7. **Figure 21:** Insert the switch (item 1) in the switchbox (item 2), secure with the two nuts (items 3) provided with the switch, and screw the rubber cap (item 4) in the order shown on figure. Insert the plastic cap (item 5) in the free hole of the switchbox (if needed).
8. **Figure 21:** Install the switchbox at a convenient location for easy access when operating the snowblower. Secure using three #10 x 1/2" self-drilling screws (item 6). Leave a hole to install the ground wire. Avoid placing the switch box where wires are already installed as they could be damaged.
9. **Figure 19:** Connect the ring terminal of the ground wire (item 1) to a ground screw of the vehicle.
10. **Figure 19:** Connect the fuse wire (item 3) to the tractor switch wire using a tap connector (item 5).
11. **Figure 19:** Connect the actuator double wire (item 4) to the actuator (item 7).
12. **Figure 19:** Cover all wires with the loom (item 6) and attach with tie wrap.

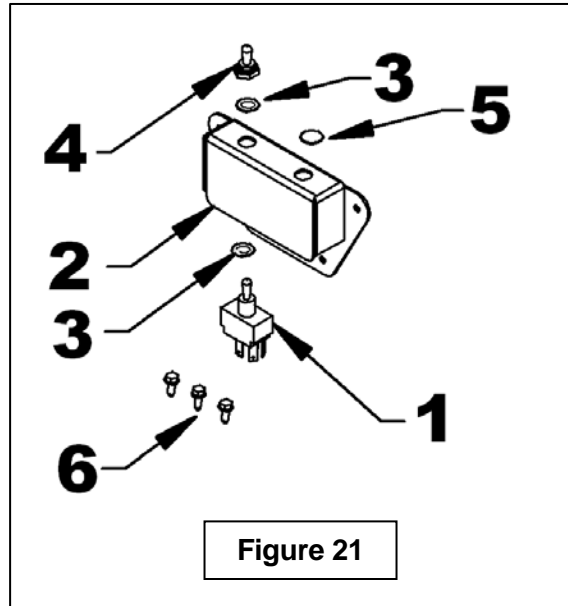

ASSEMBLY

IMPORTANT:

A proper initial installation will give you years of satisfactory service on your equipment. Please read carefully following instructions that have been specially included to help you and ensure you are satisfied with your purchase.



WARNING

Unfortunately, snowblowers will be faced with forgotten or hidden objects under the snow, such as : chain, tires, stones, pieces of wood, etc. In spite of all our efforts, machines are not built to resist all those conditions.

How to Determine Driveline Angles

IMPORTANT: To obtain the proper universal joint angles, it is recommended to adjust the three point hitch at the furthest point from the tractor recommended by the manufacturer

Danger: Tractors Too Big

It is dangerous to use a tractor that is too big and powerful. The tractor will always be able to overload the blower, even if the machine is already at maximum capacity. Furthermore, tractors being very high, the driveline angles will be excessive which means the universal joints will be very vulnerable and the life of the driveline will be dramatically reduced.

The universal joint angle is directly related with the life of driveline. In order to reduce the angle, it is necessary to increase the distance between the snowblower and the tractor.

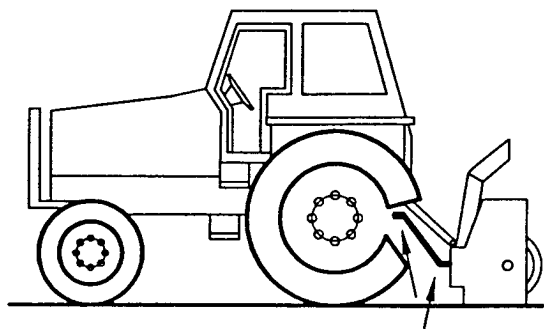

Angles of Driveline Joints Too Large
Avoid

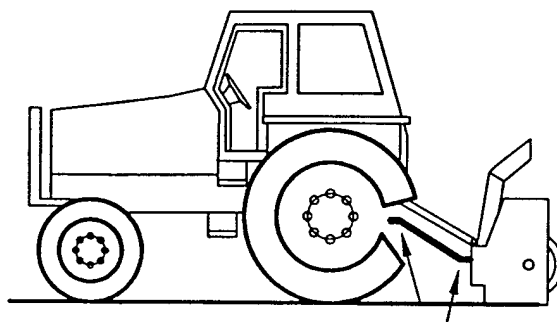

Reasonable Angles of Driveline Joints
Acceptable

ASSEMBLY

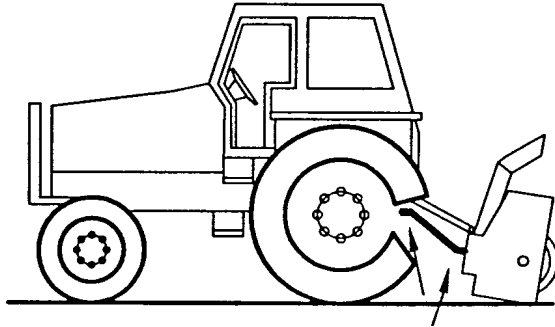

Unequal Angles at Driveline Joints
Avoid

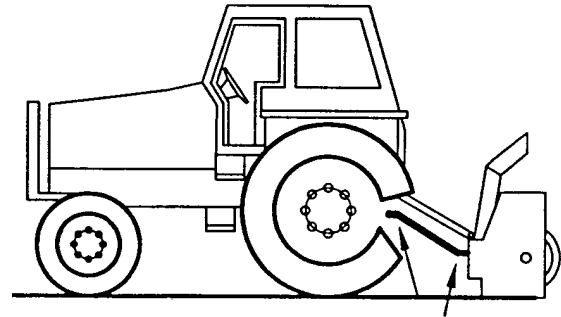

Equal Angles at Driveline Joints
Recommended

Angles at Each End of Driveline

A popular habit is to change the snowblower angle in order to obtain a better scraping effect. This practice can become harmful to the driveline since the angle at each end is unequal. This results in a fan speed variation as well as a drastic increase of load on cross and bearings. To be avoided: It is recommended to always keep tractor driveline and snowblower input shaft parallel.

Determining Driveline Length

IMPORTANT: Before using the equipment, make sure the driveline is not too long. At working position, the two half drivelines must intersect each other sufficiently to insure maximum efficiency but there must not be any interference.

1. To determine the "L" length for your tractor model first find the "X" factor (figure 22) by measuring the horizontal distance between the end of the tractor's drive shaft and the end of the snowblower's driven shaft when the snowblower is in transport position as shown on figure.
2. Choose in the table below the "Y" factor according to the tractor category and deduct that number from "X" (figure 22) to determine "L" (figure 23) which is the center-to-center length between the universal joints.

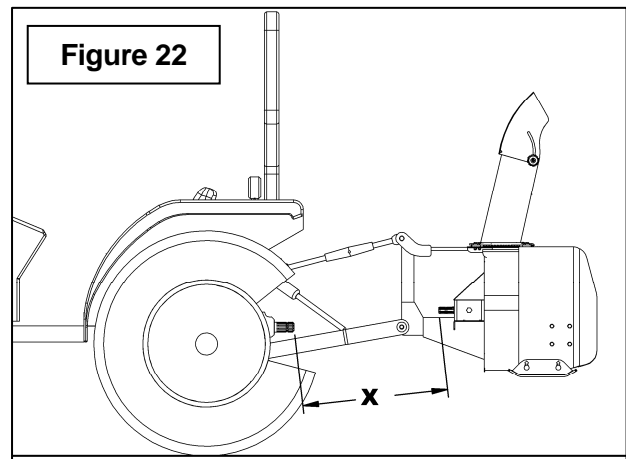

$$L = X - Y$$

3 PTS HITCH CATEGORY	Y
Cat. 1	4 1/2"
Cat. 2	5 1/2"

ASSEMBLY

NOTE: Before cutting, make sure the two shafts intersect by at least 7 3/4" when in working position that is when the snowblower rests on the ground.

3. **Figure 23:** Hold the two half-shaft side by side and locate the "L" length between the two center-to-center half-shaft universal joints. Mark off the zone to be cut on both halves opposite each half-shaft guard as shown on Figure.
4. **Figure 23A:** Cut off inner and outer guard tubes as well as the inner and outer telescopic sections.
5. **Figure 23A:** Cut the guard a second time leaving the same distance between the end of the guard and the end of the shaft as existed before. To obtain the proper distance "A" shown on Figure 23A cut the guard according to the following table:

DISTANCE A	
Male PTO	Female PTO
1 3/4"	1 1/4"

6. **Figure 23A:** File down tubes and remove chips.
7. Apply grease to inside of outer telescopic section.

IMPORTANT: Work with fully guarded shafts only.

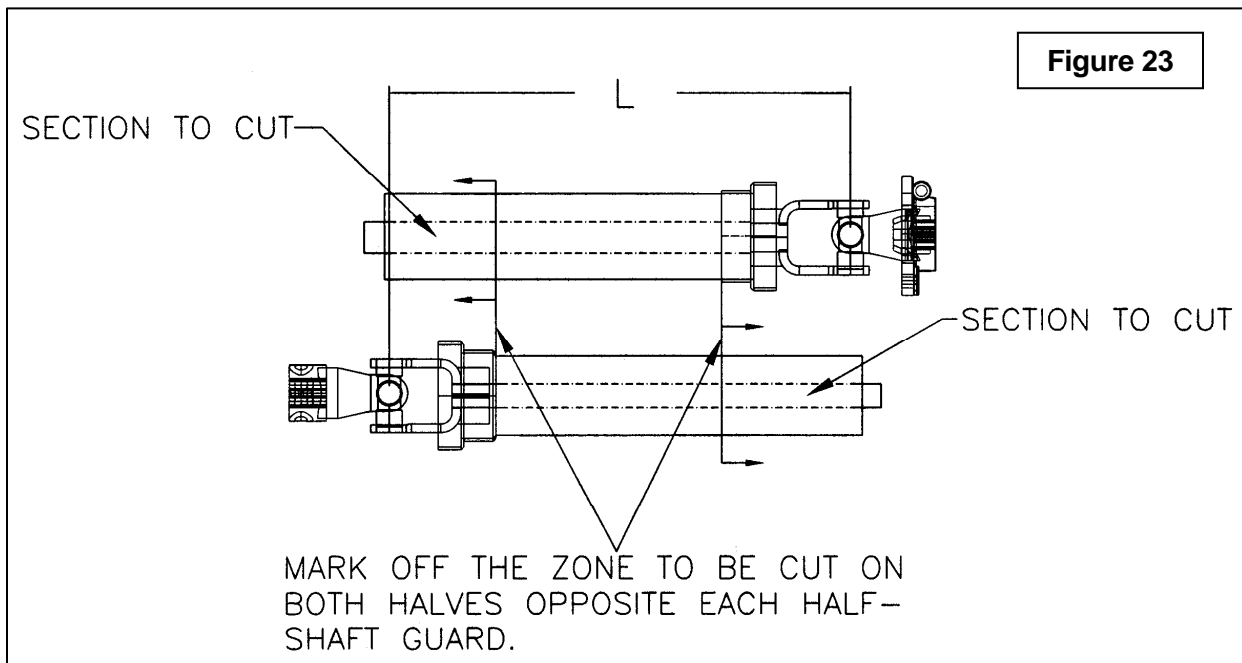
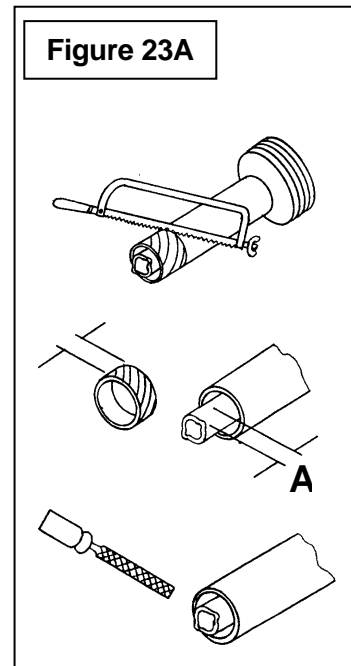

ASSEMBLY

Driveline Installation

(Figure 24)

1. Separate the snowblower from the three point or quick hitch.
2. Remove paint from snowblower gearbox shaft (item 1) and grease driveline sliding surfaces and yoke (item 2).
3. Remove the bolts (items 3) from the driveline yoke (item 2) and slide yoke over drive shaft using the sliding action of the driveline. Make sure the driveline is well secured to the shaft by reinstalling the bolts and nuts (item 3-4) in the order shown. Tighten the bolts according to the **Torque Specification Table** at the end of manual.
4. Attach safety chain (item 5) around the upper link (item 6) to prevent the guard from spinning.

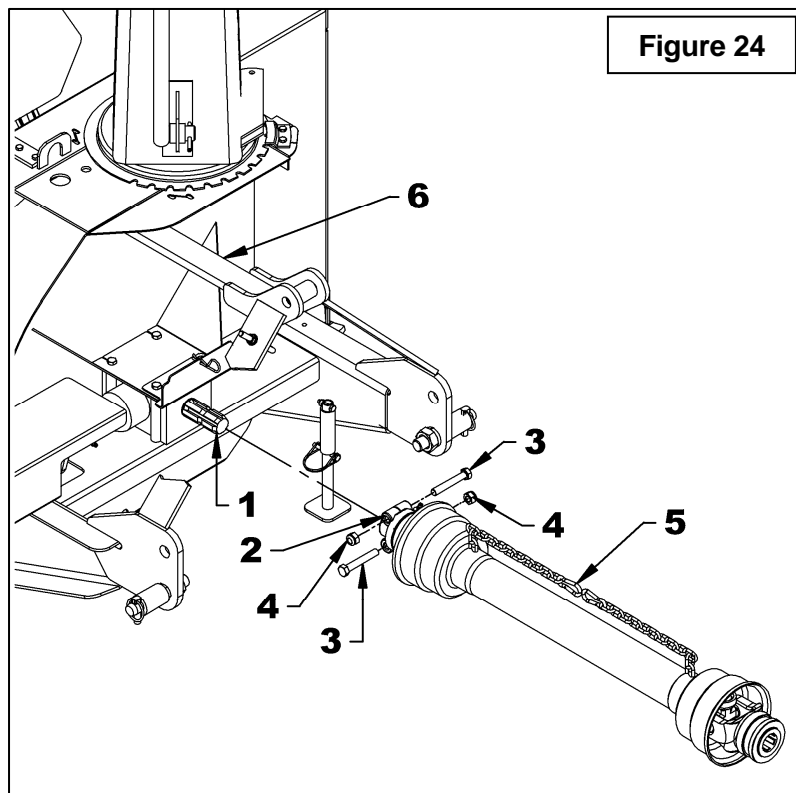

ASSEMBLY

Removing Snowblower from Tractor (Figures 25 to 28)

Three Point Hitch

1. Set parking brake and turn engine off.
2. **Figure 25:** Remove the wire round lock pin (item 2), lower the parking stand (item 1) completely to the ground to release all pressure from the three-point and reinsert the wire round lock pin in the lower hole (item 3).
3. **Figure 26:** Detach upper link (item 4) by removing linchpin and pin (items 6-5).
4. **Figure 26:** Disconnect driveline from tractor and attach the driveline safety chain (item 7) to the three point hitch eyebolt (item 8).
5. **Figure 26:** Carefully detach lower links (items 2) from hitch pins (item 1) by removing linchpins (items 3), loosen anti-sway turnbuckles and slowly back tractor away from the snowblower.

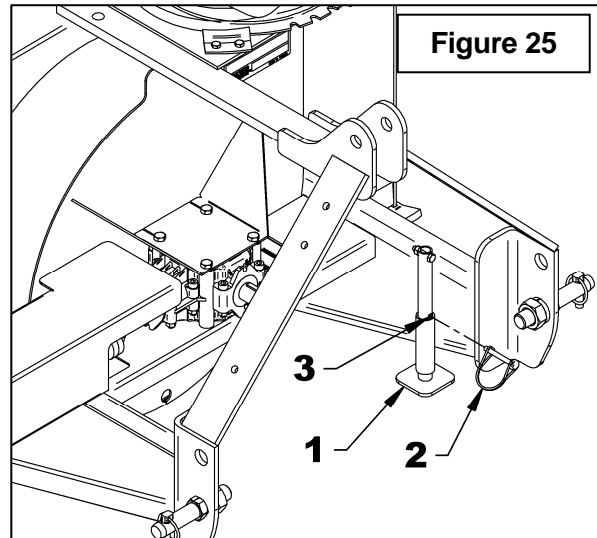

IMPORTANT: To avoid damages to the snowblower, retorque all bolts after the first 10 hours of operation.

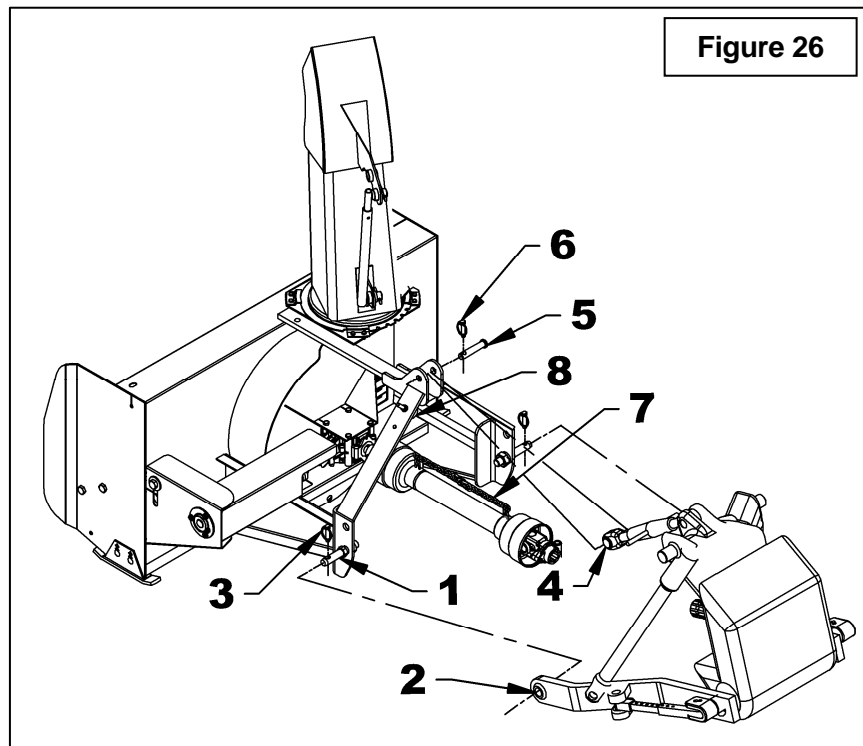

ASSEMBLY

Quick Hitch

1. Set parking brake and turn engine off.
2. **Figure 27:** Remove the wire round lock pin (item 2), lower the parking stand (item 1) and reinsert the wire round lock pin in the lower hole (item 3).
3. **Figure 28:** Disconnect driveline (item 1) from tractor and attach the driveline safety chain (item 2) to the three point hitch eyebolt (item 3).
4. **Figure 28:** Slowly back the tractor away to release quick hitch (item 4) from the snowblower.

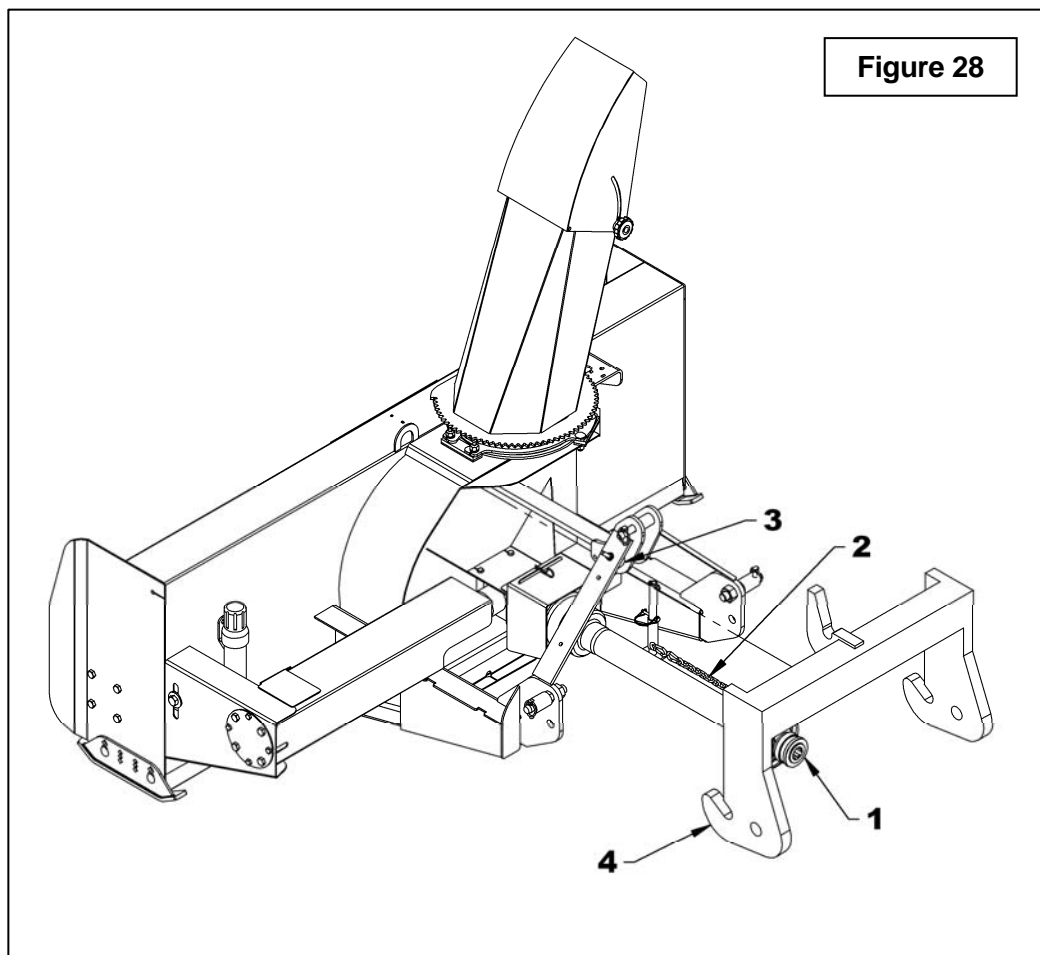
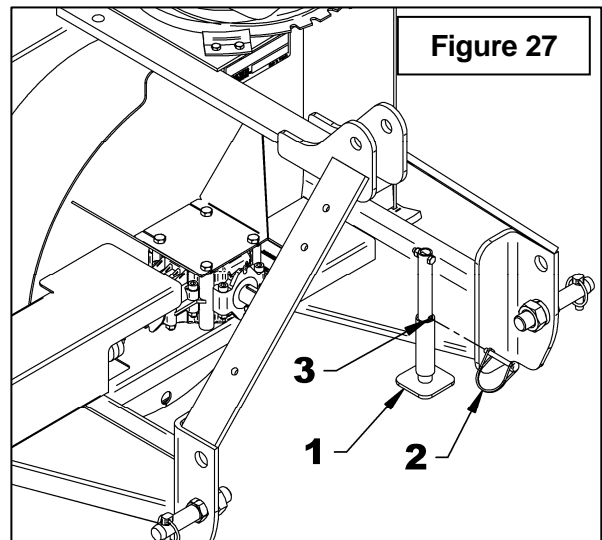

OPERATION

GENERAL PREPARATION

1. Read the operator's manual carefully before using the tractor and snowblower. Be thoroughly familiar with the controls and proper use of the equipment. Know how to stop the unit and disengage the controls quickly.
2. Make sure the snowblower is clear of snow before engaging the driveline.
3. Make sure the auger and fan operate freely.
4. Check the oil level in the worm Gearbox and if necessary, add 80W90 SAE gear oil, AGMA 5EP oil or equivalent.
5. Check the two shear bolts, one on the driving shaft, and the one on the PTO, for proper tightness.
6. Adjust so that the snowblower skid shoes run level.
7. Wear adequate winter outer garments while operating equipment.

OPERATING CONTROLS

Work and Travel Speed

Working ground speed will depend on the depth and density of the snow to be cleared. Normally, ground speed will range from 4 to 7 MPH for light, dry snowfalls 3 to 6 inches, and 1 to 3 MPH for heavy, wet or drifted snow. To transport, disengage the drive shaft and raise the snowblower to full transport height.

Raising and Lowering the Snowblower

Move the three point lever on right hand side of seat down or forward to lower, and up or rearward to raise.



WARNING

To avoid personal injury, be sure the tractor engine is off, the drive shaft disengaged, and all movement has stopped before making any adjustments.

ADJUSTMENTS

Chain Tension Adjustment (Figure 29)

The premature wear of the chain may be caused by tension being too tight. It is therefore important not to tighten chain to its maximum.

- To adjust the tension on the drive chain, loosen the bolt (item 1), securing the idler sprocket to the snowblower housing.
- To tighten the chain, lower the bolt. Leave approximately 1/8" deflection in one span of the chain. Retighten securely the bolt holding the idler sprocket.

Skid Shoe Adjustment (Figure 29)

Adjust the skid shoes so that the snowblower runs level and according to the surface conditions so that stones are not thrown with the snow.

Adjust both skid shoes to the same height to keep the cutting edge level and adjust upwards for smooth surfaces.

Loosen skid shoe bolts (item 2) and adjust according to instructions below, and securely tighten bolts:

Clearance between cutting edge and surface:

- *Paved surface:* Insert bolts in lower hole.
- *Uneven or gravel surface:* Insert bolts according to distance needed:
1/2" - middle hole
1" - upper hole

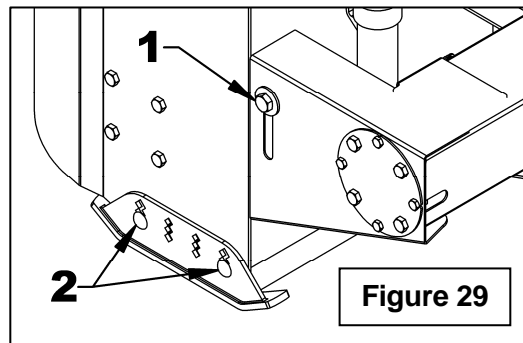

Figure 29

Manual Deflector Adjustment

Set the angle of deflection according to the distance the snow must be thrown. To set the deflector angle, loosen the deflector knobs located on the side of the deflector and adjust the deflector to the appropriate angle. Retighten the knobs.

OPERATION

SNOW REMOVAL METHODS

When removing snow, do not use the snowblower as a dozer blade to push snow. Let the snowblower work its way through deep drifts. If the speed of your tractor is too fast, the snowblower may become overloaded and clog. For best results, raise the snowblower and remove a top layer of snow. A second pass with the snowblower will remove the remaining snow.

IMPORTANT: Use full RPM power when removing wet, sticky snow. Low RPM power will tend to clog the chute.



Do not use hands or feet to unclog chute. Do not attempt to clear clogged chute of snow while tractor engine is running. If the chute clogs, disengage the drive shaft, shut off the tractor engine, remove the ignition key, wait for all movement to stop, and then clear the snow from the chute.

A definite pattern of operation is required to thoroughly clean the snow area. These patterns will avoid throwing snow in unwanted places as well as eliminating a second removal of snow

PATTERN 1

DISCHARGE SNOW BOTH SIDES

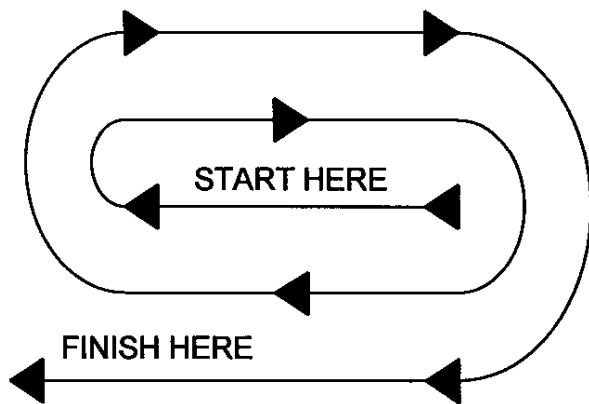

DISCHARGE SNOW BOTH SIDES

PATTERN 2

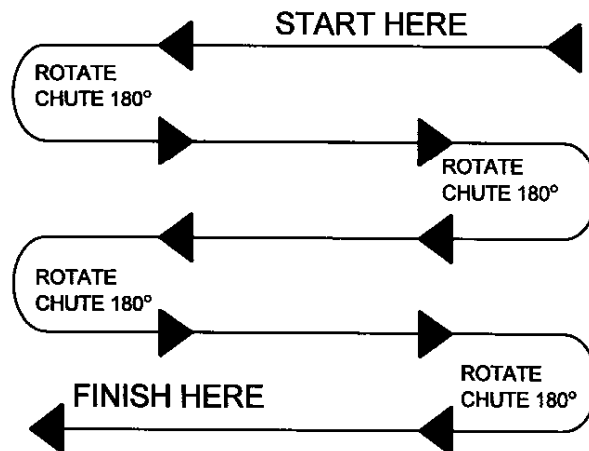

DISCHARGE SNOW THIS SIDE ONLY

Where it is possible to throw the snow to the left and right (above), as on a long driveway, it is advantageous to start in the middle. Plow from one end to the other, throwing snow to both sides without changing the direction of the discharge guide

If the snow can only be thrown to one side of the driveway or sidewalk (above), start on the opposite side. At the end of the first pass, rotate the discharge guide 180 degrees for the return pass. At the end of each succeeding pass, rotate the discharge guide 180 degrees to maintain direction of throw in the same area.

MAINTENANCE

MAINTENANCE

Shearbolts

Check the shearbolts indicated on the figure below at frequent intervals for proper tightness to be sure the blower is in safe working condition.

Figure 30: To access the shear bolts, pull up the access pannel (item 1) located near the chain. If the shearbolts need replacement, use the following parts only:

Drive shaft:

Shearbolt hex. 1/4" NC x 1 1/4" gr.2, incl. nut.
Part # 669345.

Driveline:

Shearbolt M8 x 1.25 x 50mm gr. 6.6 and nut.
Part # 4700060.



WARNING

Provide adequate blocking before working under the snowblower when in the raised position.

Driveline

IMPORTANT: When the snowblower is not used for more than two weeks, perform driveline maintenance and always store it in a dry place, away from bad weather conditions.

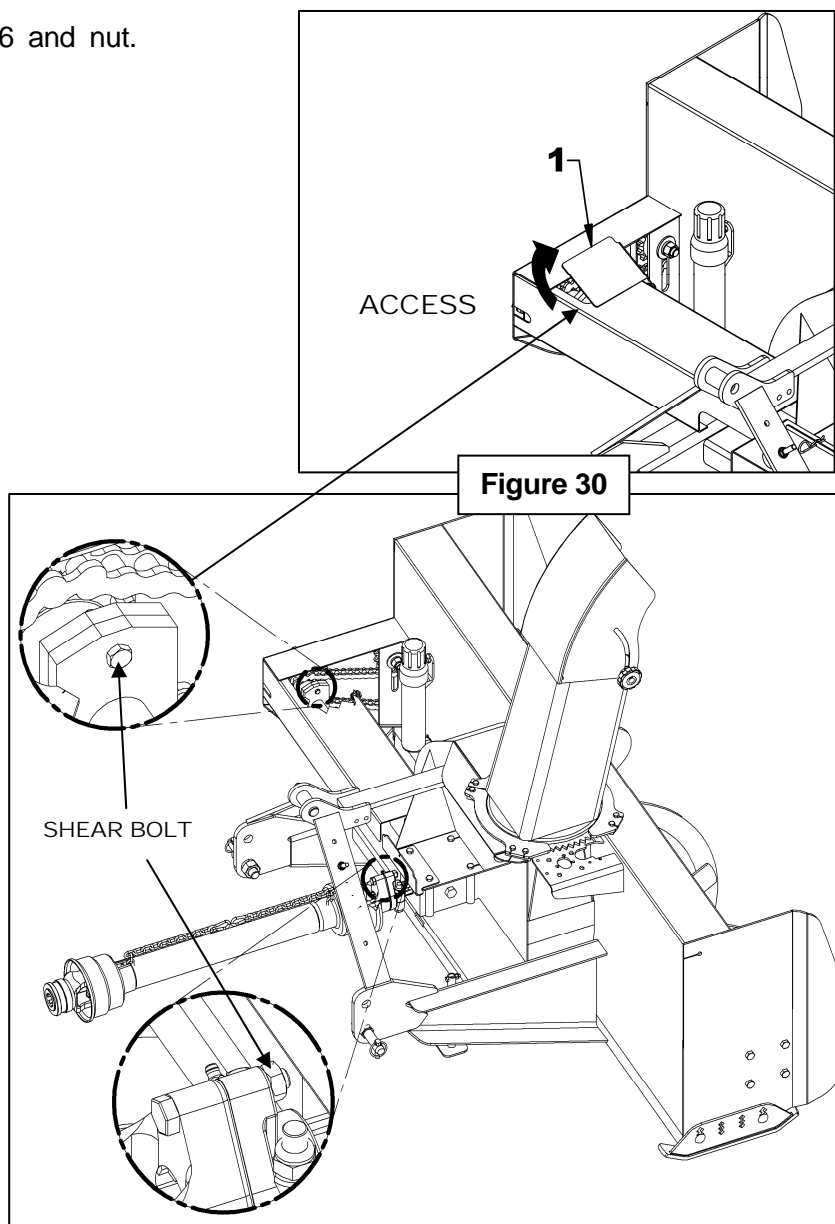

MAINTENANCE

LUBRICATION

Use oil or a grease gun and lubricate as follows:

DESCRIPTION	INTERVAL	LUBRICATION REQUIRED
Driveline	8 hours	Grease each universal joint. Separate the sliding parts and cover each one of them with grease
	16 hours	Oil the push pins
Chain	4 hours and after each operation	Lubricate with chain lube
Drive Shaft	24 hours of operation	Grease fitting on shear plate
Gearbox	Every month	Check oil level. If needed, add AGMA 5EP extreme pressure oil, SAE 80W90 gear oil or equivalent.
	Once a year	Replace oil
Bearing	24 hours of operation	Grease each auger and drive shaft bearing

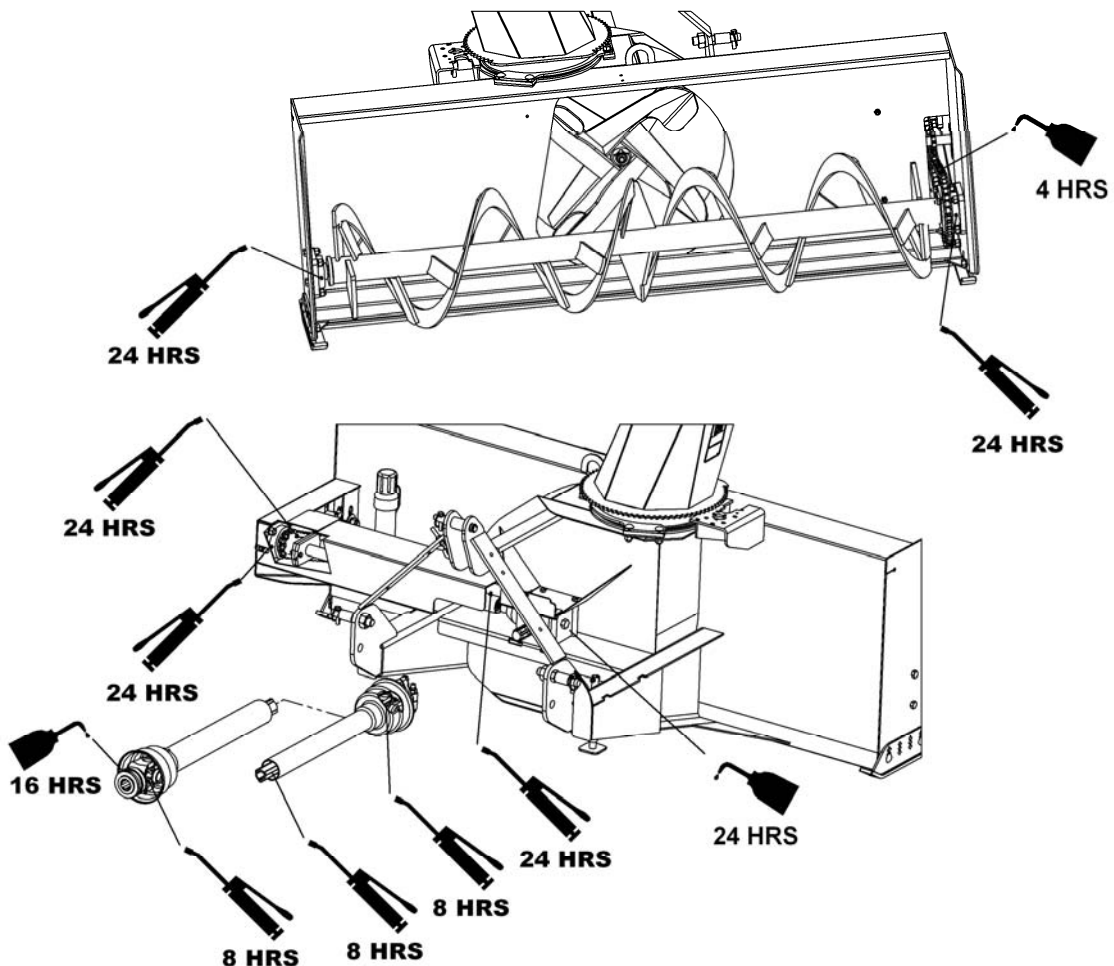

MAINTENANCE

DRIVELINE TROUBLESHOOTING

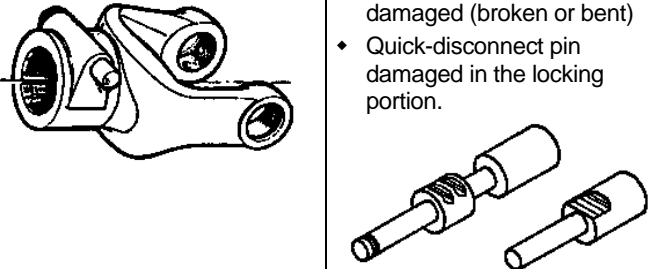
	AVOIDABLE DAMAGES	POSSIBLE CAUSES	CORRECTIVE ACTIONS
<p><u>QUICK-DISCONNECT YOKE</u></p> 	<ul style="list-style-type: none"> Quick-disconnect pin tight or completely seized. Quick-disconnect pin damaged (broken or bent) Quick-disconnect pin damaged in the locking portion. 	<ul style="list-style-type: none"> Quick-disconnect pin dirty (insufficient maintenance). Quick-disconnect pin defective (forced engagement, incorrect handling) Excessive shaft length. Axial loads too high. 	<ul style="list-style-type: none"> Clean, oil and follow service instructions. Replace quick-disconnect pin. Shorten shaft length (cut both telescopic tubes as well as shield and remove burrs). Replace quick-disconnect pin. Clean and grease telescopic tubes, and replace both tubes, if necessary. Replace quick-disconnect pin.



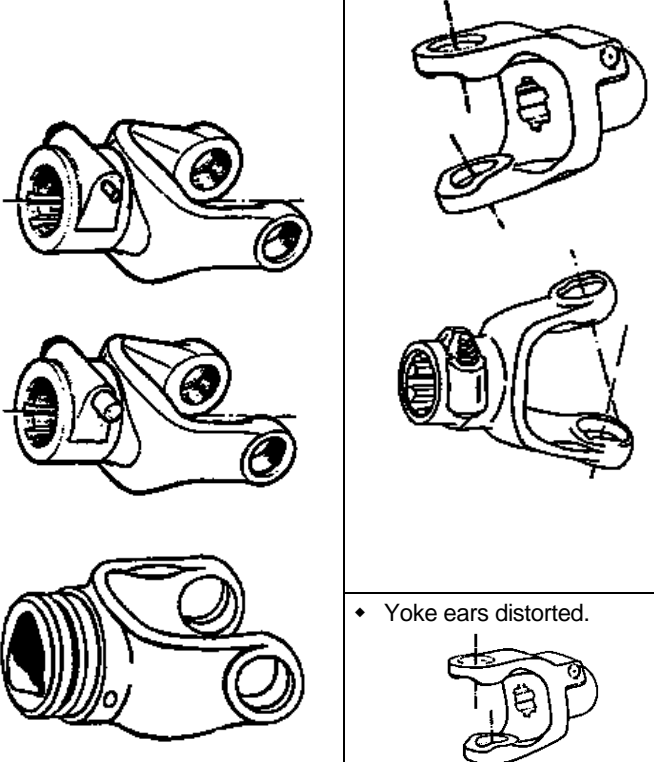

Note: Quick-disconnect pins must be cleaned and greased every 16 hours.

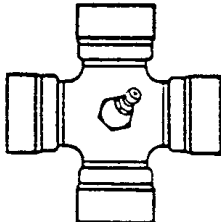
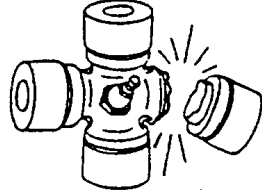
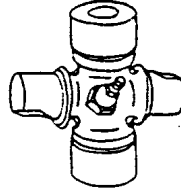
	AVOIDABLE DAMAGES	POSSIBLE CAUSES	CORRECTIVE ACTIONS
<p><u>YOKE</u></p> 	<ul style="list-style-type: none"> Yoke ears deformation 	<ul style="list-style-type: none"> Excessive shaft length. Axial loads too high. Excessive working angle and torque. 	<ul style="list-style-type: none"> Shorten shaft length (cut both telescopic tubes as well as shields and remove burrs). Replace defective yokes. Clean and grease telescopic tubes, and replace both tubes, if necessary. Replace defective yokes. Verify compatibility between shaft and working conditions (torque vs. angle). Disengage tractor driveline during cornering or when lifting or lowering the implement. Change to a larger driveline size. Replace defective yokes.
	<ul style="list-style-type: none"> Yoke ears distorted. 	<ul style="list-style-type: none"> Overload caused by high starting and peak torques. 	<ul style="list-style-type: none"> Engage driveline more carefully. Use appropriate safety devices. Replace defective yokes.
	<ul style="list-style-type: none"> Yoke ears worn or pounded. 	<ul style="list-style-type: none"> Excessive working angle. 	<ul style="list-style-type: none"> Avoid excessive working angle. Disengage tractor driveline during cornering. Replace defective yokes.

MAINTENANCE

	AVOIDABLE DAMAGES	POSSIBLE CAUSES	CORRECTIVE ACTIONS
<p><u>CROSS KIT</u></p> 	<ul style="list-style-type: none"> ◆ Cross arms broken. 	<ul style="list-style-type: none"> ◆ Extreme torque peak or shock load. ◆ Axial loads too high. 	<ul style="list-style-type: none"> ◆ Use appropriate safety device. ◆ Change to a larger driveline size. ◆ Shorten driveline shaft. ◆ Replace defective cross bearings.
	<ul style="list-style-type: none"> ◆ Bearing caps turning in their cross journal. ◆ Overheated bearing caps. 	<ul style="list-style-type: none"> ◆ Excessive continuous torque and/or excessive working angle. ◆ Inadequate greasing. 	<ul style="list-style-type: none"> ◆ Verify compatibility between shaft and working conditions. ◆ Carefully follow greasing instructions. ◆ Replace defective cross bearings.
	<ul style="list-style-type: none"> ◆ Accelerated wear of cross kit. 	<ul style="list-style-type: none"> ◆ Excessive continuous torque and/or excessive working angle. ◆ Inadequate greasing. 	<ul style="list-style-type: none"> ◆ Verify compatibility between shaft and working conditions. ◆ Carefully follow greasing instructions. ◆ Replace defective cross bearings.

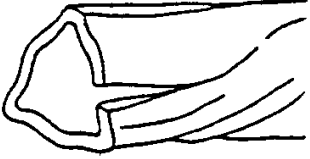
Note: Cross bearings must be greased every 8 working hours.

	AVOIDABLE DAMAGES	POSSIBLE CAUSES	CORRECTIVE ACTIONS
<p><u>TELESCOPIC TUBES</u></p>  	<ul style="list-style-type: none"> ◆ Telescopic tubes failure or twisting. 	<ul style="list-style-type: none"> ◆ Extreme torque peak or shock load. ◆ Short tube engagement. 	<ul style="list-style-type: none"> ◆ Use appropriate safety device. ◆ Change to a larger driveline size. ◆ Replace the driveline drive shaft with one having adequate length. ◆ Replace defective tubes.
	<ul style="list-style-type: none"> ◆ Accelerated wear of telescopic tubes. 	<ul style="list-style-type: none"> ◆ Extreme load when sliding. ◆ Short tube engagement. ◆ Inadequate greasing. ◆ Dirt 	<ul style="list-style-type: none"> ◆ Change to a driveline with rilsan coated inner tube. ◆ Replace the driveline with one having adequate length. ◆ Carefully follow greasing instructions. ◆ Replace defective tubes.

Note: Telescopic tubes must be cleaned and greased every 8 working hours.

MAINTENANCE

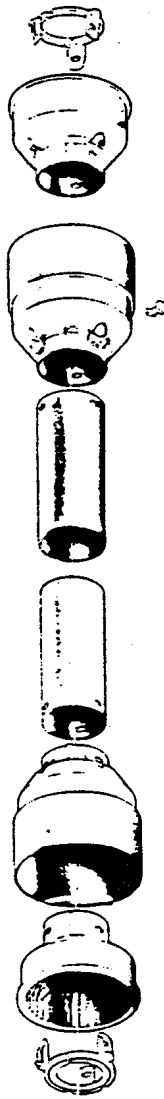
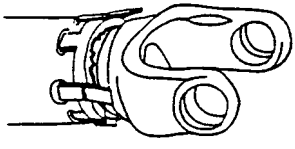
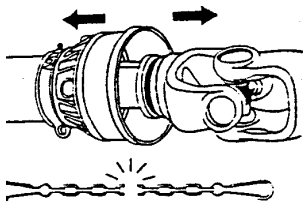
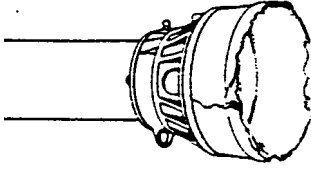
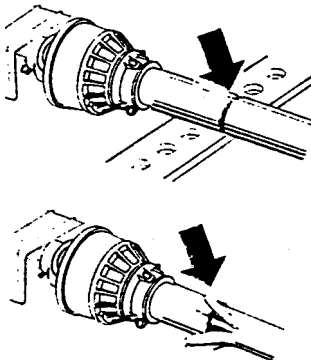
SHIELD 	AVOIDABLE DAMAGES	POSSIBLE CAUSES	CORRECTIVE ACTIONS
	<ul style="list-style-type: none"> ◆ Excessive wear of shield bearings. 	<ul style="list-style-type: none"> ◆ Insufficient lubrication. ◆ Incorrect chain mounting. ◆ Shield interfering with implement. 	<ul style="list-style-type: none"> ◆ Follow lubrication instructions. ◆ Mount chain to allow maximum angularity. ◆ Avoid contact of the shields with fixed parts of the machine or tractor. ◆ Replace shield bearings.
	<ul style="list-style-type: none"> ◆ Chain moving or failure. 	<ul style="list-style-type: none"> ◆ Shield interfering with implement. ◆ Incorrect chain mounting. 	<ul style="list-style-type: none"> ◆ Avoid contact of the shields with fixed parts of the machine or tractor. ◆ Mount chain to allow maximum angularity. ◆ Replace defective parts.
	<ul style="list-style-type: none"> ◆ Shield cone damaged. 	<ul style="list-style-type: none"> ◆ Shield cone in contact with components on the tractor and/or implement. ◆ Excessive angularity. 	<ul style="list-style-type: none"> ◆ Eliminate interference between Shield cones and any part on the tractor and/or implement. ◆ Avoid excessive angle during cornering or when lifting or lowering the implement. ◆ Replace damaged Shield cones.
<ul style="list-style-type: none"> ◆ Shield tubes damaged (deformed and split at one side). 	<ul style="list-style-type: none"> ◆ Shields in contact with components on the tractor and/or implement. ◆ Shield tubes overlap too short or no overlap at all with extended driveline. 	<ul style="list-style-type: none"> ◆ Eliminate interference between Shield cones and any part on the tractor and/or implement. ◆ Replace damaged tubes. ◆ Adjust Shield tubes length with longer tubes. 	

Note: Shield bearings must be greased every 8 working hours.

PARTS

INTRODUCTION

All parts are illustrated in "exploded views" which show the individual parts in their normal relationship to each other. Reference numbers are used in the illustrations. These numbers correspond to those in the "Reference Number" (REF) column, and are followed by the description and quantity required.

Right Hand and Left Hand are determined by those seen by the conductor standing behind the equipment.

The manufacturer reserves the rights to change, modify, or eliminate from time to time, for technical or other reasons, certain or all data, specifications, or the product or products themselves, without any liability or obligation.

The parts listed here are available through your local dealer.

MANUAL HOLDER – ALL MODELS

REF.	DESCRIPTION	QTY	PART #
1	Manual holder	1	4200030
2	Bolt hex. 5/16" NC x 3/4" lg gr. 5, PTD	2	0100018
3	Nut nylon insert 5/16" NC, PTD	2	1000005

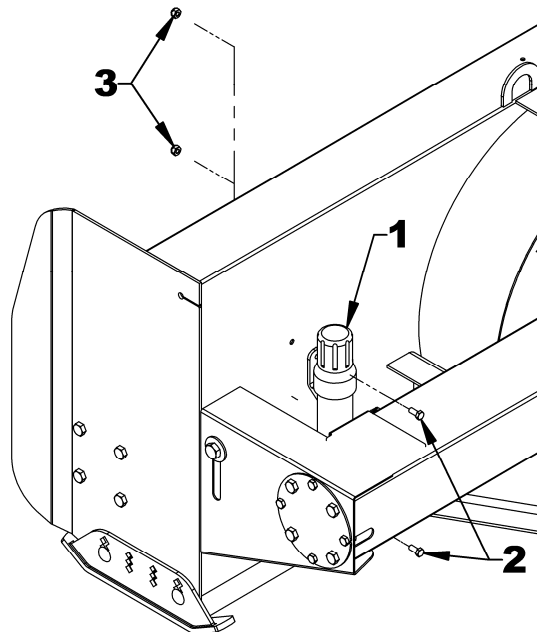

PARTS

SNOWBLOWER – B74C

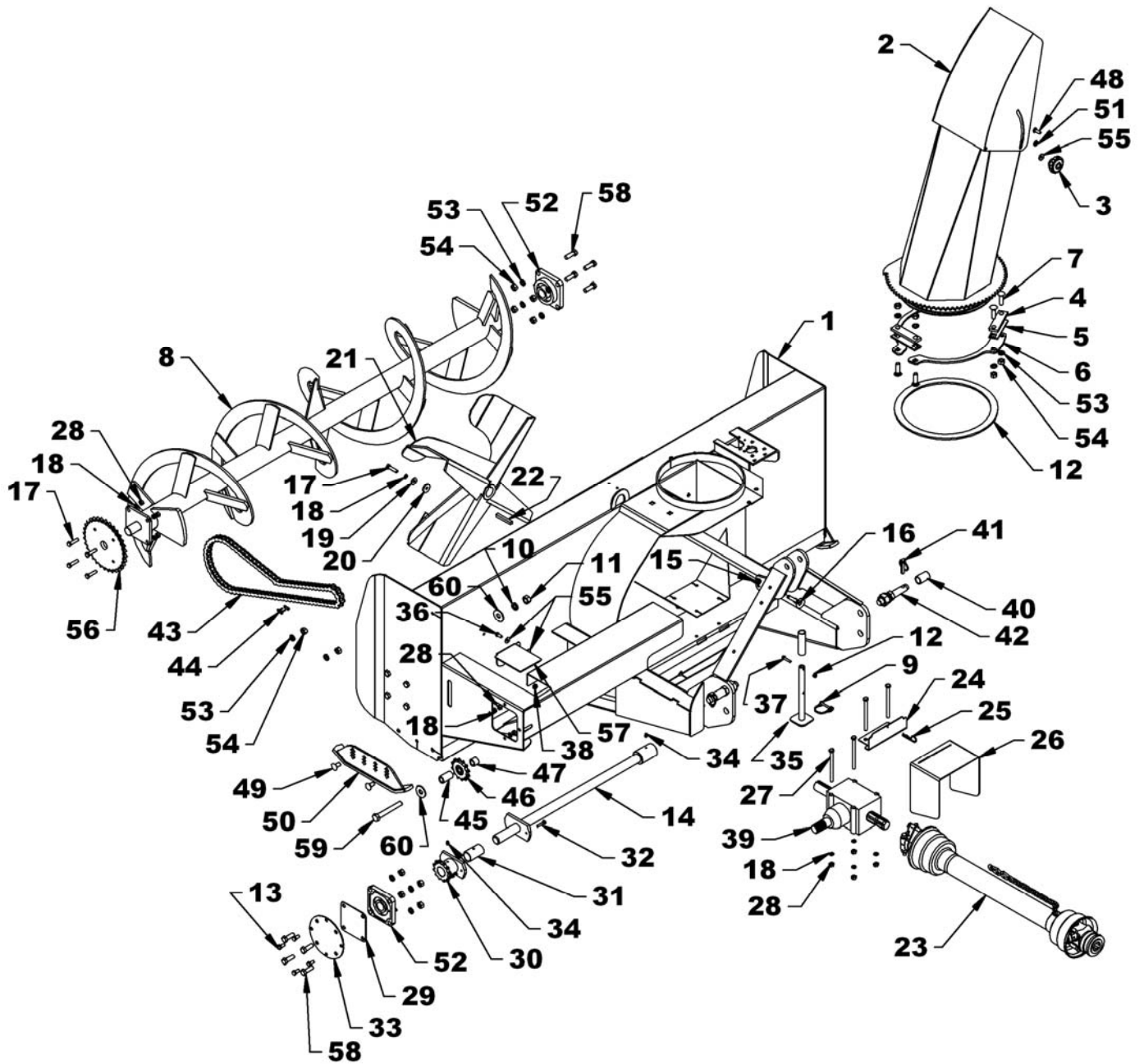

PARTS

SNOWBLOWER – B74C

REF.	DESCRIPTION	QTY	PART #
1	Housing	1	---
2	Chute (including decals)	1	669782
3	Knob	2	657309
4	Spacer 3/8" thick x 1.25" larg. x 4.5 lg	3	669178
5	Spacer 3/16" thick x 1.25" larg. x 4.5 lg	3	669179
6	Retaining plate	2	665935
7	Carriage bolt 1/2" NC x 1 3/4" gr.5 PTD	6	0300025
8	Auger	1	666271
9	Round wire lock pin 1/4" x 2" PTD	1	1900006
10	Lockwasher 5/8" PTD	1	1200007
11	Nut hex. 5/8" NC gr.5 PTD	1	0900007
12	Rotation bushing	1	662834
13	Bolt hex. 3/8" NC x 3/4" lg gr.5 PTD	4	0100037
14	Drive shaft	1	669720
15	Serrated flange nut 3/8" NC PTD	1	0900035
16	Eyebolt 3/8" NC x 4" lg w/ nut	1	0400027
17	Bolt hex. 3/8" NC x 1 1/2" gr.5 PTD	5	0100040
18	Lockwasher 3/8" PTD	13	1200004
19	Flat washer 3/8"	1	1400003
20	Fan washer	1	661554
21	Fan	1	668966
22	Key 3/8" x 3/8" x 2 3/4" lg	1	654174
23	Driveline Series 40	1	4700159
24	Driveline shield bracket	1	668097
25	Hairpin 3mm x 65mm lg PTD	1	1800004
26	Driveline shield	1	668057
27	Bolt hex. 3/8" NC x 5" gr.5 PTD	4	0100051
28	Nut hex. 3/8" NC gr.5 PTD	12	0900003
29	Spacer plate	1	669722
30	Shear plate	1	669595
31	Oilite bushing	1	4300072
32	Shearbolt 1/4"NC x 1 1/4" gr.5, incl. nut	1	669596
33	Driving shaft support	1	669356
34	Grease fitting 1/4" NF	2	654106
35	Parking stand	1	668053
36	Bolt hex. 5/16" NC x 3/4" lg gr.5 PTD	1	0100018
37	Bolt hex. 1/4" NC x 1 1/4" gr. 5 PTD	1	0100005
38	Nylon insert locknut 5/16 NC PTD	1	1000005
39	Gearbox	1	663485
40	Bushing 1 1/8" ext. x 1 3/4" lg PTD	2	4600045
41	Linchpin 7/16" PTD	2	1900003
42	Hitch pin 7/8" x 5 1/2" lg Cat. 1	2	654196
43	Chain #60 x 78 links	1	654009

PARTS

SNOWBLOWER – B74C

REF.	DESCRIPTION	QTY	PART #
44	Coupling link #60	1	654839
45	Spacer ring .656"ID x 1.760 x 1" ext.	1	668093
46	Idler sprocket 60A12	1	3300022
47	Spacer ring .656"ID x .807 x 1" ext.	1	667777
48	Carriage bolt 5/16" NC x 1" gr.5 PTD	2	0300003
49	Carriage bolt 1/2" NC x 1" lg gr.5 PTD	4	0300022
50	Adjustable skid shoe	2	669586
51	Nylon flat washer 7/16" hole	2	658468
52	Flange bearing 1 1/4" hole, 4 holes	3	4300001
53	Lockwasher 1/2" PTD	18	1200006
54	Nut hex. 1/2" NC PTD	22	0900006
55	Nylon flat washer 11/32" hole	4	658467
56	Sprocket 60A32	1	654167
57	Access plate	1	669597
58	Bolt hex. 1/2" NC x 1 1/2" lg gr.5 PTD	12	0100070
59	Bolt hex. 5/8" NC x 4 1/2" lg gr.5 PTD	1	0100104
60	Flat washer 5/8" (11/16" dia. trou)	2	1400008

PARTS

GEARBOX 663485

REF.	DESCRIPTION	QTY	PART #
1	Casing	2	659848
2	Bearing	2	659844
3	Shim	1	656649
4	Input shaft	1	664663
5	Shim	2	659855
6	Oil seal	3	659852
7	Snap ring	2	656652
8	Gear	2	662236
9	Parallel key	2	659850
10	Output shaft	1	659853
11	Bearing	2	659844
12	Plug	1	659847
13	O-ring	1	661144
14	Allen socket head cap screw M8 x 1.25mm x 55mm – 8.8.	8	0800032
15	Stover locknut M8 x 1.25mm - 8	8	0900063
16	Shim	1	659854

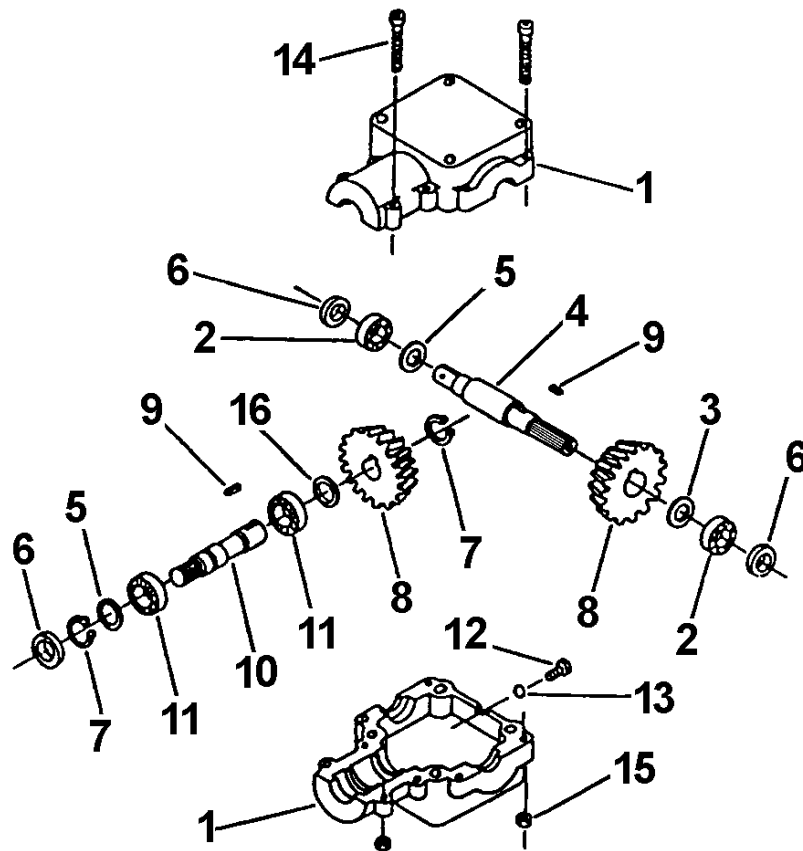

PARTS

DRIVELINE 4700159

REF.	DESCRIPTION	QTY	PART #
1	Yoke ass'y	1	660764
2	Journal cross	2	660765
3	Yoke for female tube	1	663189
4	Female tube	1	4700160
5	Male tube	1	4700161
6	Yoke for male tube	1	663193
7	Yoke ass'y	1	4700058
8	Bolt M12 x 1.25 x 70 with nut	2	662199
9	Grease fitting	1	663129
10	Ball Ø1/4"	23	663163
11	Shear bolt 8mm x 1.25 x 50 gr.5.8 and nut	1	4700060
12	Protector and chain	1	4700164
13	Pin for outer tube	1	4700061
14	Pin for inner tube	1	4700062

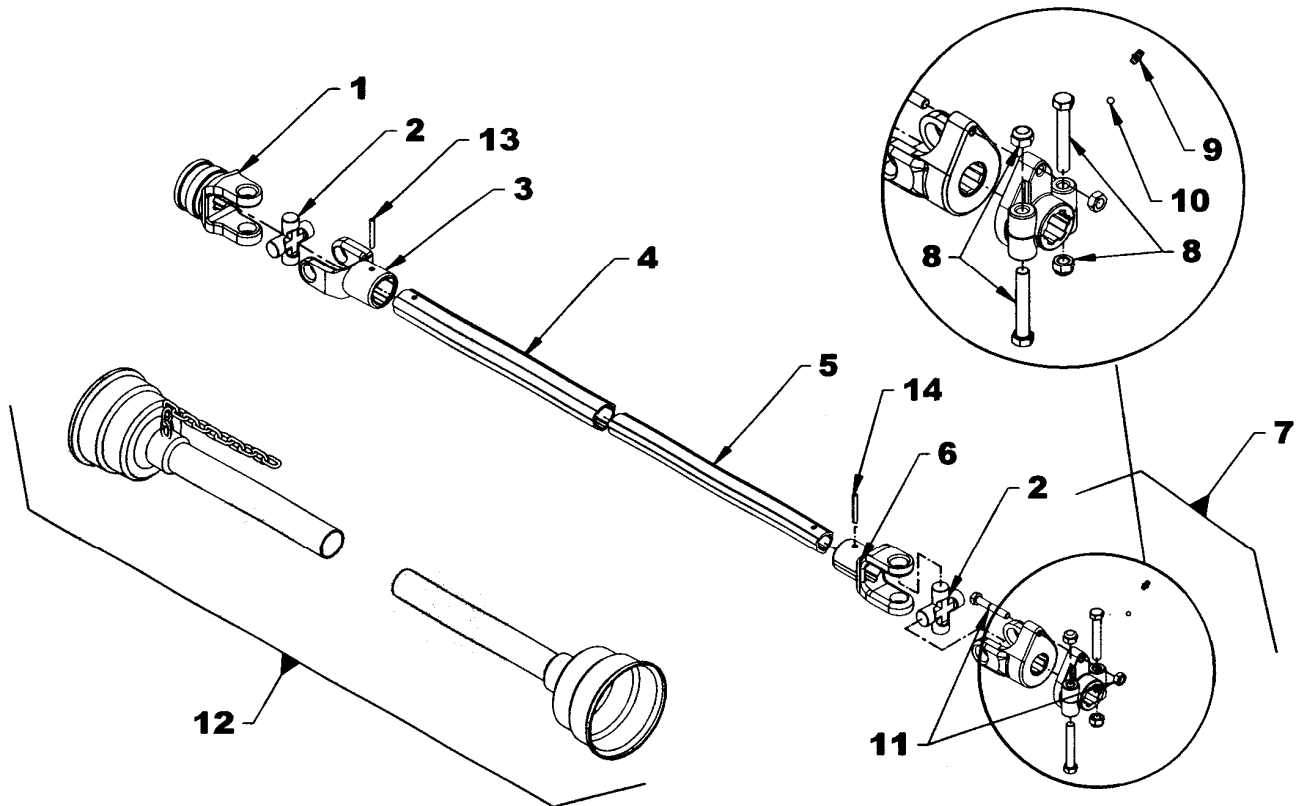

PARTS

BER0077 - MANUAL ROTATION

REF.	DESCRIPTION	QTY	PART #
1	Rotation handle	1	667425
2	Rotation tube	1	660188
3	Rotation yoke	1	659595
4	Universal block	1	658193
5	Rotation worm	1	665953
6	Rotation worm support	1	665952
7	Spring pin 1/4" x 1 1/4"	2	1600015
8	Hairpin 4mm x 80mm, PTD	1	1800002
9	Plastic handle	1	656797
10	Bushing 1 5/16" lg	2	657335
11	Hex. nut 1/4"NC, PTD	3	0900058
12	Allen socket head capscrew 10-24NC x 1" gr. 5	1	0800009
13	Nylon insert locknut 10-24 NC, PTD	1	1000002
14	Handle support	1	660187
15	Handle support bracket	1	660269
16	Hex. bolt 3/8"NC x 1 1/4" gr. 5, PTD	2	0100039
17	Hex. nut 3/8"NC PTD	2	0900003
18	Lockwasher 3/8", PTD	2	1200004
19	Setscrew 3/8"NC x 1/2", square head	1	0600006
20	Plastic Grommet	1	657390
21	Bracket	1	660388
22	Hex. bolt 3/4"NC x 1 1/2" gr. 5, PTD	1	0100115
23	Lockwasher 3/4", PTD	1	1200008
24	Hex. nut 3/4"NC, PTD	1	0900008
25	Rotation tube support	1	665951
26	Hex. bolt 1/4"NC x 3/4" gr. 5, PTD	3	0100003
27	Lockwasher 1/4", PTD	3	1200002
For the Chute Installation			
28	Spacer for retaining plate 1/16" th	4	666191

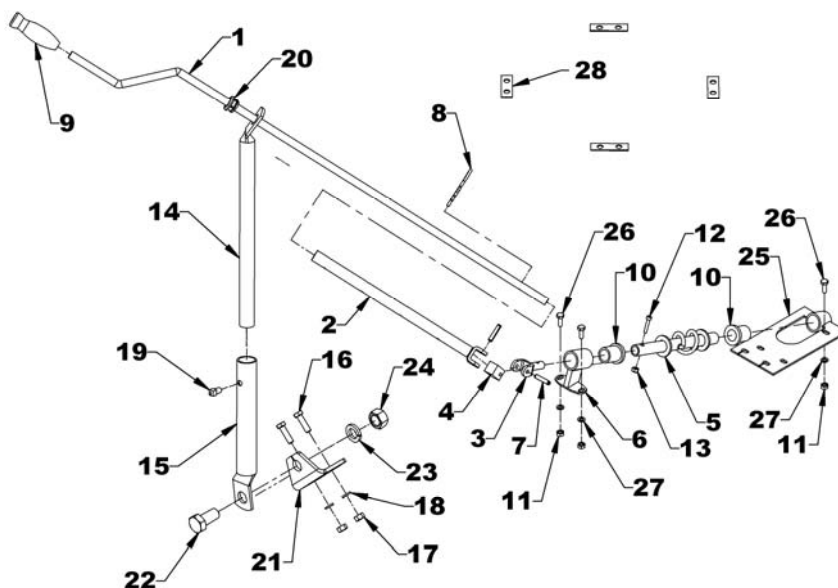

PARTS

BER0078 - HYDRAULIC ROTATION

REF.	DESCRIPTION	QTY	PART #
1	Hydraulic motor 50cc	1	3910092
	- Seal Kit	1	3910093
2	Key 1/4" x 1" woodruff (incl. in 3910092)	1	659191
3	Motor gear	1	669705
4	Flow restrictor 0.052"	2	664362
5	Rubber hose 1/4" x 75"lg.	2	666583
6	Reducer 1/4"NPT female x 1/2" NPT male	2	0100040
7	Male quick coupler	2	1000006
8	Dust cap	2	2100009
9	Flat washer 1/4" (5/16" hole) PTD	1	1400002
10	Lockwasher 1/4" PTD	3	1200002
11	Gear shield	1	669715
12	Bolt hex. 1/4"NC x 3/4" PTD	3	0100003
13	Bolt hex. 3/8"NC x 1" PTD	4	0100038
14	Lockwasher 3/8" PTD	4	1200004
15	Flat washer 3/8" (7/16" hole) PTD	4	1400004
16	Motor spacer	1	669718
17	Nut hex. 1/4"NC PTD	2	0900001

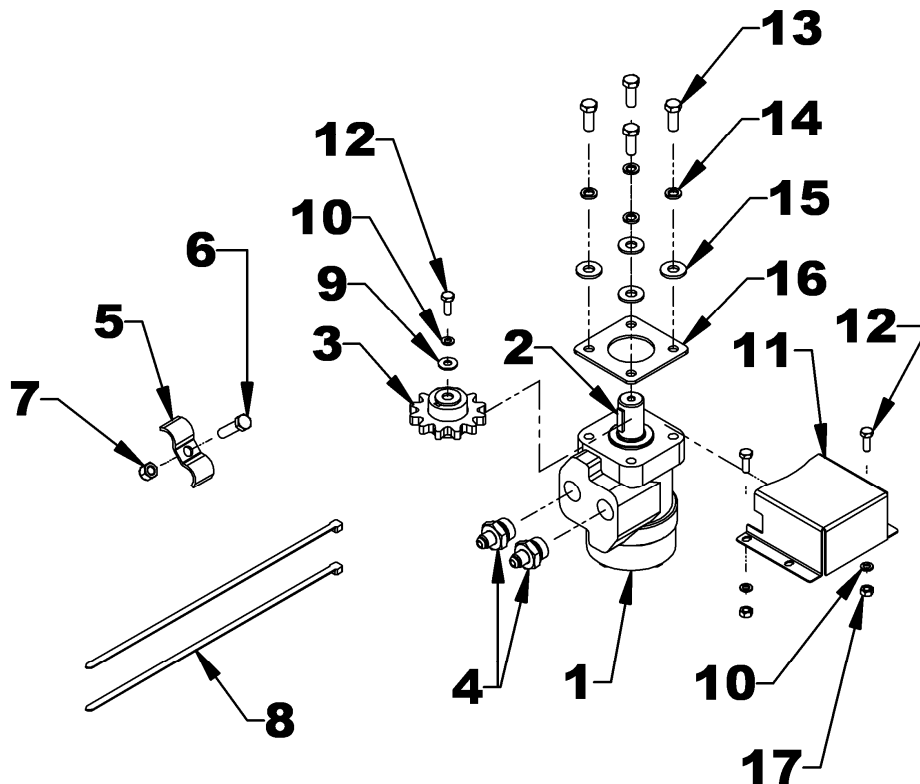

PARTS

BER0079 - HYDRAULIC DEFLECTOR

REF.	DESCRIPTION	QTY	PART #												
1	Allen flat socket head capscrews 5/16" x 3/4"	8	0700003												
2	Nylon insert locknut 5/16" NC	2	1000005												
3	Serrated flange nut 5/16" NC	8	0900036												
4	Carriage bolt 5/16" NC x 3/4" Gr.5	2	0300002												
5	Elbow 90° 3/8" NPT STM x 1/4" NPT SWF	2	654438												
6	Deflector bracket	1	660142												
7	Deflector base bracket	1	660143												
8	Cylinder & pins	1	665433												
	- Seal kit	1	665434												
9	Cotter pin 3/16" x 1 1/2"	4	1500013												
10	Pin 3/4" x 2 1/2"	2	665235												
11	Hose support	1	669031												
12	Hose clamp	1	666583	13	Bolt hex. 3/8" NC x 1 1/2" PTD	3	0100040	14	Nylon insert locknut 3/8" NC PTD	3	1000006	15	Nylon tie wrap 1/4" x 15" lg.	2	2100009
13	Bolt hex. 3/8" NC x 1 1/2" PTD	3	0100040												
14	Nylon insert locknut 3/8" NC PTD	3	1000006												
15	Nylon tie wrap 1/4" x 15" lg.	2	2100009												

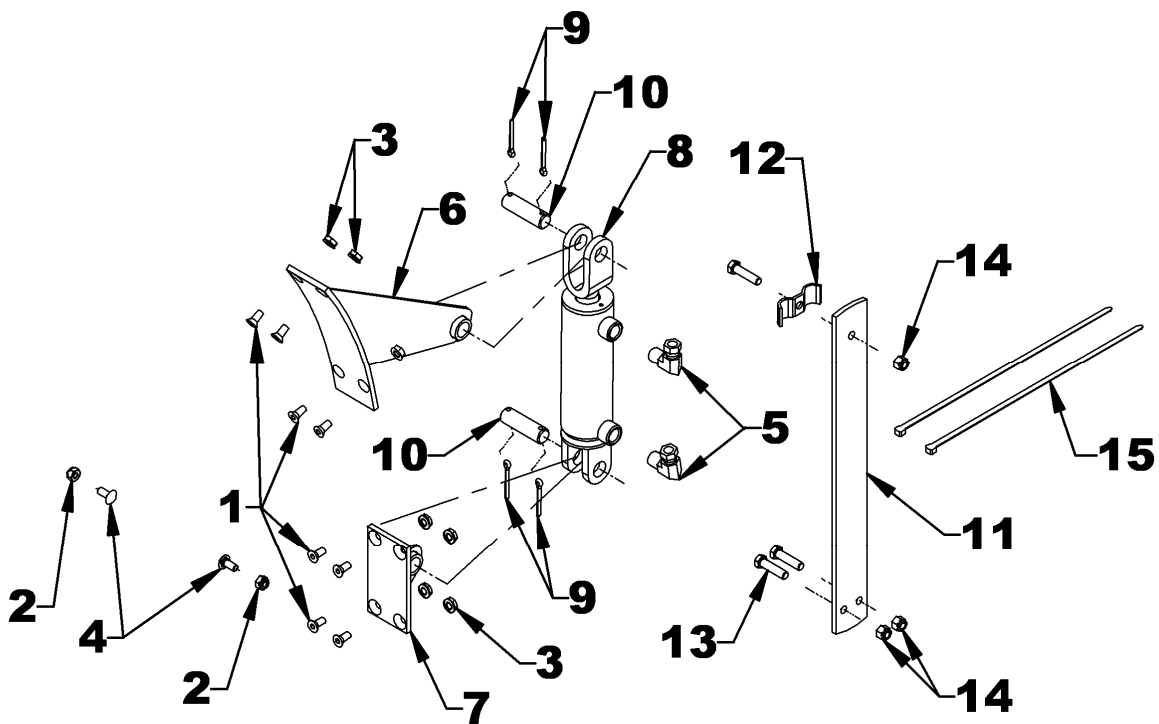

PARTS

8151- ELECTRIC DEFLECTOR

REF.	DESCRIPTION	QTY	PART #
1	Actuator	1	662983
2	Switchbox	1	666048
3	Switch	1	663383
4	Rubber cap	1	658666
5	Plastic cap	1	662530
6	Clevis – rod	1	666049
7	Clevis – base	1	666050
8	Pin 1"	2	666057
9	Ground wire 72" (black)	1	666054
10	Tap connector	1	656665
11	Fuse wire 72" (red)	1	666055
12	Actuator wire assembly	1	666056
13	Spring pin 3/16" x 1 3/4", black	2	1600009
14	Hairpin 4mm x 80mm, PTD	2	1800002
15	Self-drilling screw #10 x 1/2"	4	3200011
16	Bolt hex. 1/2"NC x 2 1/2", PTD	2	0100076
17	Nylon insert locknut 1/2"NC, PTD	2	1000011
18	Loom 3/8" x 420"	1	666053
19	Nylon insert locknut 5/16"NC, PTD	2	1000005
20	Nylon insert locknut 8" lg x 4 mm	5	2100003
21	Deflector bracket	1	669826
22	Base bracket	1	669825
23	Allen setscrew, flat head 5/16"NC x 3/4"	8	0700003
24	Serrated flange nut 5/16"NC, PTD	8	0900036
25	Carriage bolt 5/16"NC x 3/4" PTD	2	0300002

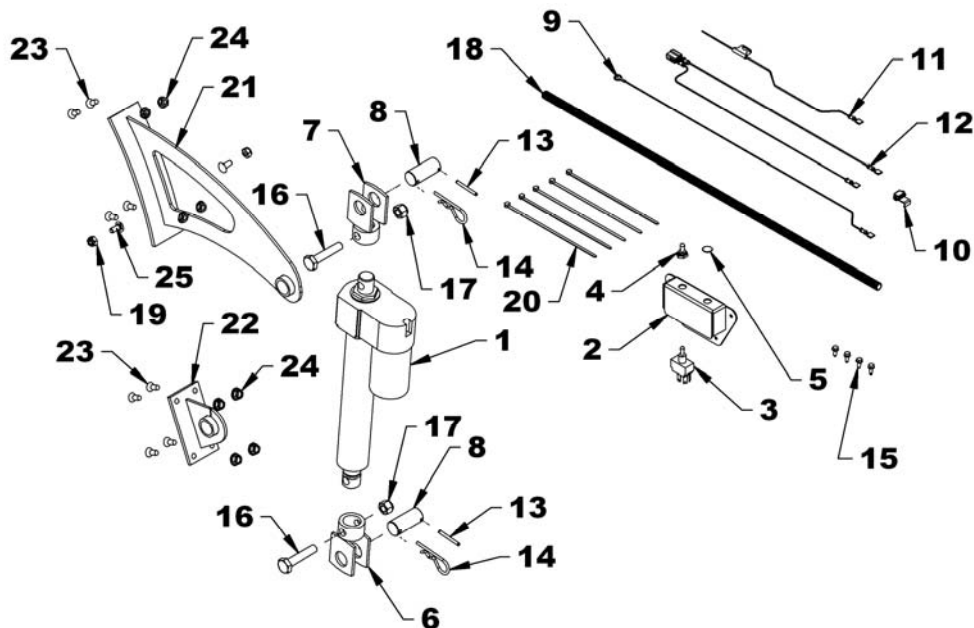







TORQUE SPECIFICATION TABLE

























GENERAL SPECIFICATION TABLE

Use the following torques when special torques are not given

NOTE: These values apply to fasteners as received from supplier, dry, or when lubricated with normal engine oil. They do not apply if special graphited or moly sidulphide greases or other extreme pressure lubricants are used. This applies to both UNF and UNC threads.

SEE Grade No.		2				5				8			
BOLT HEAD IDENTIFICATION MARKS AS PER GRADE NOTE: MANUFACTURING MARKS WILL VARY.						  				  			
BOLT SIZES		Torque				Torque				Torque			
Inches	Millimeters	Pounds-Foot		Newtons-Meter		Pounds-Foot		Newtons-Meter		Pounds-Foot		Newtons-Meter	
		MIN.	MAX.	MIN.	MAX.	MIN.	MAX.	MIN.	MAX.	MIN.	MAX.	MIN.	MAX.
1/4	6.35	5	6	6.8	8.13	9	11.0	12.2	14.9	12	15	16.3	30.3
5/16	7.94	10	12	13.6	16.3	17	20.5	23.1	27.8	24	29	32.5	39.3
3/8	9.53	20	23	27.1	31.2	35	42.0	47.5	57.0	45	54	61.0	73.2
7/16	11.11	25	30	40.7	47.4	54	64.0	73.2	86.8	70	84	94.9	113.9
1/2	12.70	45	52	61.0	70.5	80	96.0	108.5	130.2	110	132	149.2	179.0
9/16	14.29	65	75	88.1	101.6	110	132.0	149.2	179.0	160	192	217.0	260.4
5/8	15.88	95	105	128.7	142.3	150	180	203.4	244.1	220	264	298.3	358.0
3/4	19.05	150	185	203.3	250.7	270	324	366.1	439.3	380	456	515.3	618.3
7/8	22.23	160	200	216.8	271.0	400	480	542.4	650.9	600	720	813.6	976.3
1	25.40	250	300	338.8	406.5	580	696	786.5	943.8	900	1080	1220.4	1464.5
1 1/8	25.58	-	-	-	-	800	880	1084.8	1193.3	1280	1440	1735.7	1952.6
1 1/4	31.75	-	-	-	-	1120	1240	1518.7	1681.4	1820	2000	2467.9	2712.0
1 3/8	34.93	-	-	-	-	1460	1680	1979.8	2278.1	2380	2720	3227.3	3688.3
1 1/2	38.10	-	-	-	-	1940	2200	2630.6	2983.2	3160	3560	4285.0	4827.4

METRIC BOLT TORQUE SPECIFICATIONS

Size of screw	Grade No.	Pitch mm	Coarse thread				Pitch mm	Fine Thread			
			Pounds-Foot		Newtons-Meter			Pounds-Foot		Newtons-Meter	
			MIN.	MAX.	MIN.	MAX.		MIN.	MAX.	MIN.	MAX.
M6	4T 	1.0	3.6	5.8	4.9	7.9	-	-	-	-	
	7T 		5.8	9.4	7.9	12.7	-	-	-	-	
	8T 		7.2	10	9.8	13.6	-	-	-	-	
M8	4T 	1.25	7.2	14	9.8	19.0	12	17	16.3	23.0	
	7T 		17	22	23	29.8	19	27	25.7	36.6	
	8T 		20	26	27.1	35.2	22	31	29.8	42	
M10	4T 	1.5	20	25	27.1	33.9	20	29	27.1	39.3	
	7T 		34	40	46.1	54.2	35	47	47.4	63.7	
	8T 		38	46	51.5	62.3	40	52	54.2	70.5	
M12	4T 	1.75	28	34	37.9	46.1	31	41	42	55.6	
	7T 		51	59	69.1	79.9	56	68	75.9	92.1	
	8T 		57	66	77.2	89.4	62	75	84	101.6	
M14	4T 	2.0	49	56	66.4	75.9	52	64	70.5	86.7	
	7T 		81	93	109.8	126	90	106	122	143.6	
	8T 		96	109	130.1	147.7	107	124	145	168	
M16	4T 	2.0	67	77	90.8	104.3	69	83	93.5	112.5	
	7T 		116	130	157.2	176.2	120	138	162.6	187	
	8T 		129	145	174.8	196.5	140	158	189.7	214.1	
M18	4T 	2.0	88	100	119.2	136	100	117	136	158.5	
	7T 		150	168	203.3	227.6	177	199	239.8	269.6	
	8T 		175	194	237.1	262.9	202	231	273.7	313	
M20	4T 	2.5	108	130	146.3	176.2	132	150	178.9	203.3	
	7T 		186	205	252	277.8	206	242	279.1	327.9	
	8T 		213	249	288.6	337.4	246	289	333.3	391.6	

Manufactured by:



RADTECH

Division of RAD Technologies Inc.

2835, Chemin de l'Aéroport

Thetford Mines, Québec, Canada, G6G 5R7

Tel.: (418) 338-4499 - Fax: (418) 338-6090

e-mail : radtech@radinter.com

Internet : www.radinter.com

Printed in Canada