

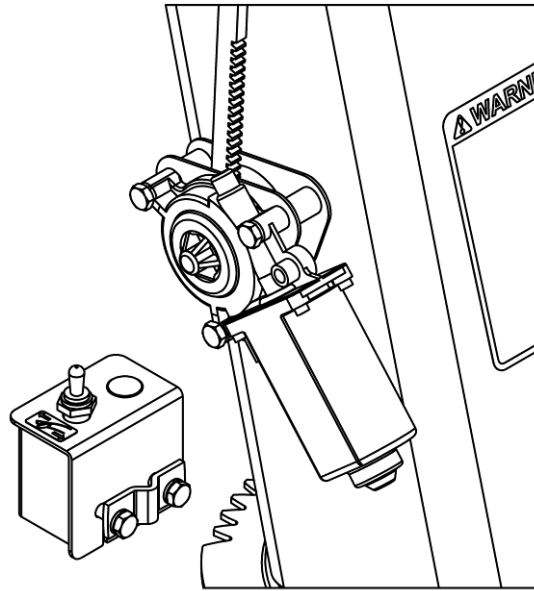

**RADTECH**  
INNOVATION



# ***INSTRUCTION'S AND PARTS MANUAL***

***Electric deflector***

**BER0119**

***For John Deere Tractor***





# INTRODUCTION

## TO THE PURCHASER

All products are designed to give safe, dependable service if they are operated and maintained according to instructions. **Read and understand this manual before operation and keep it in your files for further reference.**

This manual has been prepared to assist the owner and operators in the safe operation and suitable maintenance of the equipment. The information is applicable to products at the time of manufacture and does not include modifications made afterwards.

Read and understand this operator's manual before attempting to put equipment into service. Familiarize yourself with the operating instructions **AND ALL THE SAFETY RECOMMENDATIONS** contained in this manual and those labeled on the equipment and on the machine. Follow the safety recommendations and make sure that those with whom you work follow them.

## TO THE DEALER

Give this manual to the owner upon delivery of the equipment.

## TO THE PURCHASER AND THE DEALER

### Illustrations

The illustrations may not necessarily reproduce the full detail and the exact shape of the parts or depict the actual models but are for reference only.

### Direction Reference

All references to right and left, forward or rearward are from the operator's seat.

*To assist your dealer in handling your needs, please record hereafter the model number and serial number of your equipment and machine. It is also advisable to supply them to your insurance company. It will be helpful in the event that equipment or machine is lost or stolen.*

MODEL: \_\_\_\_\_

DATE OF PURCHASE: \_\_\_\_\_

DEALER NAME: \_\_\_\_\_

DEALER TELEPHONE NUMBER: \_\_\_\_\_

# INTRODUCTION

All products are designed to give safe, dependable service if they are operated and maintained according to instructions. **Read and understand this manual before operation**. It is the owner's responsibility to be certain anyone operating this product reads this manual, and all other applicable manuals, to become familiar with this equipment and all safety precautions. Failure to do so could result in serious personal injury or equipment damage. If you have any questions, consult your dealer.

---

## SAFETY FIRST

This symbol, the industry's "Safety Alert Symbol", is used throughout this manual and on labels on the machine itself to warn of the possibility of personal injury. Read these instructions carefully. It is essential that you read the instructions and safety regulations before you attempt to assemble or use this unit.

 **DANGER :** Indicates an imminently hazardous situation which, if not avoided, will result in death or serious injury.

 **WARNING :** Indicates a potentially hazardous situation which, if not avoided, could result in death or serious injury.

 **CAUTION :** Indicates a potentially hazardous situation which, if not avoided, may result in minor or moderate injury.

**IMPORTANT :** Indicates that equipment or property damage could result if instructions are not followed.

**NOTE :** Gives helpful information.

# TABLE OF CONTENTS

INTRODUCTION .....	1
TABLE OF CONTENTS.....	3
SAFETY INFORMATION .....	4
GENERAL SAFETY INFORMATION – Pictograms .....	6
ESTIMATED ASSEMBLY TIME .....	8
ASSEMBLY .....	9
Installation of the Electric Deflector.....	10
Installation of the Harness of the Electric Deflector #4000174 .....	11
Electric Diagram of the Snowblower Deflector .....	12
Installation of the Harness with Fuse #4000173.....	13
Installation of the Main Harness #4000172 .....	14
lubrication .....	18
PARTS .....	19
Chute Electric Deflector .....	19
WARRANTY .....	21
TORQUE SPECIFICATION TABLE .....	22



# SAFETY INFORMATION

## **Before Operation**

1. Park the machine/implement on level ground, set the parking brake, lower the implement to the ground, place all control levers in neutral, shut off the engine and remove the ignition key and allow the rotating parts to stop BEFORE making any implement adjustments.
2. Do not put hands or feet under implement and frame.
3. Do not operate the machine/implement that is defective or has missing parts. Make sure that all recommended maintenance procedures are completed before operating the unit.
4. Keep the machine/implement clean. Snow, dirt or ice build-up can lead to malfunction or personal injury from thawing and refreezing in garage.
5. Do not modify or alter this equipment or any of its components, or any equipment function without first consulting your dealer. The manufacturer will not claim responsibility for fitment of unapproved parts and/or accessories and any damages as a result of their use.
6. Verify that all machine/implement safety protective devices are in place. Shields, guards and covers must be correctly installed at all times. When necessary to remove these for servicing, cleaning, or repair work, they must be reinstalled immediately.
7. Always make sure all implement components are properly installed and securely fastened.
8. Check for moving parts excessive wear regularly. ALWAYS USE GENUINE PARTS WHEN REPLACEMENT PARTS ARE REQUIRED.
9. Prior to operation, clear work area and mark all curbs, pipes, etc. that cannot be moved.
10. Inspect the machine/implement after striking any foreign object to assure that all machine/implement parts are safe and secure and not damaged.
11. Handle fuel with care, as it is highly flammable. Use approved fuel container.
12. Never add fuel to a running engine or a hot engine.
13. Fill fuel tank outdoors with extreme care. Never fill fuel tank indoors. Replace fuel cap securely and wipe up spilled fuel.
14. Check all machine controls regularly and adjust where necessary. Make sure that the brakes are evenly adjusted. Periodically check all nuts and bolts for tightness, especially wheel hub and rim nuts.
15. Make sure the machine is counterweighted and has tire chains for better traction and stability as recommended by your dealer. Weights provide the necessary balance to improve stability, traction and steering. Use only those recommended by your dealer













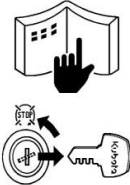

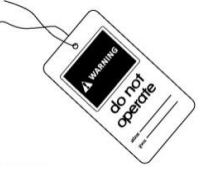
## SAFETY INFORMATION

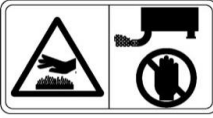
### During Operation

1. Never allow anyone to operate the machine and implement until they have read the manuals completely and are thoroughly familiar with their basic operation. Lack of operating knowledge can lead to accidents.
2. Do not allow anyone to ride on the machine/implement at any time. The only person allowed is the operator who MUST sit in the driver's seat.
3. Never allow anyone near the work area.
4. Never operate the implement without safety protective devices in place. All machine/implement shields, guards and covers must be correctly installed at all times.
5. Park the machine/implement on level ground, place the transmission in neutral, set the parking brake, disengage the driving system, lower the equipment to the ground, place all levers including auxiliary control levers in neutral, shut off the engine and remove the ignition key BEFORE LEAVING THE MACHINE.
6. Always drive the machine at speeds compatible with safety, especially when operating over rough ground, crossing ditches, slippery surface or when turning.
7. Use extra caution when backing up.
8. Operate only with good visibility and during daylight hours, or when the area is well lit with bright artificial light.
9. Exercise extreme caution when operating on or crossing a gravel drive, walks, or roads. Stay alert for hidden hazards or traffic.
10. Never park the machine on a steep slope. Do not attempt to operate on steep slopes. If operating on slopes is necessary, exercise extreme caution when changing direction.





# GENERAL SAFETY INFORMATION

	<p><b>BEFORE YOU START SERVICE</b></p> <ul style="list-style-type: none"> <li>• Read all instructions and safety instructions in this manual and on your machine safety decals.</li> <li>• Clean the work area and machine.</li> <li>• Park the machine on a stable and level ground, and set the parking brake.</li> <li>• Lower the implement to the ground.</li> <li>• Stop the engine, then remove the key.</li> <li>• Disconnect the battery negative cable.</li> <li>• Hang a "DO NOT OPERATE" tag in the operator station.</li> </ul>		<p><b>No Smoking or Open Flames while Fueling</b></p> <ul style="list-style-type: none"> <li>• Fuel is extremely flammable and dangerous. Never smoke near fuel. If fuel is spilled on the machine, its engine, or electrical parts, it may cause a fire. If fuel is spilled, wipe it all up immediately.</li> <li>• Never smoke while filling the machine with fuel. And always tighten the fuel cap securely and wipe up any spilled fuel.</li> </ul>
	<ul style="list-style-type: none"> <li>• When performing maintenance on the equipment, hang the DO NOT OPERATE sign where it will be obvious from and around the driver's seat.</li> <li>• When performing maintenance or repairs, always lower attachments to the ground, stop the engine and secure the tracks with blocks.</li> <li>• When performing maintenance on the equipment, always disconnect the negative battery cable.</li> <li>• Before using tools, make sure you understand how to use them correctly and use tools in good condition and of the right size for the job.</li> </ul>		<ul style="list-style-type: none"> <li>• Before getting on/off of the machine, clean off around the steps so there is no mud on them. Always give yourself 3-point support when getting on/off the machine.</li> </ul> <p><b>CAUTION</b></p> <ul style="list-style-type: none"> <li>• 3-point support means using both legs and one hand or both hands and one leg as you climb up/down.</li> </ul>
	<p><b>START SAFELY</b></p> <ul style="list-style-type: none"> <li>• Do not do the procedures below when you start the engine. <ul style="list-style-type: none"> <li>– short across starter terminals</li> <li>– bypass the safety start switch</li> </ul> </li> <li>• Do not alter or remove any part of machine safety system.</li> <li>• Before you start the engine, make sure that all shift levers are in neutral positions or in disengaged positions.</li> <li>• Do not start the engine when you stay on the ground. Start the engine only from operator's seat.</li> </ul>		<ul style="list-style-type: none"> <li>• Do not remove the radiator cap when the engine operates, or immediately after it stops. If not, hot water can spout out from the radiator. Only remove the radiator cap when it is at a sufficiently low temperature to touch with bare hands. Slowly loosen the cap to release the pressure before you remove it fully.</li> </ul>
	<p><b>Starting the Machine Safely</b></p> <ul style="list-style-type: none"> <li>• Before starting the engine, always sit in the driver's seat and make sure the area is safe and clear.</li> <li>• As it is dangerous, never start the engine from anywhere but the driver's seat.</li> <li>• Always check and make sure control lever(s) are not engaged before starting the engine.</li> <li>• Never start the engine by hot-wiring the starter circuit. This is not only dangerous, but may damage the machine.</li> </ul>		<ul style="list-style-type: none"> <li>• The engine, muffler, radiator, hydraulic line, etc., have parts that remain very hot even after the engine has been stopped. Be sure to avoid these parts, as touching them can result in burns. Radiator coolant, hydraulic fluid and oil also remain hot. Therefore, do not attempt to remove caps and plugs, etc., before these fluids have sufficiently cooled.</li> <li>• Make sure the coolant temperature has dropped sufficiently before opening the radiator cap. Also, since the inside of the radiator is pressurized, when removing the cap, first loosen it to release the pressure before removing the cap completely.</li> </ul>
	<ul style="list-style-type: none"> <li>• Wear clothes appropriate for working on equipment. Do not wear loose-fitting clothes as they may catch on the machine controls.</li> <li>• When working on the equipment, use all safety gear, such as a helmet, safety glasses and shoes, that are required by law or regulation.</li> <li>• Never perform maintenance while drowsy or under the influence of alcohol or drugs.</li> </ul>		<ul style="list-style-type: none"> <li>• Grease is under high pressure inside the hydraulic cylinder. It is very dangerous to loosen a grease nipple quickly as it may shoot off. Always loosen grease nipples slowly.</li> <li>• And never face a grease nipple while loosening it.</li> </ul>
	<p><b>Be Ready for an Emergency</b></p> <ul style="list-style-type: none"> <li>• Keep a first-aid kit and fire extinguisher close at hand so you can use it when needed.</li> <li>• Keep emergency contact information for doctors, hospitals and ERs handy.</li> </ul>		<p><b>PREVENT A FIRE</b></p> <ul style="list-style-type: none"> <li>• Fuel is very flammable and explosive under some conditions. Do not smoke or let flames or sparks in your work area.</li> <li>• To prevent sparks from an accidental short circuit, always disconnect the battery negative cable first and connect it last.</li> <li>• The battery gas can cause an explosion. Keep the sparks and open flame away from the top of battery, especially when you charge the battery.</li> <li>• Make sure that you do not spill fuel on the engine.</li> </ul>
	<p><b>KEEP A GOOD AIRFLOW IN THE WORK AREA</b></p> <ul style="list-style-type: none"> <li>• If the engine is in operation, make sure that the area has good airflow. Do not operate the engine in a closed area. The exhaust gas contains poisonous carbon monoxide.</li> </ul>		<p><b>Dispose of Waste Fluids Properly</b></p> <ul style="list-style-type: none"> <li>• Never dispose of waste fluids on the ground, in the gutter, a river, pond or lake. Always dispose of hazardous substances like waste oil, coolant and electrolytic fluid in accordance with the relevant environmental protection regulations.</li> <li>• Keep the safety plates clean so they can be read. If a safety plate is damaged and comes off or becomes illegible, put a plate with the same warnings back in its place.</li> </ul>

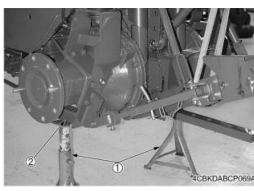

# GENERAL SAFETY INFORMATION

	<ul style="list-style-type: none"><li>• The pressure in the hydraulic circuit stays at pressure even after the engine stops. Before removing parts, such as hydraulic devices from the machine, first release the pressure. Please note that when releasing residual pressure, the machine itself and/or implements may move without warning, so be very careful when releasing the pressure.</li><li>• Oil gushing out under pressure is extremely dangerous as it may pierce your skin or your eyes. Similarly, oil leaking out of pinholes is not visible. So when checking for oil leaks, always wear safety glasses and gloves and use a piece of cardboard or a wood block to shield yourself from oil.</li></ul>		<ul style="list-style-type: none"><li>• When you need to access the underside of the machine for maintenance purposes, but sure to support the machine with a safety stand. Getting under the machine while supporting the machine by machine's own hydraulic cylinder or using a hydraulic jack can be extremely dangerous in the event of a hydraulic fluid leakage or similar mishap.</li></ul> <p>(1) Safety stand (2) Secure point for safety stand</p>
	<ul style="list-style-type: none"><li>• Do not open a fuel system under high pressure. The fluid under high pressure that stays in fuel lines can cause serious injury. Do not disconnect or repair the fuel lines, sensors, or any other components between the fuel pump and injectors on engines with a common rail fuel system under high pressure.</li><li>• Put on an applicable ear protective device (earmuffs or earplugs) to prevent injury against loud noises.</li><li>• Be careful about electric shock. The engine generates a high voltage of more than DC100 V in the ECU and is applied to the injector.</li></ul>		<ul style="list-style-type: none"><li>• Whenever it is necessary to open the engine covers or hood in order to service the machine, always prop them open.</li><li>• If it is absolutely necessary to run the engine while working on the machine, make sure you are clear of all rotating or moving parts. Also take care not to leave anything, such as tools or rags, near any moving parts.</li></ul>
	<ul style="list-style-type: none"><li>• Engage the loader control valve lock to prevent accidental actuation when the implement is not in use or during transport. Do not utilize the valve lock for machine maintenance or repair.</li><li>• Do not perform machine maintenance with loader in the air. If possible, follow loader instructions to remove loader before performing maintenance.</li><li>• If the machine has a backhoe, engage swing and boom locks.</li></ul>		

# ESTIMATED ASSEMBLY TIME

Refer to the following table for the estimated assembly time to open the package and assemble the equipment and options.

	<b>Electric Deflector BER0119</b>
Estimated installation initial time	45 - 60 min
2nd installation time (on the tractor)	1 - 2 min

The assembly times of the table are only a reference under normal conditions according to the following assumptions:

1. The assembly is done by a competent person who is familiar with the equipment.
2. The following tools and materials are prepared:
  - Wrench set (flat wrenches)
  - Ratchet & socket set
  - Cutting pliers
  - Security gloves

# ASSEMBLY

**⚠ WARNING:** To avoid serious personal injury or death: Read and understand the SAFETY PRECAUTIONS on previous pages before installation and operation. Perform all assembly with unit properly blocked and supported. **TORQUE ALL THE BOLTS ACCORDING TO THE TORQUE SPECIFICATION TABLE ENCLOSED AT THE END OF THE INSTRUCTION SHEET.**

- 1. Figure 1:** If the chute is equipped with knobs. Remove the two manual knobs (item 1) on each side of the deflector and replace them with washers (item 2) and nylon insert locknut (item 3). Leave a small gap (about 1/32") between the side of the deflector and the chute. Repeat the operation on the other side if the chute is equipped of two knobs.
- 2. Figure 2:** Drill a hole with a  $\varnothing 9/32$ " drill on the left side of deflector in the location defined in the figure.

**NOTE:** The deflector must move freely.

- 3. Figure 2:** Mark the two holes  $\varnothing 9/32$ " on the left side of the chute in the location defined in the figure, then use the guide plate to mark the third hole.
- 4. Figure 3:** Position the guide plate (item 5) on the side of the chute to confirm the marks of the holes. Ensure that the marks correspond to the holes of the guide plate and drill the three  $\varnothing 9/32$ " holes.

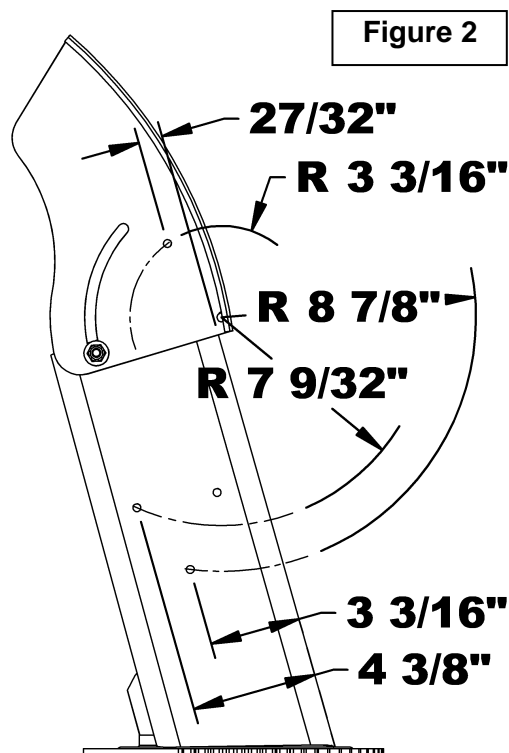
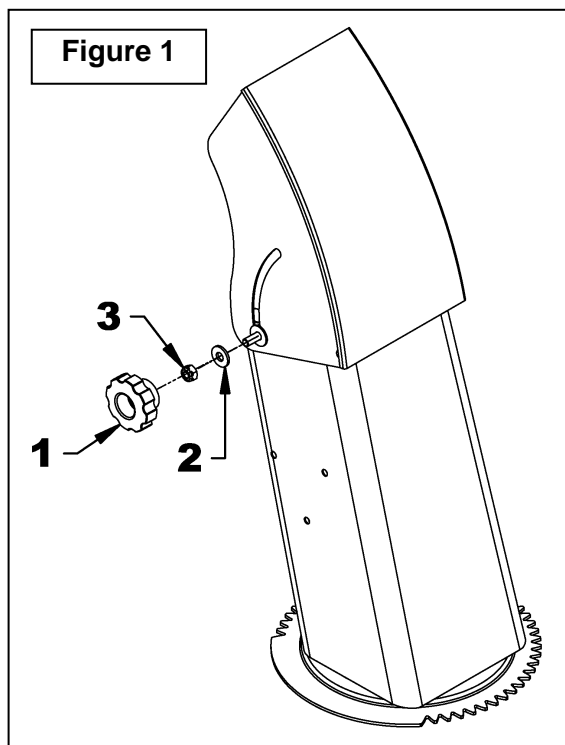

# ASSEMBLY

## Installation of the Electric Deflector (Figure 3)

1. **Figure 3:** Apply a light coat of the recommended grease on the teeth of the rack (item 1) and insert it inside the guide rack (item 2) as shown on the left figure.
2. **Figure 3:** Then attach the guide plate (item 5A), the guide rack (item 2), the three spacer rings (item 6), the second guide plate (item 5B) and the electric motor (item 4) on the chute side using the three 1/4"NC x 2" lg hex bolts (item 3), and 1/4"NC nylon insert locknuts (item 8)
3. **Figure 3:** Apply a light coat of the recommended grease inside the hole of the rack (item 1), insert the 3/8" x 19/32" bushing (item 10) and place two 7/16" nylon flat washers (item 9A) between the deflector and the rack, to allow a small clearance. Install the remaining nylon washer (item 9B) on the other side of the rack.

**IMPORTANT : The rack should not be forced by the nylon washers (item 9).**

4. **Figure 3:** Secure with the 1/4"NC x 1 1/4" lg. hex bolt (item 11), 1/4" (5/16" hole) flat washer (item 12), 3/8 "x 19/32" lg pivot bushing (item 10), nylon washers (item 9A) and 1/4"NC nylon insert locknut (item 8), in the order shown in figure.

N°	PARTS FIGURE 1	QTY
1	Rack PTD	1
2	Guide rack	1
3	Bolt hex 1/4"NC x 2" PTD	3
4	Electric Motor	1
5	Guide plate PTD	1
6	Spacer 3/8" x .721" PTD	3
7	Chute	1
8	Nylon insert locknut 1/4"NC PTD	4
9	Nylon flat washer 716"	3
10	Pivot bushing 3/8" x 19/32" PTD	1
11	Bolt hex 1/4"NC x 1 1/4" PTD	1
12	Flat washer 1/4" PTD	1

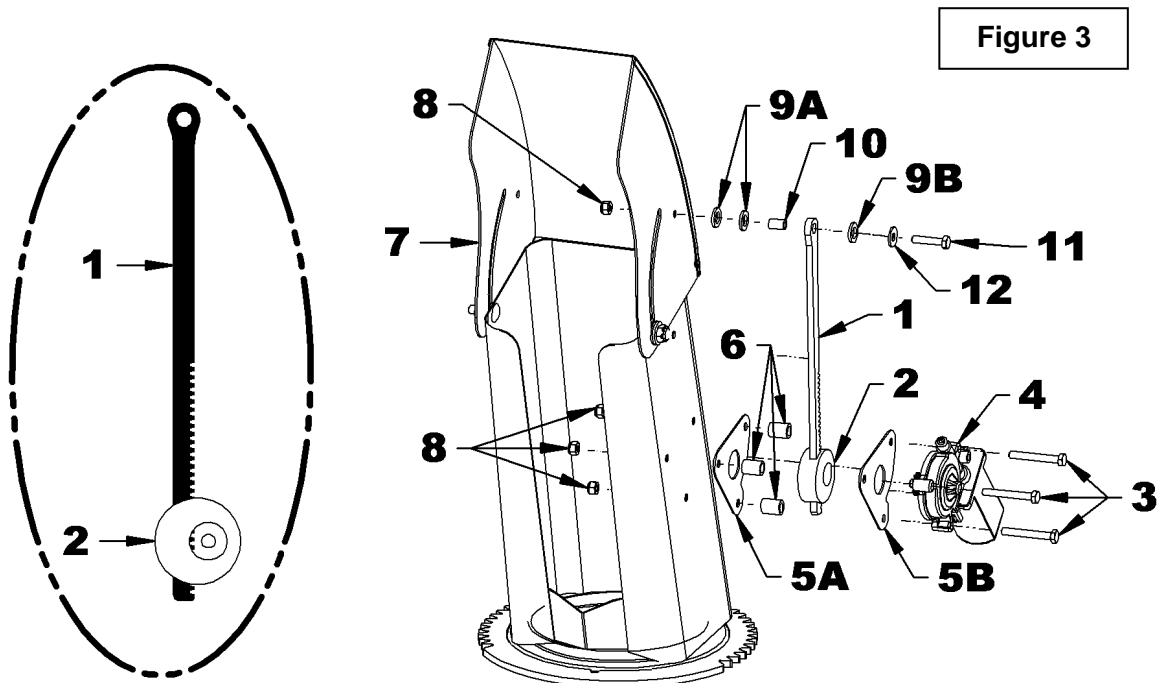

Figure 3

# ASSEMBLY

## Installation of the Harness of the Electric Deflector #4000174 (Figure 4)

1. **Figure 4:** Turn the chute completely to the right and secure the female connector of the deflector electric harness to the electric motor. Attach and fix the motor sheath (item 1) with a 1/4" x 15" tie wrap (item 2) as shown in the figure.

**IMPORTANT** : Be sure not to over tighten the electrical harness with the nylon tie wrap.

2. Next cut the excess of the nylon fastener approximately 1/8" from the tie.
3. **Figure 4:** Attach the electrical harness (item 1) to the snowblower with a nylon tie wrap (item 3).

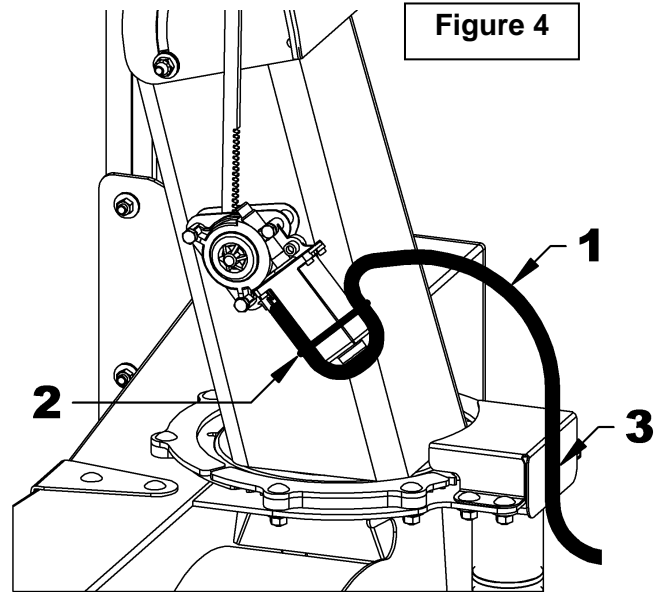

# ASSEMBLY

## Electric Diagram of the Snowblower Deflector

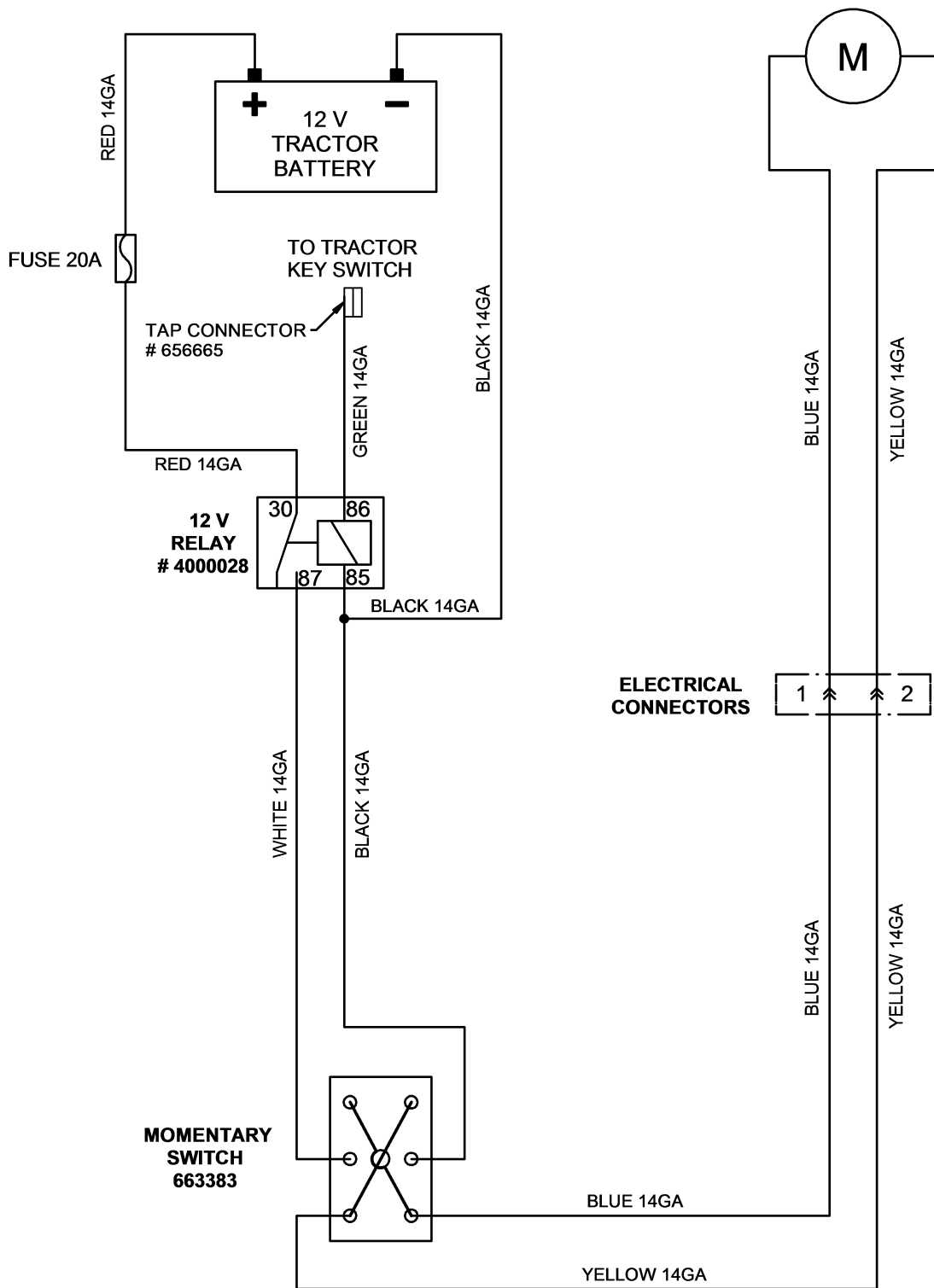

# ASSEMBLY

## Installation of the Harness with Fuse #4000173 (Figures 5-5a-5b)

1. Group together all items listed in the figures 8 Table.
2. **Figure 5:** Remove temporarily the fuse (item 7) from the harness fuse holder (item 5).
3. **Figure 5:** Attach the fuse wire (item 5a) to the positive (+) terminal of the tractor battery.
4. **Figure 5:** Attach the connector of the **green wire to the 86 terminal of the relay** (item 1).
5. **Figure 5:** Attach the connector of the **red wire to the 30 terminal of the relay** (item 1).
6. **Figure 5:** Attach the relay (item 1) to the radiator plate of the tractor using the 8-32 x 3/4" machine screw round socket head, the #8 (Ø3/16" int.) flat washer and the #8-32 nylon insert locknut (items 2-3-4).
7. **Figures 5, 5a, 5b:** Place the green wire (item 5b) at the place indicated in the figure and follow the alternator wire (item 9) which runs on the left side of the tractor.
8. **Figures 5a, 5b:** Attach the green wire (item 5b) to the accessory red wire of the tractor (item 10) using the tap connector (item 6).
9. **Figure 5b:** Secure the green wire (item 5b) to the alternator wire with a 4.8mm x 8" lg nylon tie wrap (item 8).

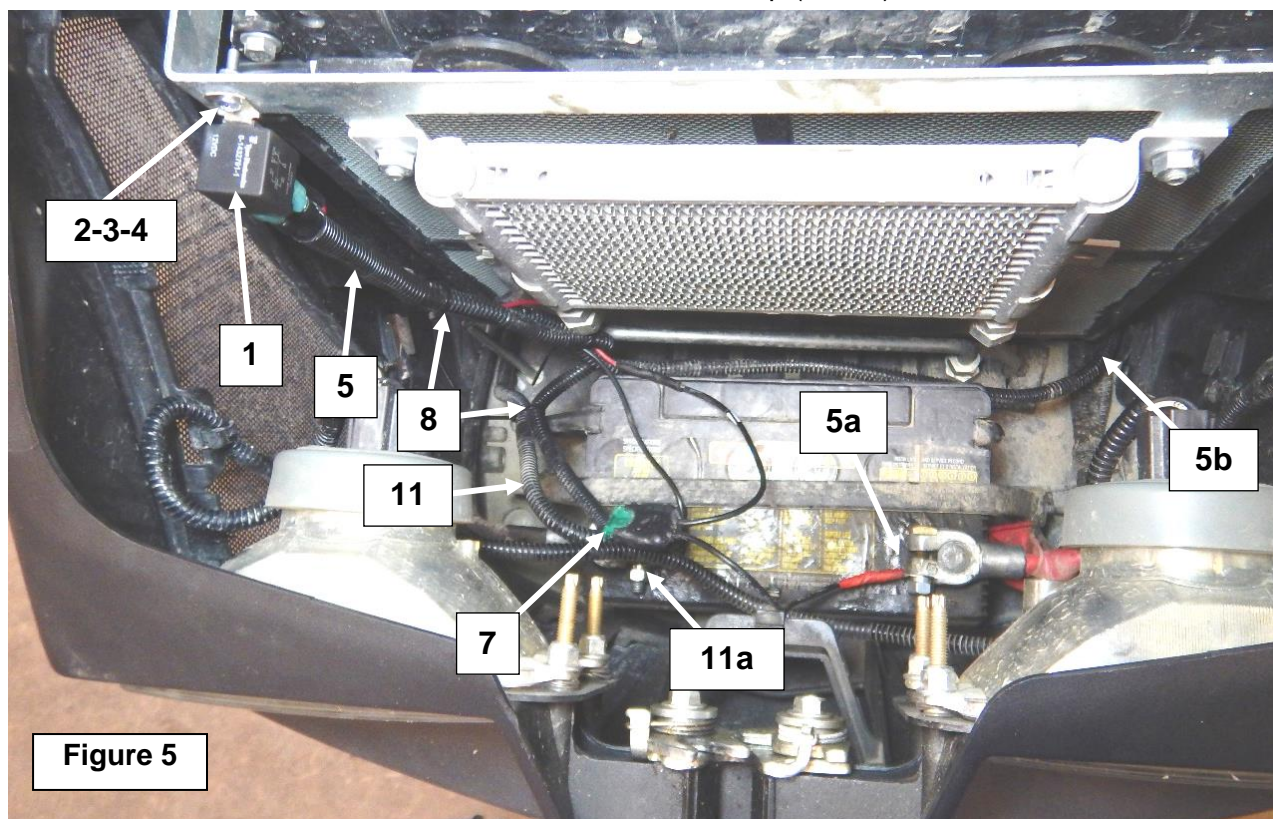

**Figure 5**

N°	PARTS FIGURES 5-5a-5b	QTY
1	RELAY 12 VOLT	1
2	MACHINE SCREW #8-32 x 3/4" LG, ROUND SOCKET HEAD PTD	1
3	FLAT WASHER #8 (Ø3/16" INT) PTD	1
4	NYLON INSERT LOCKNUT #8-32 PTD	1
5	ELECTRIC HARNESS WITH FUSE #4000173 (42 1/2" LG)	1
6	TAP CONNECTOR	1
7	FUSE 20A (included with the harness)	1
8	NYLON TIE WRAP 4.8mm x 8" LG.	3
9	TRACTOR ALTERNATOR WIRE	---
10	TRACTOR RED ACCESSORY WIRE	---
11	MAIN ELECTRIC HARNESS #4000172 (93 1/2" LG.)	1

# ASSEMBLY

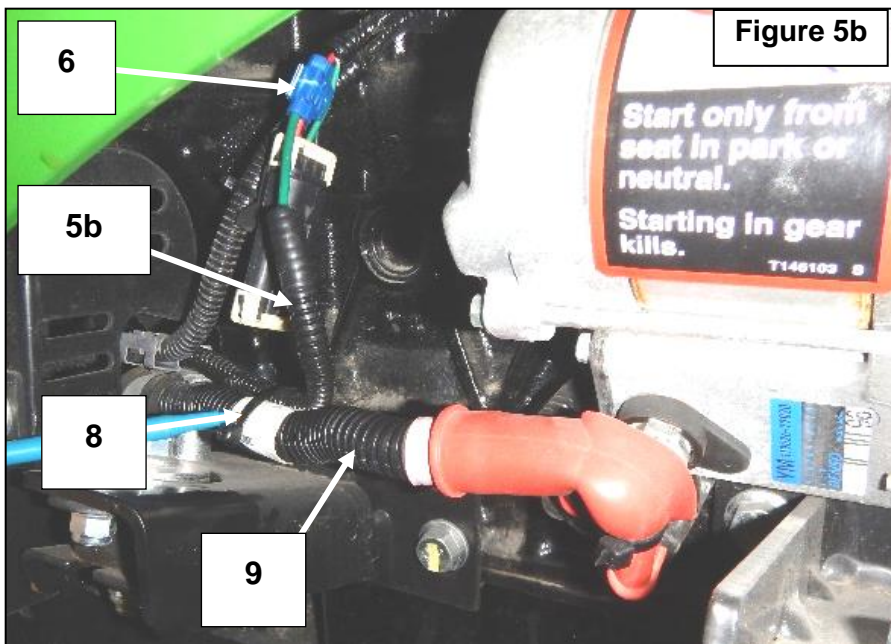
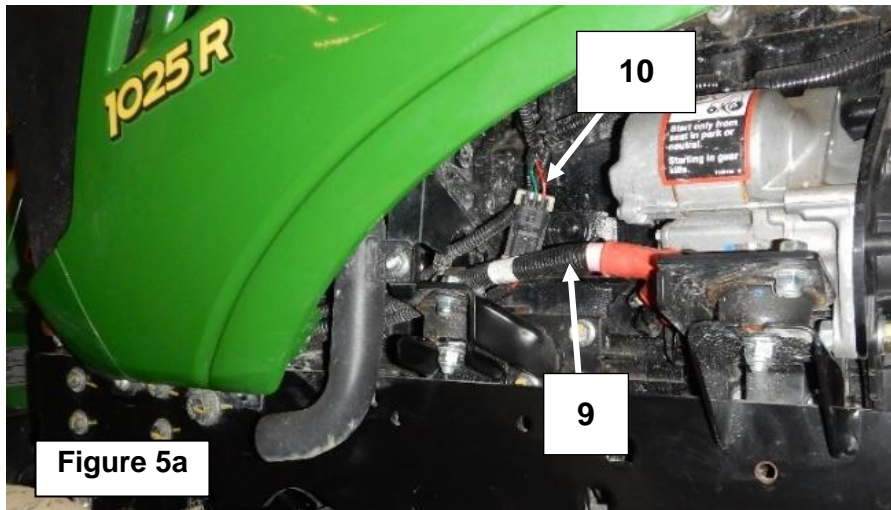

## Installation of the Main Harness #4000172 (Figures 6)

1. **Figure 5:** Passing through the right side of the tractor, cross the section of the main electrical harness (item 11) that contains the black and white wires to the tractor battery location.
2. **Figure 5:** Attach the **black** wire connector (item 11a) to the negative terminal (-) of the battery and the second **black wire to the 85 terminal of the relay** (item 1).
3. **Figure 5:** Attach the **white** wire connector to the **87 terminal of the relay** (item 1).
4. **Figure 5-5b:** Fixer le harnais avec fusible (item 5) et le harnais principal (item 11) aux endroits indiqués sur la figure 8b avec deux attaches de nylon 4.8mm x 8" lg (item 8).

# ASSEMBLY

## Installation of the Main Harness #4000172 (Figures 6) (continued)

5. Group together all items listed in the figures 6 Table.
6. **Figures 6, 6a:** Place the main harness (item 11) to the places shown in the figures and secure with two 4.8mm x 8" lg nylon tie wraps (item 8).
7. **Figures 6b, 6c, 6d, 6e:** Place the main harness (item 11) inside the tractor frame to the places shown in the figures and secure with two 4.8mm x 8" lg nylon tie wraps (item 8).

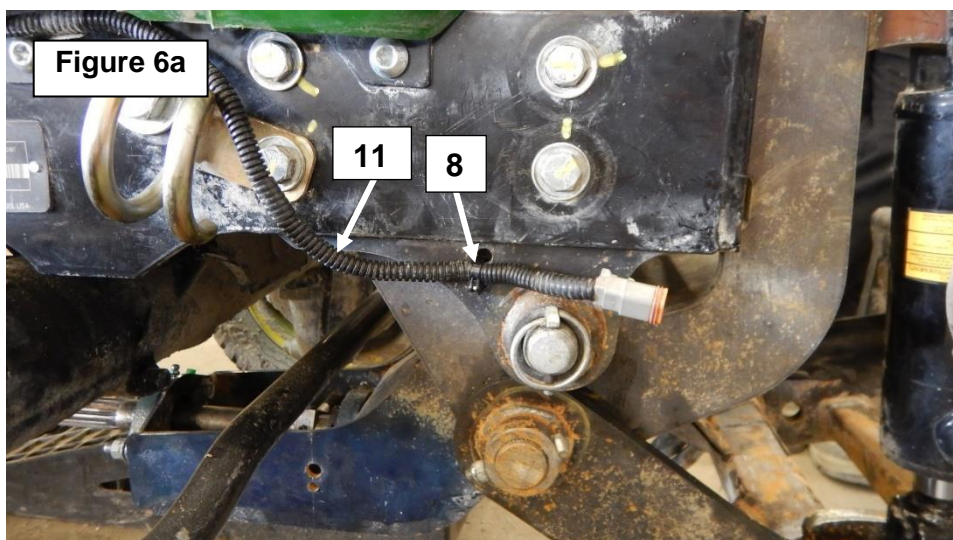
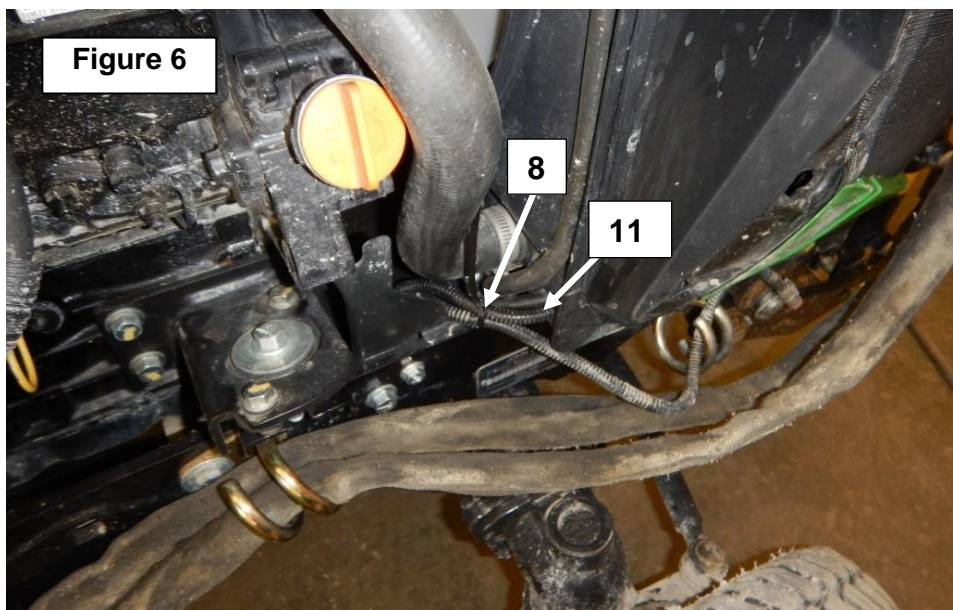

# ASSEMBLY

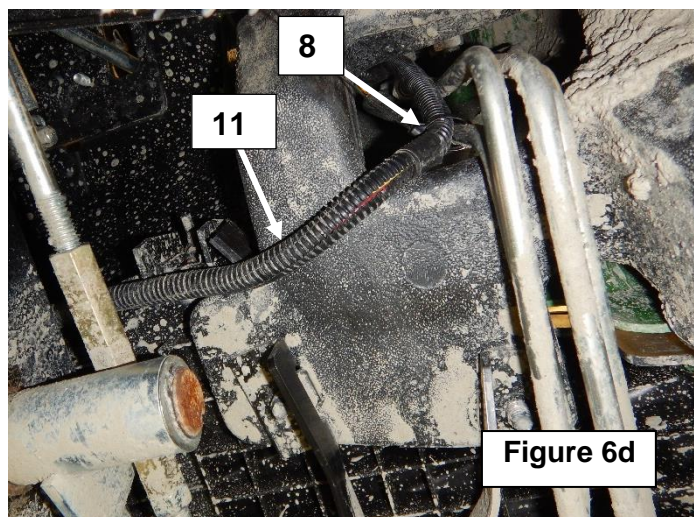
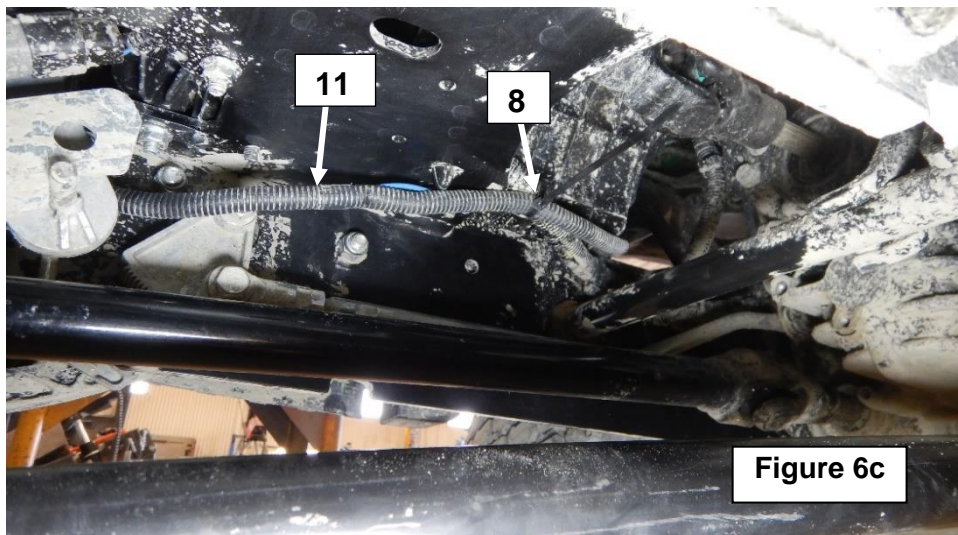
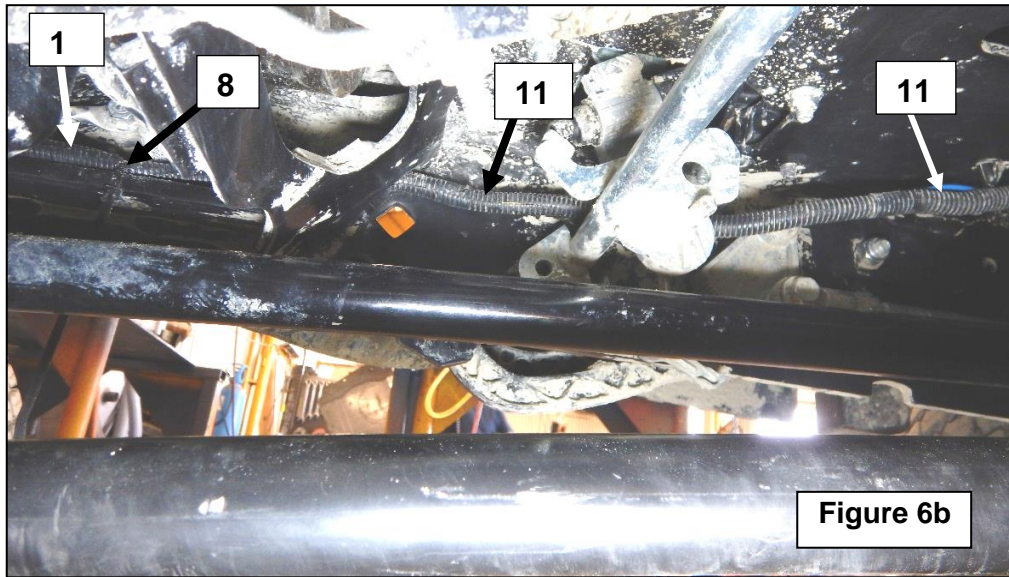

# ASSEMBLY

8. **Figure 6e:** Run the harness (item 11) outside the rubber sheath (item 12) of the hydraulic command lever of the tractor.

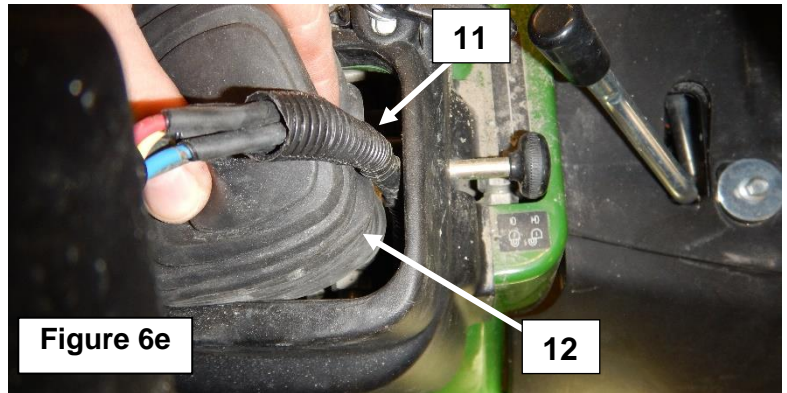

9. **Figures 6f, 6g:** Attach the connectors of the main electrical harness (item 11) to the switch connector (item 20). Attach the **white wire** connector to the switch **20A connector**, the **black wire** to the **20B connector**, the **yellow wire** to the **20C connector** and the **blue wire** to the **20D connector**.

10. **Figure 6g:** Remove the nut (item 20E) of the switch (item 12) and attach the switch (item 12) to the switchbox (item 13) using the switch nut (item 20E).

11. **Figure 6g:** Install the switch rubber cap (item 18) on the switch (item 12).

12. **Figure 6g:** Attach the switchbox (item 13) to the hydraulic valve lever (item 14) of the tractor using the switchbox clamp (item 15) and two 1/4" lockwashers (item 16) and two 1/4"NC x 1" lg hex bolts (item 17).

13. **Figure 6g:** Install the chute deflector decal (item 19) to the location shown in the figure.

14. **Figure 6f:** Attach the main electric harness (item 11) to the lever of the hydraulic command valve (item 14) with a 4.8mm x 8" lg nylon tie wrap (item 8).

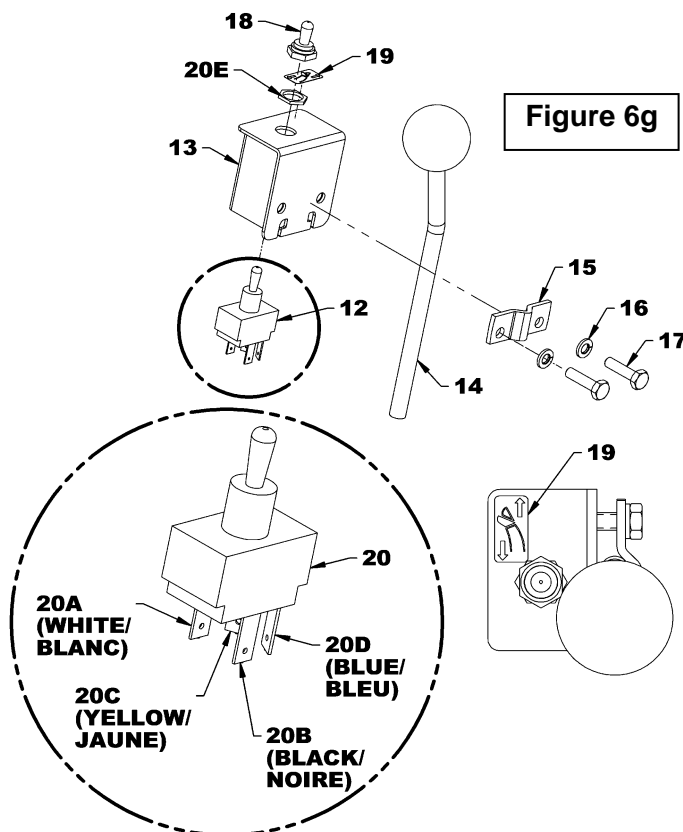
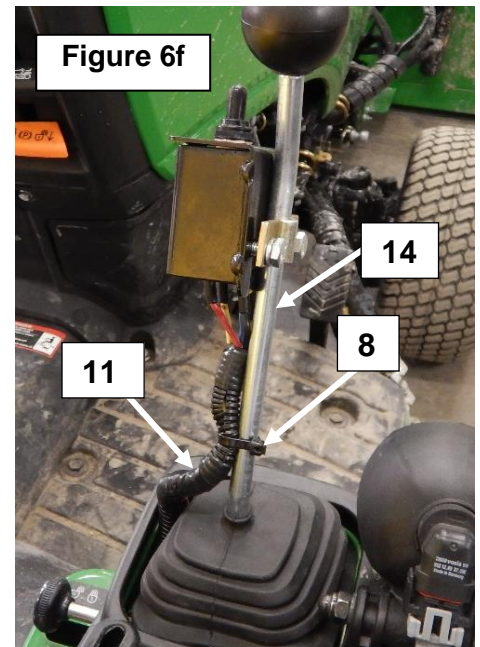

N°	PARTS FOR THE FIGURES 6	QTY
8	NYLON TIE WRAP 4.8mm X 8" LG	6
11	MAIN ELECTRIC HARNESS #4000172 (93 1/2" LG.)	1
12	RUBBER SHEATH	---
13	SWITCHBOX	1
14	HYDR. VALVE LEVER OF THE TRACTOR	---
15	SWITCHBOX CLAMP	1
16	LOCKWASHER 1/4"	2
17	BOLT HEX. 1/4"NC X 1" LG. PTD	2
18	SWITCH RUBBER CAP	1
19	DECAL – CHUTE DEFLECTOR	1
20	SWITCH 4 CONNECTOR	1

# ASSEMBLY

## LUBRICATION

Use a grease gun and lubricate as follows:

DESCRIPTION	INTERVAL	REQUIRED LUBRICATION
Rack	20 hours of operation and at the end of the season	Apply a slight layer of grease on the teeth of the rack and then do some cycles of deflection. Use Shell Gadus S5 V100 grease or equivalent.
Pivot Bushing	20 hours of operation and at the end of the season	Lubricate with heavy chain saw oil.

**IMPORTANT:** Perform all the maintenance section without taking into account the hours given in the following cases:

- At least once a year if the snowblower is used less than 20 hours annually.
- After each wash.
- Before each storage.

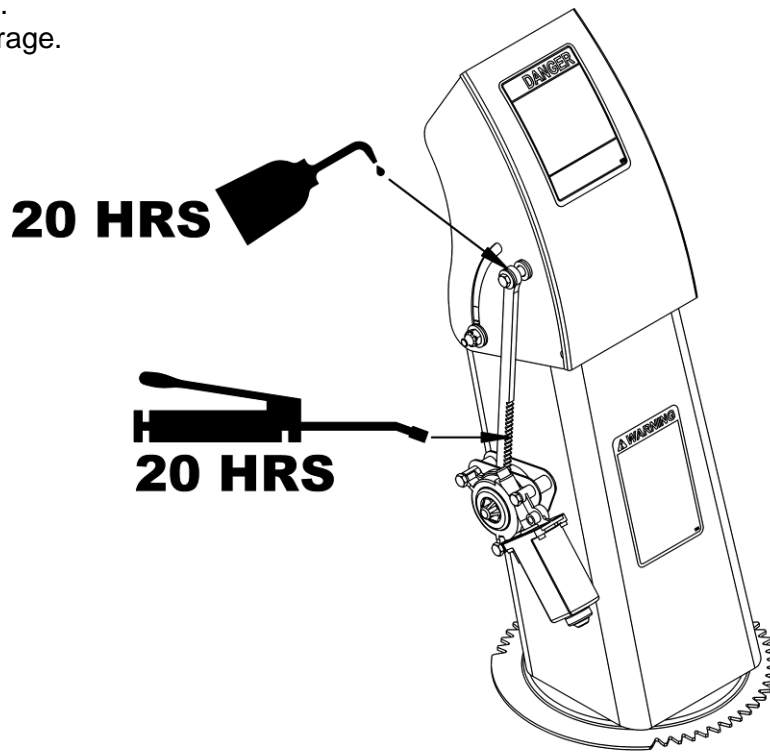

# PARTS

## CHUTE AND ELECTRIC DEFLECTOR

REF.	DESCRIPTION	QTY	PART #
1	Switchbox	1	667557
2	Switchbox clamp	1	667558
3	Guiding plate	2	670154
4	Spacer $\varnothing 3/8"$ x .721 PTD	3	670156
5	Pivot bushing $\varnothing 3/8"$ x 19/32" PTD	1	670157
6	Rack PTD	1	670153
7	Nylon rack guide	1	670155
8	Electric motor	1	662455
9	Bolt hex $\varnothing 1/4"$ NC x 2" Gr.5 PTD	3	0100010
10	Bolt hex $\varnothing 1/4"$ NC x 1 1/4" Gr.5 PTD	1	0100005
11	Nylon insert locknut $\varnothing 1/4"$ NC PTD	4	1000003
12	Flat washer $\varnothing 1/4"$ PTD	1	1400002
13	Nylon flat washer $\varnothing 7/16"$	3	658468
14	Switch 4 blades	1	663383
15	Rubber cap for switch	1	658666
16	Decal – chute deflector	1	2500788
17	Bolt hex $\varnothing 1/4"$ NC x 1" Gr.5 PTD	2	0100004
18	Lockwasher $\varnothing 1/4"$ PTD	2	1200002
19	Relay 12V	1	4000028
20	Machine screw 8-32 x 3/4" round socket head PTD	1	2700011
21	Nylon insert locknut 8-32 PTD	1	1000026
22	Flat washer #8 ( $\varnothing 3/16"$ int) PTD	1	1400001
23	Tap connector	1	656665
24	Electric harness tractor side - deflector	1	4000172
25	Electric harness w/ fuse - deflector	1	4000173
	- Fuse ATO 20 amp.	1	663327
26	Electric harness snowblower side - deflector	1	4000174

# PARTS

## CHUTE AND ELECTRIC DEFLECTOR

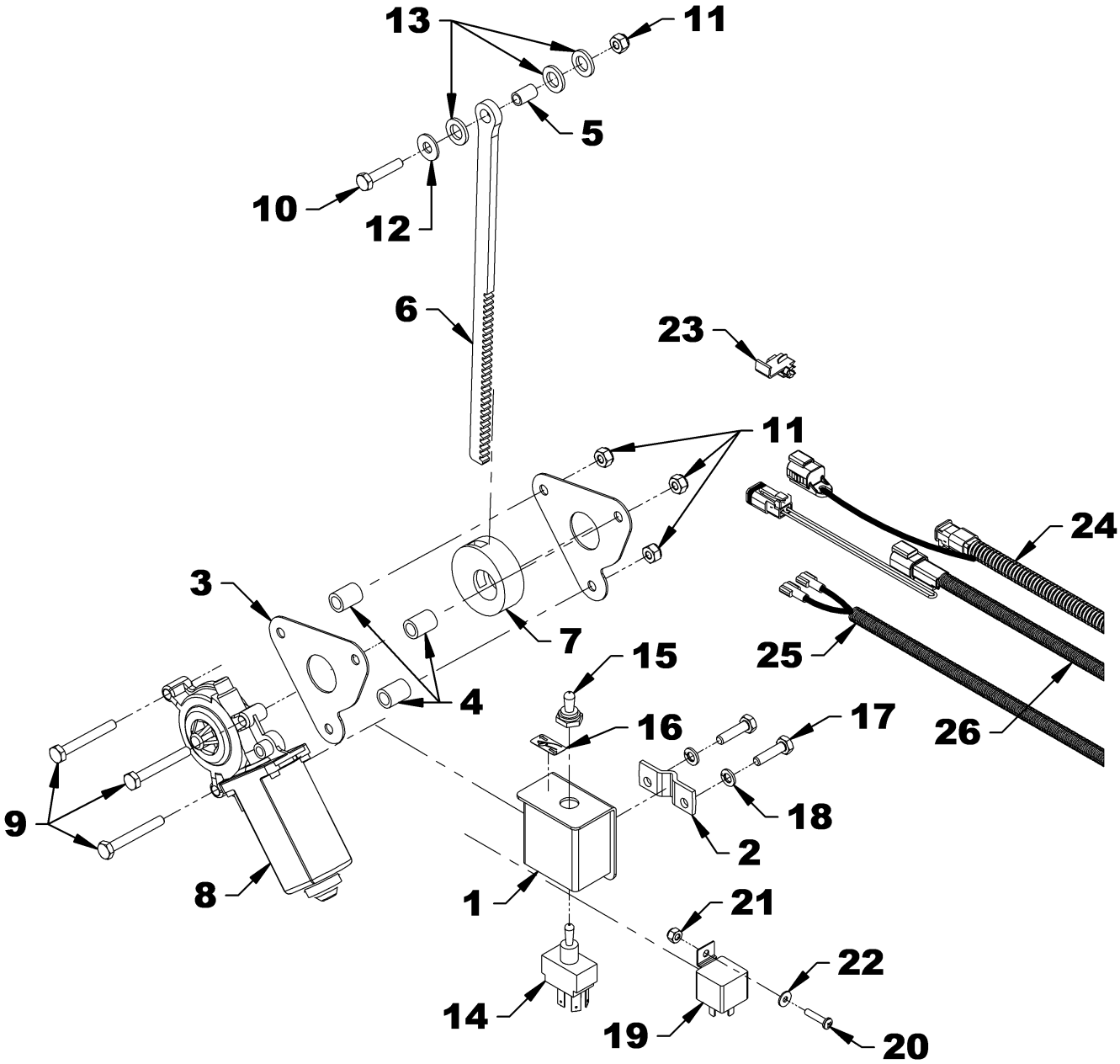

# WARRANTY



RADTECH warrants to the original buyer that the equipment is free from defects in material and workmanship. RADTECH's obligation, under this warranty, will be limited to the repair or replacement of any non-wear part or component, which RADTECH finds to be defective within **one year** from the date of original purchase (unless otherwise-specified). The applicable warranty period for commercial or rental use shall be ninety (90) days from the date of purchase

In no event shall RADTECH be liable for consequential, special, direct or indirect damages incurred by the buyer/user.

All components not manufactured by RADTECH (such as motors, actuators, hydraulic components, tires, ...etc.) are covered by the original manufacturer's warranty in conjunction with RADTECH

RADTECH's obligation under this warranty shall be limited to repairing or replacing, free of charge to the original purchaser, any part that, in RADTECH's judgment, shall show evidence of such defect, provided the **distributor** returns the part prepaid within thirty (30) days from date of failure.

This warranty shall not be interpreted to render RADTECH liable for injuries or damages of any kind or nature to person or property. This warranty does not extend to losses because of delays, or to any expenses or losses incurred for labor, substitute machinery, rental or for any other reason.

Except as set forth above, RADTECH shall have no obligation or liability of any kind on account of any of its equipment and shall not be liable for special or consequential damages. RADTECH makes no other warranty, expressed or implied, and specifically, RADTECH disclaims any implied warranty or merchantability or fitness for a particular purpose. **Some states or provinces do not permit limitations or exclusions of implied warranties or incidental or consequential damages, so the limitations or exclusions in this warranty may not apply.**

This warranty is subject to any existing conditions of supply, which may directly affect our ability to obtain materials or manufacture replacement parts. RADTECH reserves the right to make improvements in design or changes in specifications at any time, without incurring any obligation to owners of units previously sold.

No one is authorized to alter, modify or enlarge this warranty nor the exclusions, limitations and reservations.

***2835 Chemin de l'Aéroport, Thetford Mines (Québec) G6G 5R7***

**T +1 418 338-4499 - F +1 418 338-2522**

info@radtech.ca  
radtech.ca







# TORQUE SPECIFICATION TABLE

## GENERAL SPECIFICATION TABLE

### USE THE FOLLOWING TORQUES WHEN SPECIAL TORQUES ARE NOT GIVEN

Note: These values apply to fasteners as received from supplier dry, or when lubricated with normal engine oil. They do not apply if special graphited or moly sulphide greases or other extreme pressure lubricants are used. These values apply to dry conditions; under lubricated conditions reduce by 25% the torques in this table.

## BOLT HEAD IDENTIFICATION

<b>INCHES Bolt Size</b>	 Grade 2		 Grade 5		 Grade 8		<b>METRIC Bolt Size</b>	 Class 5.8		 Class 8.8		 Class 10.9	
	in-tpi <sup>1</sup>	N-m <sup>2</sup>	lbs-ft <sup>3</sup>	N-m	lbs-ft	N-m		lbs-ft	mm x pitch <sup>4</sup>	N-m	lbs-ft	N-m	lbs-ft
1/4" – 20NC	7.4	5.6	11	8	16	12	M 5 X 0.8	4	3	6	5	9	7
1/4" – 28NF	8.5	6	13	10	18	14	M 6 X 1	7	5	11	8	15	11
5/16" – 18NC	15	11	24	17	33	25	M 8 X 1.25	17	12	26	19	36	27
5/16" – 24NF	17	13	26	19	37	27	M 8 X 1	18	13	28	21	39	29
3/8" – 16NC	27	20	42	31	59	44	M10 X 1.5	33	24	52	39	72	53
3/8" – 24NF	31	22	47	35	67	49	M10 X 0.75	39	29	61	45	85	62
7/16" – 14NC	43	32	67	49	95	70	M12 X 1.75	58	42	91	67	125	93
7/16" – 20NF	49	36	75	55	105	78	M12 X 1.5	60	44	95	70	130	97
1/2" – 13NC	66	49	105	76	145	105	M12 X 1	90	66	105	77	145	105
1/2" – 20NF	75	55	115	85	165	120	M14 X 2	92	68	145	105	200	150
9/16" – 12NC	95	70	150	110	210	155	M14 X 1.5	99	73	155	115	215	160
9/16" – 18NF	105	79	165	120	235	170	M16 X 2	145	105	225	165	315	230
5/8" – 11NC	130	97	205	150	285	210	M16 X 1.5	155	115	240	180	335	245
5/8" – 18NF	150	110	230	170	325	240	M18 X 2.5	195	145	310	230	405	300
3/4" – 10NC	235	170	360	265	510	375	M18 X 1.5	220	165	350	260	485	355
3/4" – 16NF	260	190	405	295	570	420	M20 X 2.5	280	205	440	325	610	450
7/8" – 9NC	225	165	585	430	820	605	M20 X 1.5	310	230	650	480	900	665
7/8" – 14NF	250	185	640	475	905	670	M24 X 3	480	355	760	560	1050	780
1" – 8NC	340	250	875	645	1230	910	M24 X 2	525	390	830	610	1150	845
1" – 12NF	370	275	955	705	1350	995	M30 X 3.5	960	705	1510	1120	2100	1550
1 1/8" – 7NC	480	355	1080	795	1750	1290	M30 X 2	1060	785	1680	1240	2320	1710
1 1/8" – 12NF	540	395	1210	890	1960	1440	M36 X 3.5	1730	1270	2650	1950	3660	2700
1 1/4" – 7NC	680	500	1520	1120	2460	1820	M36 X 2	1880	1380	2960	2190	4100	3220
1 1/4" – 12NF	750	555	1680	1240	2730	2010							
1 3/8" – 6NC	890	655	1990	1470	3230	2380							
1 3/8" – 12NF	1010	745	2270	1670	3680	2710							
1 1/2" – 6NC	1180	870	2640	1950	4290	3160							
1 1/2" – 12NF	1330	980	2970	2190	4820	3560							

- <sup>1</sup> in-tpi = nominal thread diameter in inches-threads per inch
- <sup>2</sup> N-m = newton-meters
- <sup>3</sup> lbs-ft= pounds-foot
- <sup>4</sup> mm x pitch = nominal thread diameter in millimeters x thread Pitch

\*Torque tolerance +0%, -15% of torquing values. Unless otherwise specified use torque values listed above

Manufactured by:



**Dalkotech** Group

RAD Technologies Inc.  
2835, Chemin de l'Aéroport  
Thetford Mines, Québec, Canada, G6G 5R7

**T +1 418 338-4499 - F +1 418 338-2522**

info@radtech.ca  
radtech.ca

Printed in Canada