

**INSTRUCTION SHEET**

**HYDRAULIC ROTATION**

**APPLICATION:** B48C, B54C, B64C and B74C.

**INSTALLATION**

1. Install the chute according to the instructions contained in the snowblower Operator's Manual.
2. **FIGURE 1:** Place the motor spacer (item 2) on the motor top (item 1) by aligning the holes. Install the motor (item 1) under the frame base of the snowblower and secure with four 3/8"NC x 1" bolts (item 3), four 3/8" lockwashers (item 4) and four 3/8" (7/16" hole) flat washers (item 5). Torque slightly.
3. **FIGURE 1:** Make sure the Woodruff key is on the motor shaft and insert the motor gear (item 6) on the shaft. Secure with a 1/4"NC x 3/4" bolt (item 7), a 1/4" lockwasher (item 8) and a 1/4" (5/16" hole) flat washer (item 9).
4. **FIGURE 2: NOT INCLUDED:** Using thread sealant, install a 1/4"NPT female x 1/2"NPT male reducer (item 2), a male quick coupler (item 3) and a dust cap (item 4) on each straight end of the hoses (item 1).

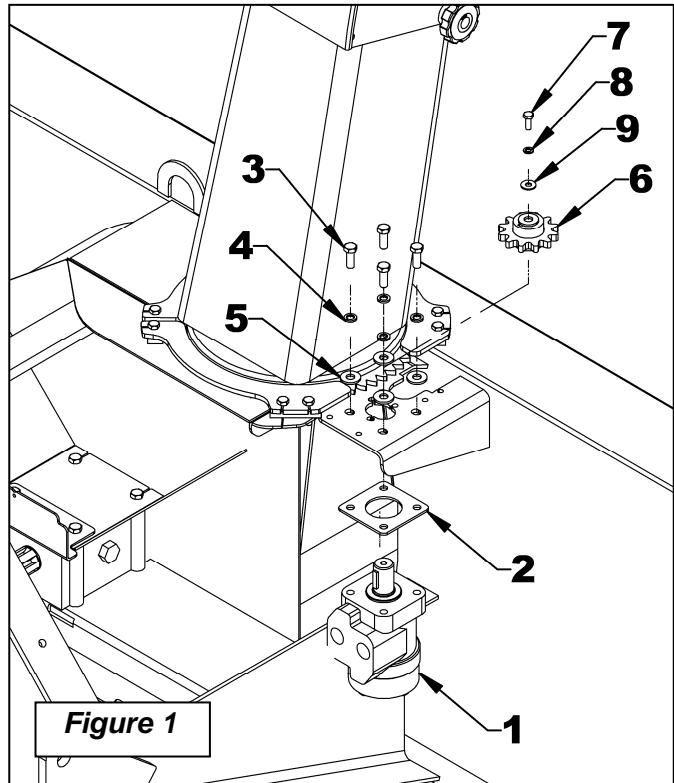
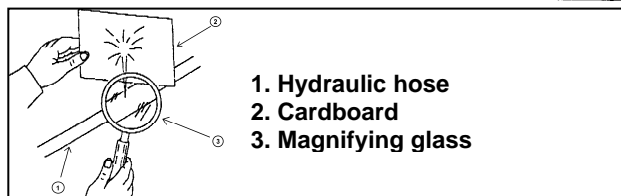
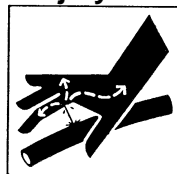

Figure 1

**CAUTION**

To avoid serious personal injury. Escaping hydraulic/ diesel fluid under pressure can penetrate the skin causing serious injury.

- Do not use your hands to check for leaks. Use a piece of cardboard or paper to search for leaks.



1. Hydraulic hose
2. Cardboard
3. Magnifying glass

- Stop engine and relieve pressure before connecting or disconnecting lines.
- Tighten all connections before starting engine or pressurizing lines.
- If any fluid is injected into the skin, obtain medical attention immediately or gangrene may result.

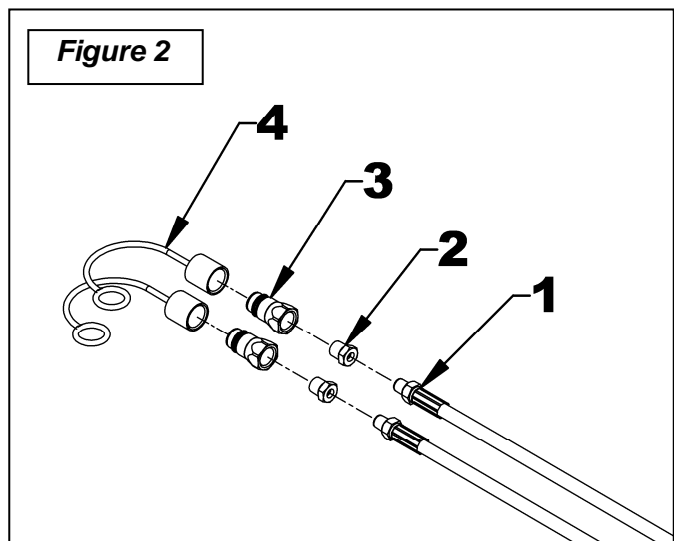
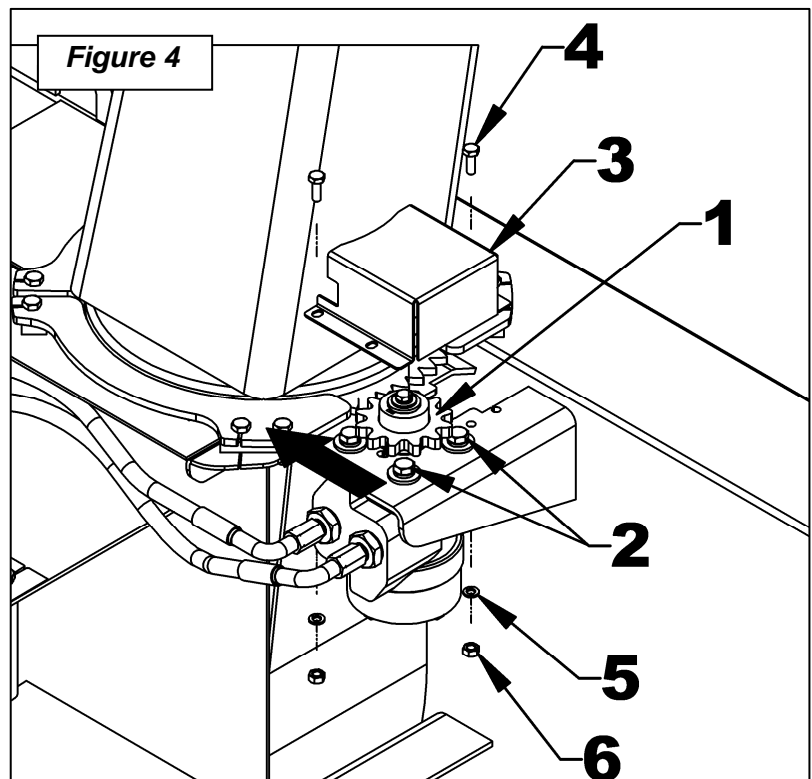
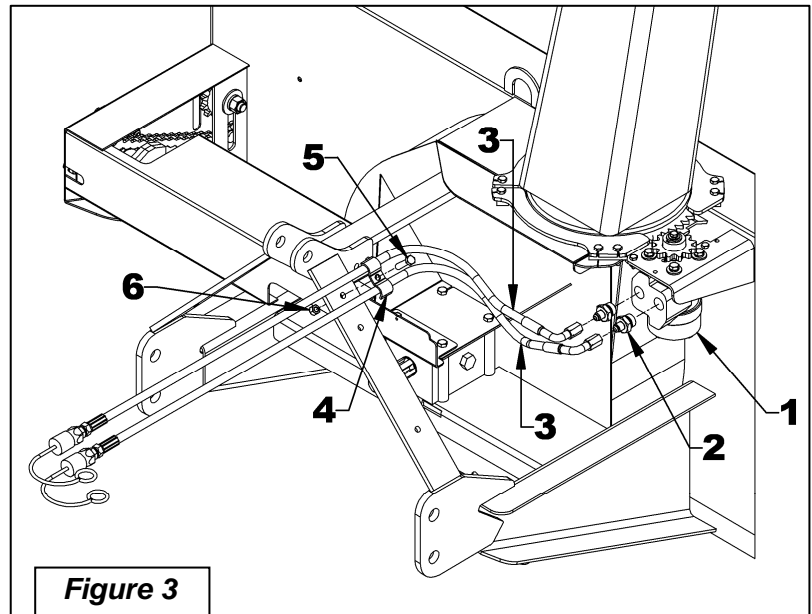

Figure 2

**INSTRUCTION SHEET**
**HYDRAULIC ROTATION**

5. **FIGURE 3:** Install a 0.052" flow restrictor (item 2) in each motor input (item 1).
6. **FIGURE 3: NOT INCLUDED:** Connect the two hoses (item 3) on the motor flow restrictors (item 2). Direct the hose elbows toward the snowblower upper arm.
7. **FIGURE 3: NOT INCLUDED:** Run hoses on the snowblower with suitable bend, staying away from sharp edges, nor compromise the snowblower maintenance. Attach to the right or left snowblower three point arm with a hose clamp (item 4), a 3/8"NC x 1 1/2" bolt (item 5) and a 3/8"NC nylon insert locknut (item 6).
8. **NOT INCLUDED:** Connect hoses to tractor and make sure to raise and lower the snowblower in extreme positions, and check if hoses are long enough to not interfere with any parts. Attach hoses with nylon tie wrap to appropriate places. Rotate the chute to the right and to the left.
9. **FIGURE 4: Motor adjustment:** Push the motor toward the chute as to well set the gear teeth (item 1) without letting any play between teeth. Tighten firmly the four 3/8"NC x 1" bolts (item 2). If the rotation does not operate correctly, redo the adjustment.
10. **FIGURE 4:** Install the gear shield (item 3) and secure with two 1/4"NC x 3/4" bolts (item 4), two 1/4" lockwashers and two 1/4"NC nuts (items 5-6), as illustrated.



**INSTRUCTION SHEET**
**HYDRAULIC ROTATION**
**PROBLEM: HYDRAULIC CHUTE ROTATION IS SLOW OR DOESN'T TURN**

When activating the chute rotation, it turns very slowly or not at all.



**WARNING**

To avoid serious personal injury, always wear safety glasses while doing the instructions below.

**SOLUTION:**

1. Check if the tractor valve works well. Test it by plugging another piece of equipment to the valve. If it does not work well, refer to the appropriate operator's manual.
2. **Figure 1:** Check if the chute itself rotates well. To do so, remove the M6 x 1.00 x 10 mm serrated flange bolt (item 7) and the motor gear (item 6) attached to the motor shaft (item 4) and check if the chute rotates well in both directions by turning it by hand. If it does not rotate well, correct the problem by checking if there is some excess wear or debris locked between components.

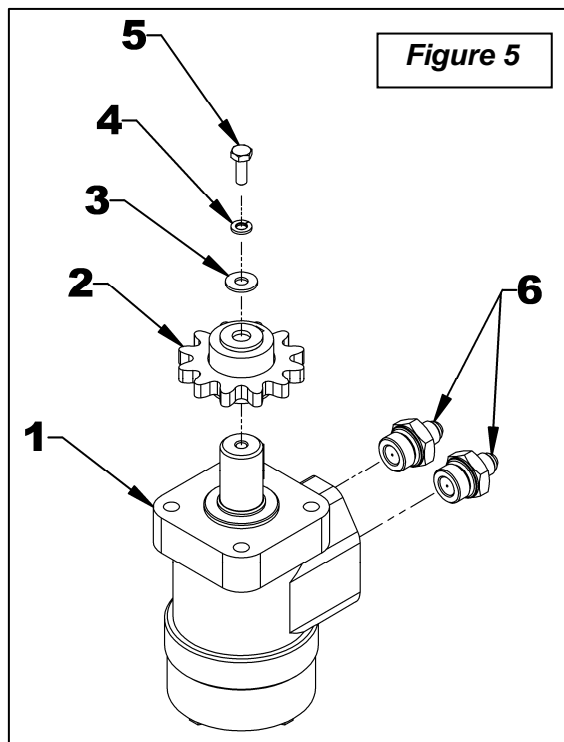
3. **Figure 1:** Check if there is residue in the hydraulic circuit. To do so, first verify if the chute rotates well in one direction. If so, remove the 1/4"NC x 1" bolt (item 5), the 1/4" lockwasher (item 4), the 1/4" flat washer (item 3) and the motor gear (item 2) attached to the motor shaft (item 1) and activate the rotation in the direction the motor turns well for approximately 1 minute to evacuate the residues. Then rotate the chute in the direction it did not turn well and check if the problem is resolved. - If not or if the chute does not rotate well in either direction, disconnect the motor hoses, remove the two flow restrictors (item 5) attached to the motor inputs (item 2) and inspect the holes of the two flow restrictors carefully. Remove the residues if needed. If no residue is present, disconnect hoses and clean them with compressed air. - If the problem persists, check if there is residue inside the motor (item 1). Clean with compressed air the inside of the two motor inputs. You can also manually turn the motor shaft in both directions while shooting compressed air.



**IMPORTANT:** When removing connectors, always make sure to install the plugs and caps on the hoses and tractor valve connectors. This will prevent contamination of the hydraulic circuit and obstruction of the flow restrictor hole.

**INSTRUCTION SHEET**
**HYDRAULIC ROTATION**
**PARTS**

REF.	DESCRIPTION	QTY	PART #
1	Hydraulic motor 50cc	1	3910092
	- Seal Kit	1	3910093
2	Key 1/4" x 1" woodruff (incl. in 3910092)	1	659191
3	Motor gear	1	669705
4	Flow restrictor 0.052"	2	664362
5	Rubber hose 1/4" x 75"lg.	2	666583
6	Reducer 1/4"NPT female x 1/2" NPT male	2	0100040
7	Male quick coupler	2	1000006
8	Dust cap	2	2100009
9	Flat washer 1/4" (5/16" hole) PTD	1	1400002
10	Lockwasher 1/4" PTD	3	1200002
11	Gear shield	1	669715
12	Bolt hex. 1/4"NC x 3/4" PTD	3	0100003
13	Bolt hex. 3/8"NC x 1" PTD	4	0100038
14	Lockwasher 3/8" PTD	4	1200004
15	Flat washer 3/8" (7/16" hole) PTD	4	1400004
16	Motor spacer	1	669718
17	Nut hex. 1/4"NC PTD	2	0900001

