

BER0056 – FRONT SUPPORT FOR LAWN DETHATCHING WHEELS

INSTRUCTION SHEET

APPLICATION

Brooms: HB6032, HB7232, HB7232X, HB8432, HB8432XX, CBR6232, CBR7232, CBR8432

INSTALLATION

1. **Figure 1:** Install the broom on the vehicle and raise it. Take off the two parking stands (item 4) by removing the bolts (item 1), the nuts (item 2) and the square wire lock pins (item 3).

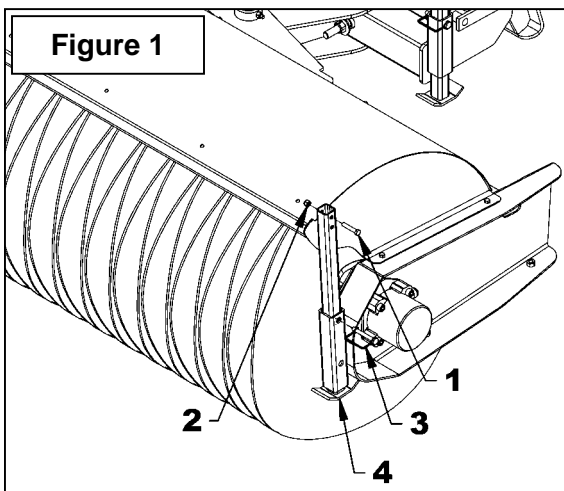

2. **Figure 2 – 84" broom:** Install the left and right wheel supports (items 1-7) on the parking stand tubes (item 2) with two bolts (item 3), four flat washers (item 4), two lockwashers (item 5) and two nylon insert nuts (item 6). Insert the reinforcement tube (item 8) in the tube support (item 9) and secure with four bolts (item 3), eight flat washers (item 4), four lockwashers (item 5) and four nylon insert nuts (item 6). Attach the support tube (item 9) to the left and right wheel supports (items 1-7) with four bolts (item 3), eight flat washers (item 4), four lockwashers (item 5) and four nylon insert nuts (item 6).

NOTE: If the parking stand tubes don't have two holes (item 2) go to step 4 first.

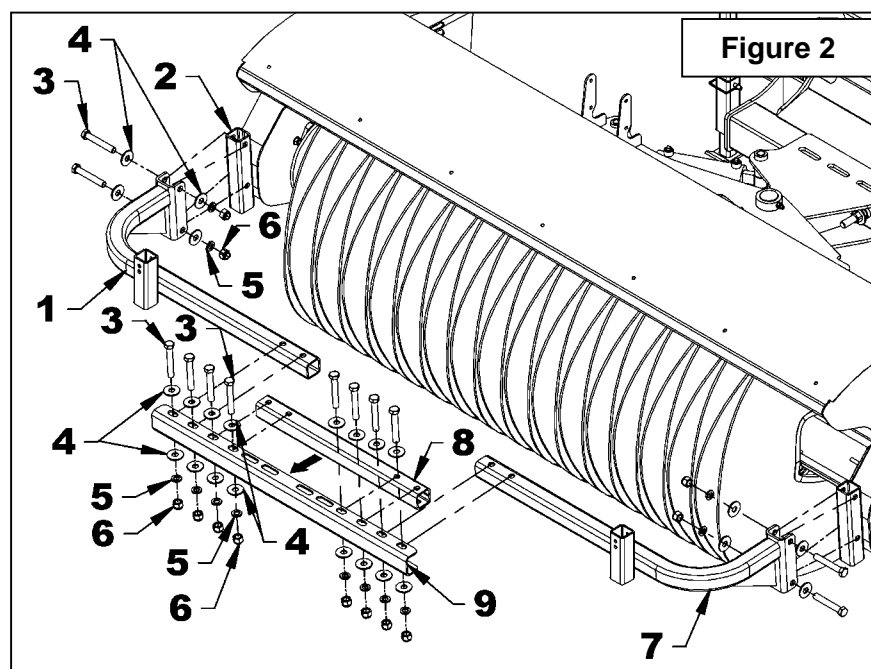

INSTRUCTION SHEET

BER0056 – FRONT SUPPORT FOR LAWN DETHATCHING WHEELS

3. **Figure 3 – 60", 62" and 72" brooms:** Install the left and right wheel supports (items 1-7) on the parking stand tubes (item 2) with two bolts (item 3), four flat washers (item 4), two lockwashers (item 5) and two nylon insert nuts (item 6). Attach the support tube (item 8) to the right and left wheel supports (items 1-7) in the appropriate holes depending on the width of the broom (see figure) with four bolts (item 3), eight flat washers (item 4), four lockwashers (item 5) and four nylon insert nuts (item 6).

NOTE: If the parking stand tubes don't have two holes (item 2) go to step 4 first.

NOTE: The reinforcement tube (Fig. 2, item 8) is not required for the 60", 62" and 72" brooms.

4. **Figure 4:** If the parking stand tube only has one hole, drill the existing hole to a $\frac{21}{32}$ " diameter and drill the second $\frac{21}{32}$ " hole at 5 1/2" from the center and 1" from the edge of the tube as illustrated.

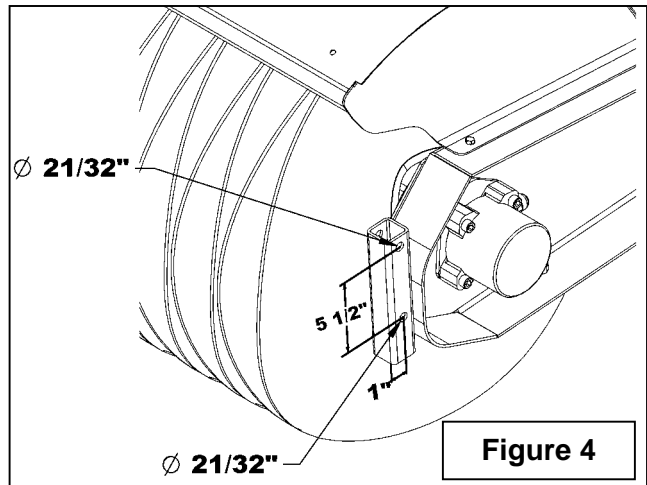

5. **Figure 5:** Install each dethatching wheel (item 1) in the support tubes (item 2) and lock in place with the square wire lock pins (item 3).

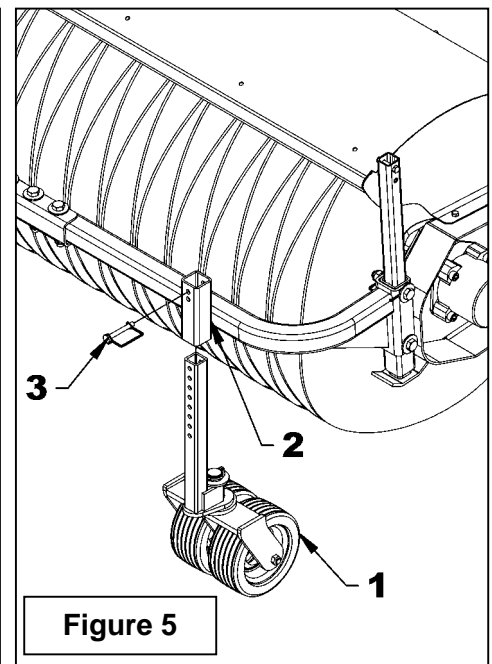
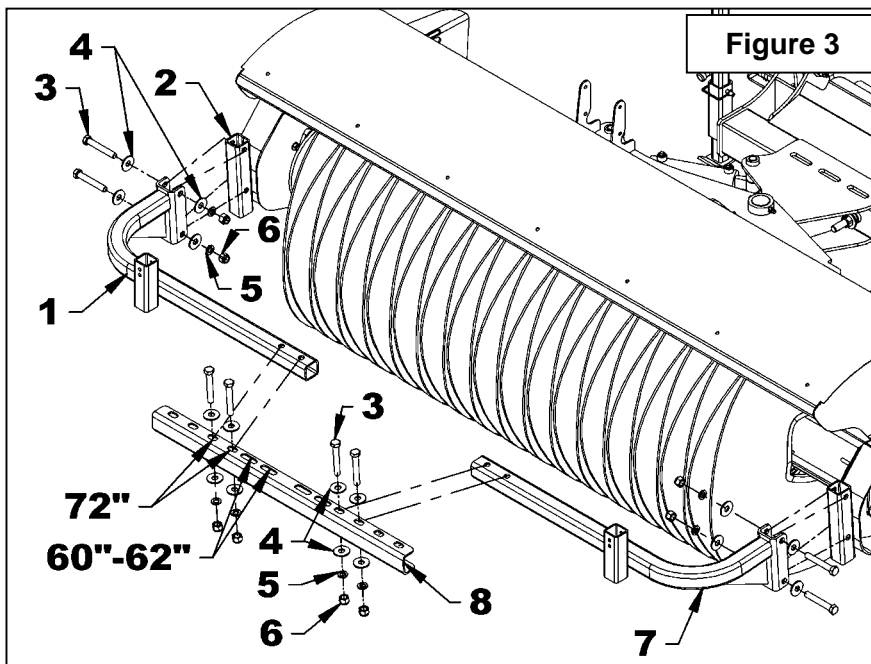

BER0056 – FRONT SUPPORT FOR LAWN DETHATCHING WHEELS

INSTRUCTION SHEET

PARTS

REF.	DESCRIPTION	QTY	PART#
1	Bolt $\phi 5/8$ " NC x 4" lg., PTD	12	O/L
2	Flat washer 5/8" ($\phi 11/16$ " int) PTD	24	O/L
3	Lockwasher $\phi 5/8$ " PTD	12	O/L
4	Nylon insert nut 5/8" NC, PTD	12	O/L
5	Wheel support - RH	1	669099
6	Wheel support - LH	1	669100
7	Reinforcement tube	1	669102
8	Tube support	1	669101

O/L – Obtain Locally

