



## INSTRUCTION SHEET

## 9480 – ELECTRIC NOZZLE ROTATION

### ELECTRIC NOZZLE ROTATION

1. If equipped with a manual rotation: remove the rotation mechanism referring to your debris's operator manual. Remove the three bolts that hold the retaining plate to the debris blower and keep them for a later use.
2. **Figure 1:** Install the 1 1/16" plastic bushing (item 1) inside the motor support (item 2).
3. **Figure 1:** Install the worm adaptor (item 3) on the motor shaft and secure motor (item 4) to the support (item 2) using three 1/4" x 2" bolts, spacers and serrated flange nuts (items 5-6-7). Tighten.
4. **Figure 1:** Insert longest tube end of rotation worm (item 9) over adaptor (item 3) and into plastic bushing in motor support. Align holes and secure with a 10-24 x 1" capscrew and a nylon lock nut (items 10-11). Tighten securely.
5. **Figure 1:** Install the 1 5/16" plastic bushing (item 12) inside the welded tube of the retaining plate (item 13).
6. **Figure 1:** Install the assembly on the debris blower using the hardware kept previously. Torque to 9-11 ft-lb.
7. Tighten the allen set screws (item 8) on the worm adaptor (item 3).

**IMPORTANT:** Do not tighten the allen set screws (item 8) right now.

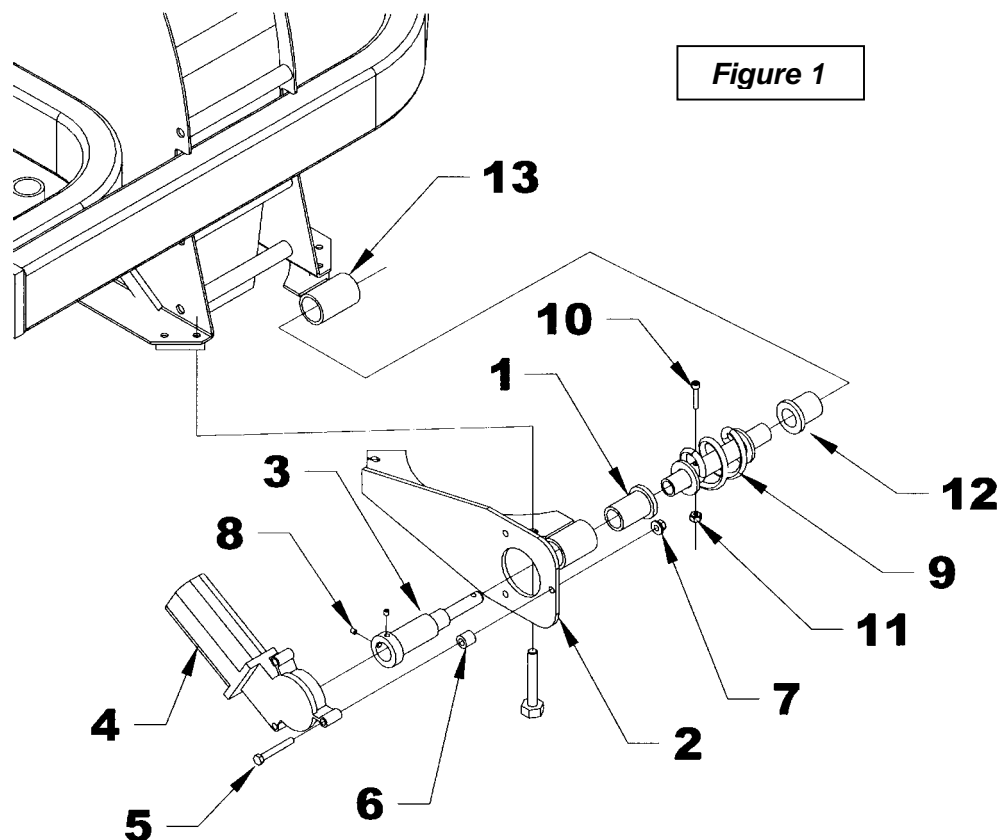



## INSTRUCTION SHEET

## 9480 – ELECTRIC NOZZLE ROTATION

8. Locate an appropriate place on the tractor to install the control switch and drill one 1/2" hole to the selected place. Drill one .593" hole at least 2 1/2" from control switch hole for fuse holder. The two holes must be drilled in an appropriate location and must not interfere with existing controls or electrical systems.
9. **Figure 2:** Solder one 18" wire to the side terminal of fuse holder and the other 18" wire to the bottom terminal.
10. Install control switch and fuse holder in holes drilled previously and thread rubber toggle protector over switch.

11. **Figure 2:** Connect one wire from fuse holder to middle terminal of control switch, the other 18" wire to the tractor ignition switch.
12. Connect one end of the long lead wire to the electric motor and the other end to the control switch. Cut this wire at a convenient length for blower removal. Install the wire connectors with one male and one female connector to the motor half of the wire. This will allow the blower to be easily dismantled.
13. Secure wires away from moving parts using the provided tie wraps.

**NOTE:** If chute rotates opposite to direction of control switch, simply reverse motor lead wires.

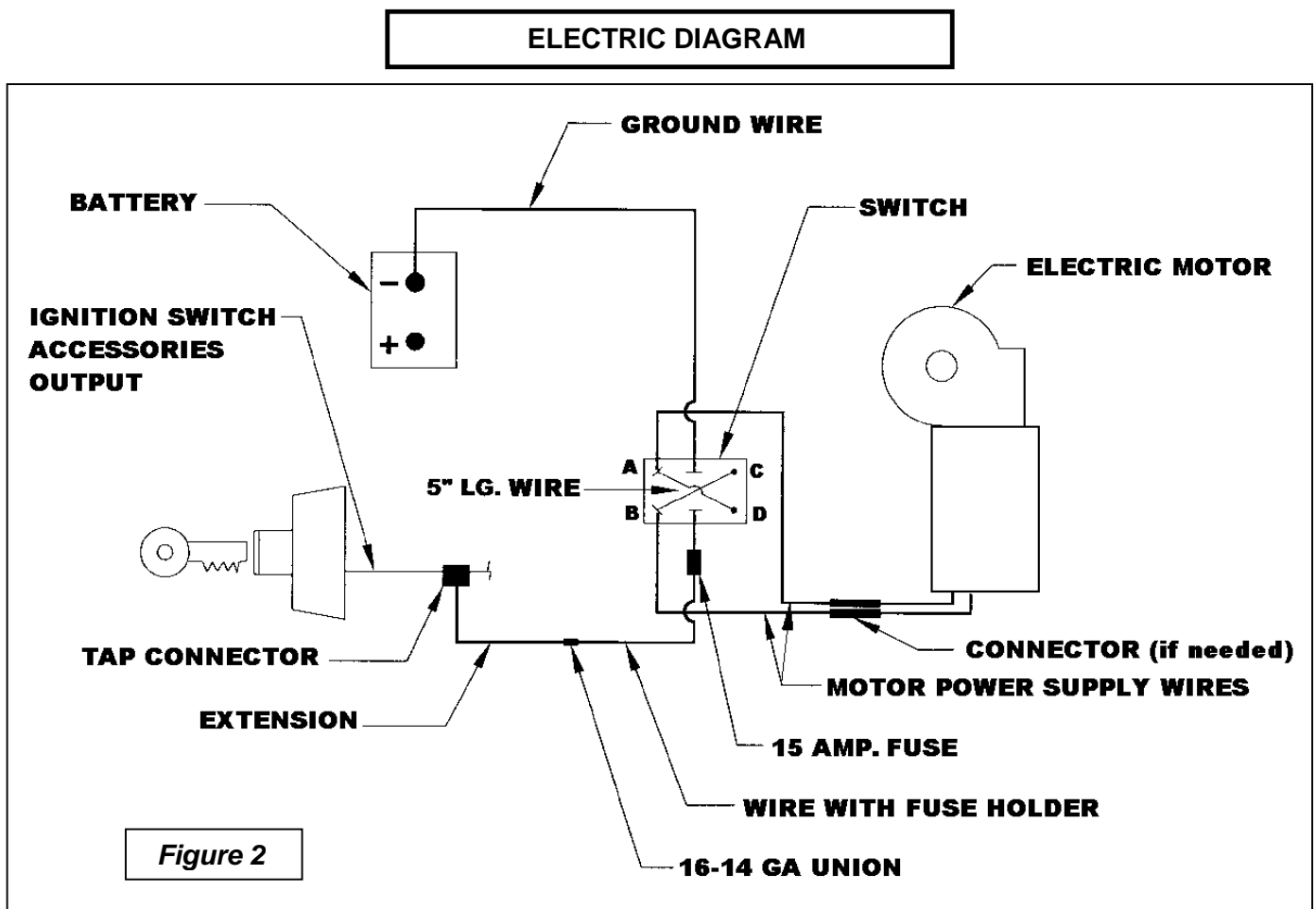



**INSTRUCTION SHEET**

**9480 – ELECTRIC NOZZLE ROTATION**

**ELECTRIC NOZZLE ROTATION - 9480 (OPTION)**

REF.	DESCRIPTION	QTY	PART #
1	Electric motor support	1	662491
2	Rotation worm	1	660246
3	Worm adaptor	1	662489
4	Electric motor	1	662455
5	Plastic bushing 1 11/16"	1	657336
6	Plastic bushing 1 5/16"	1	657335
7	Spacer 5/8" lg PTD	3	666691
8	Bolt hex. 1/4" NC x 2" PTD	3	O/L
9	Serrated flange nut 1/4" PTD	3	O/L
10	Allen socket head cap screw #10-24NC x 1" PTD	1	O/L
11	Nylon insert lock nut #10-24NC PTD	1	O/L
12	Allen set screw 1/4" NF x 1/4"	2	O/L
13	Wire 16GA x 5", black	2	655441
14	Wire 16GA x 17", black	1	655442
15	Double wire 16GA x 102"	1	662468
16	Wire 16GA x 18", black, 2 terminals	1	660692
17	Wire 16GA x 18", black, 1 terminal	1 <td 660323	
18	Switch	1	658778
19	Rubber cap for switch	1	658666
20	Fuse support	1	658665
21	Fuse 15 amp.	1	O/L
22	Connector tap	1	656665

