



## INSTRUCTION SHEET

## 9464 – SECOND AUGER KIT

### Second Auger Conversion Kit (Option) (Figure 4)

1. Remove the front guard and loosen the idler sprocket. Remove the lower auger chain and the bolts on each side of the lower auger bearings. Remove the auger from the snowblower.
2. Install the new sprockets (items 6 & 19) on both augers.
3. Reinstall lower and upper augers with the bolts and bearings supplied. Do not tighten setscrews on the bearings now.
4. Install idler sprocket (item 7) on chain idler support (item.3) as shown. Assemble support inside snowblower in the pre-bored holes.
5. Install the chain (item 5) as shown on figure 4. Align the auger's sprockets with the idler sprocket and tighten securely the setscrews on the auger bearings to stabilize the augers.
6. Install the new chain guard (item 2) supplied with the optional upper auger. Reinstall the lower auger chain and the front guard.

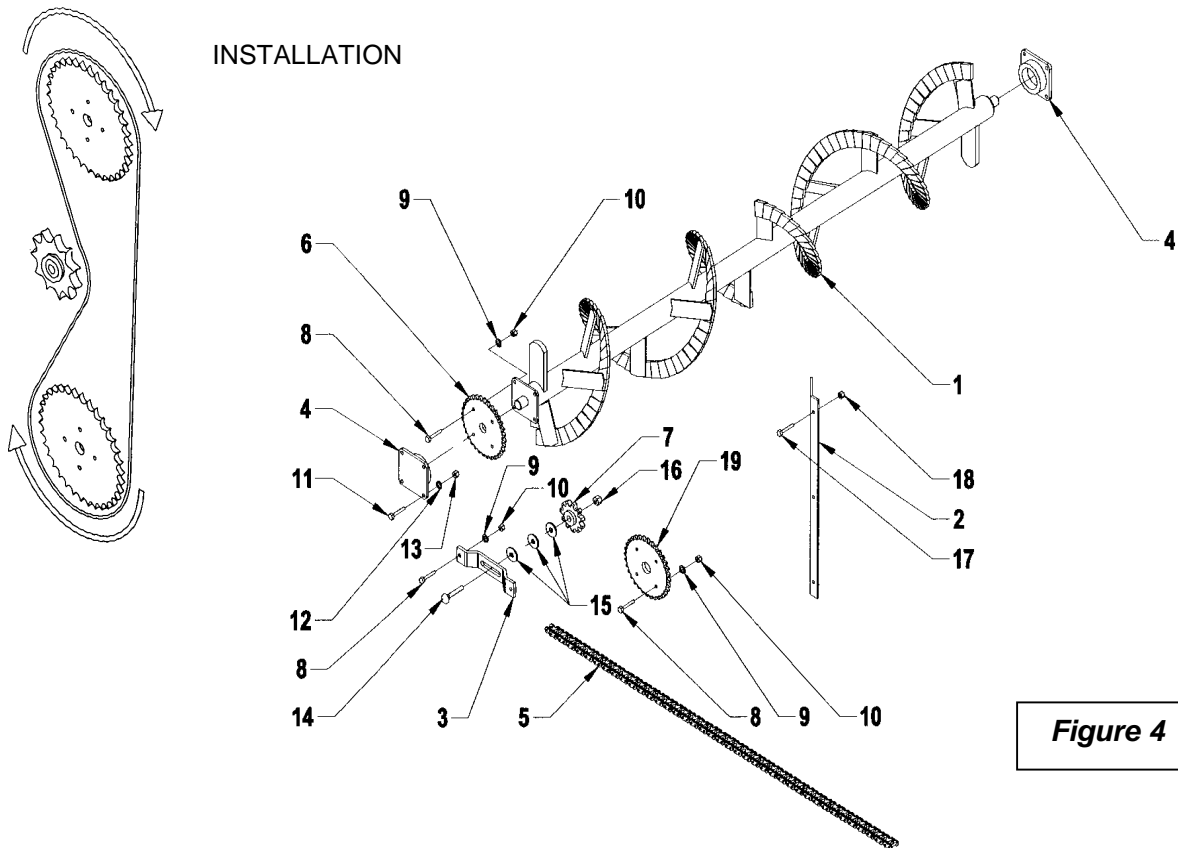

Figure 4



**INSTRUCTION SHEET**

**9464 – SECOND AUGER KIT**

**SECOND AUGER CONVERSION KIT - 9464**

REF.	DESCRIPTION	QTY.	PART NUMBER
			<b>SA104TRC</b>
1	Upper auger	1	662442
2	Chain guard	1	662443
3	Chain idler support	1	655782
4	Bearing 1 1/4" dia. hole, 4 holes	2	4300001
5	Chain #60 x 83 links & connecting link	1	662447
6	Sprocket # 60 A 32 hole 1 1/4" dia.	1	654167
7	Idler sprocket CA60	1	654010
8	Hex. bolt 3/8" NC x 1 1/4"	10	O/L
9	Lockwasher 3/8"	10	O/L
10	Hex. nut. 3/8" NC	10	O/L
11	Hex. bolt 1/2" NC x 1 1/2"	8	O/L
12	Lockwasher 1/2"	8	O/L
13	Hex. nut 1/2" NC	8	O/L
14	Carriage bolt 5/8" NC x 2 1/2"	1	O/L
15	Flatwasher 11/16" dia. hole	3	O/L
16	Hex. nut 5/8" NC, nylon	1	O/L
17	Hex. bolt 3/8" NC x 1"	3	O/L
18	Hex. nut 3/8" NC, nylon	3	O/L
19	Sprocket # 60 A 32 hole 1 1/2" dia.	1	662444

