



INSTRUCTION SHEET

9370 ELECTRIC DEFLECTOR

INSTALLATION ON DEBRIS BLOWER

1. Remove the plastic knob from deflector and replace existing bolt by a 5/16" x 3/4" carriage bolt (item 7). Secure with the original nylon washer and supplied nylon nut (item 8). Leave 1/16" play.
2. Install the actuator support plate (item 1) on right hand side of nozzle (item 2) using two 1/4" x 3/4" bolts (item 3) and 1/4" NC flange nuts. Torque to 13 ft. lbs.
3. Attach actuator base to support plate, using a 1/4 x 1 1/2 (10-24 NC) shoulder screw (item 4), spacer (item 5), flat washer and a 10-24 NC nylon hex. nut. Tighten to allow free movement.
4. Insert stopper sleeve (item 6) on actuator rod. Attach actuator rod end to deflector using the 1/4 x 2 1/4 bolt, spacer, flat washer and 10-24 NC nylon hex. nut. Tighten to allow free movement.
5. Drill a 1/2" hole in tractor for control switch. Drill a .593" hole at least 2 1/2" from control switch hole for fuse holder. The two holes must be drilled in an appropriate location and must not interfere with existing controls or electrical system.

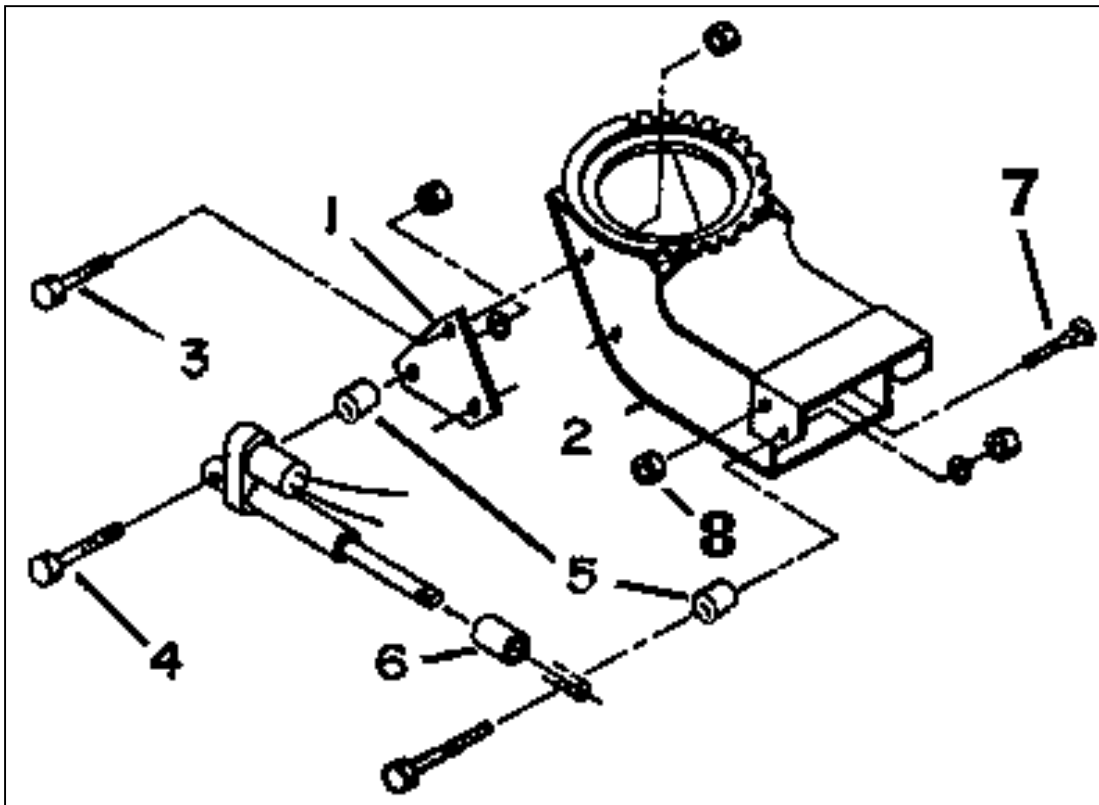



INSTRUCTION SHEET

9370 ELECTRIC DEFLECTOR

NOTE: Refer to Electrical diagram.

6. Weld one 18" wire to fuse holder side terminal and the other 18" wire with eyelet to the bottom terminal.
7. Install control switch and fuse holder. Screw rubber protector on switch.
8. Connect eyelet of 18" wire to "b" terminal of control switch.
9. Connect one end of the 17" wire to "e" terminal on control switch and other end to a suitable ground on tractor frame.
10. Connect one end of a 5" wire to a terminal and the other end to "d" terminal on control switch.
11. Connect one end of other 5" wire to "c" terminal and other end to "f" terminal on control switch.
12. Attach eyelet end of the 102" double wire to "a" and "f" terminals on control switch.
13. Connect fuse wire to wire from tractor ignition switch "AC" terminal using connector tap.
14. Connect free end of the double wire to the actuator. Cut this wire at a convenient location for blower removal. Install the wire connectors with one male and one female connector to the actuator half of the wire.
15. Secure wires away from moving parts using the provided tie wraps and adhesive clips.

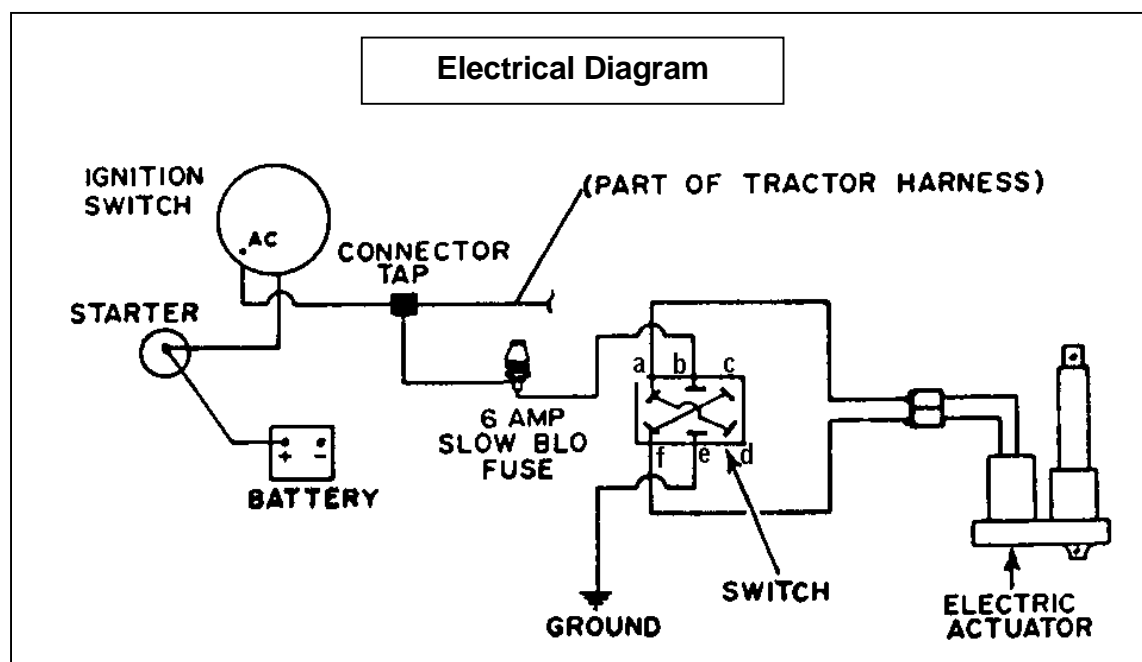

INSTRUCTION SHEET

9370 ELECTRIC DEFLECTOR

INSTALLATION ON SNOWBLOWER

1. Remove manual adjustment knobs and bolts from sides of deflector and replace them with two 5/16" x 3/4" carriage bolts. Secure with the original nylon flat washers and supplied nylon nuts. Leave approximately 1/16" play.
2. Drill two 9/32" dia. Holes in chute as shown on figure.
3. Attach the actuator (item 1) to the chute with two 1/4" x 1 1/2" (10-24 NC) shoulder screws (item 3), two spacers (item 2), two flat washers (item 4) on the outside and 10-24 NC nylon hex. nut. Place screws in the actuator and slip the spacers on the screws so that the screws do not protrude the nuts (item 5) once threaded.
4. Weld one 18" wire to fuse holder side terminal and the other 18" wire with eyelet to the bottom terminal.
5. Install control switch and fuse holder. Screw rubber protector over switch.
6. Connect eyelet of 18" wire to "b" terminal of control switch.
7. Connect one end of the 17" wire to "e" terminal on control switch and other end to a suitable ground on tractor frame.
8. Connect one end of a 5" wire to a terminal and other end to "d" terminal on control switch.
9. Connect one end of other 5" wire to "c" terminal and other end to "f" terminal on control switch.
10. Attach eyelet end of the 102" double wire to "a" and "f" terminals on control switch.
11. Connect fuse wire to wire from tractor ignition switch "AC" terminal using connector tap.
12. Connect free end of the double wire to the actuator. Cut this wire at a convenient location for blower removal. Install the wire connectors with one male and one female connector to the actuator half of the wire.
13. Secure wires away from moving parts using the tie wraps and adhesive clips.

NOTE: Refer to Electrical diagram.

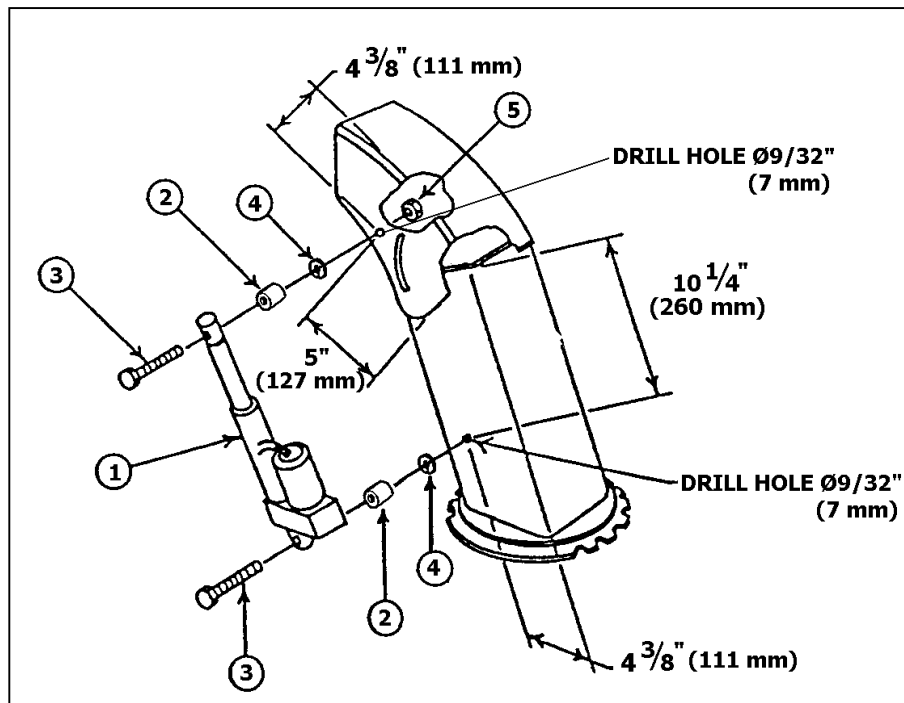



INSTRUCTION SHEET

9370 ELECTRIC DEFLECTOR

PARTS

| REF. | DESCRIPTION | QTY | PART # |
|------|---|-----|--------|
| 1 | Support plate | 1 | 665773 |
| 2 | Spacer | 2 | 665774 |
| 3 | Actuator | 1 | 656848 |
| 4 | Shoulder screw 1/4" x 1 1/2" (10-24 NC) | 2 | O/L |
| 5 | Nylon hex. nut (10-24 NC) | 2 | O/L |
| 6 | Hex. Bolt 1/4" NC x 3/4" | 2 | O/L |
| 7 | Flange nut 1/4" NC | 2 | O/L |
| 8 | Connector tap | 1 | 656665 |
| 9 | Carriage bolt 5/16" NC x 3/4" (snowblower) | 2 | O/L |
| | Carriage bolt 5/16" NC x 3/4" (debris blower) | 1 | O/L |
| 10 | Nylon nut 5/16" NC (snowblower) | 2 | O/L |
| | Nylon nut 5/16" NC (debris blower) | 1 | O/L |
| 11 | Stopper sleeve | 1 | 661102 |
| 12 | Connector | 2 | 656664 |
| 13 | Double wire ass'y 102" | 1 | 660695 |
| 14 | Connector female | 2 | 657853 |
| 15 | Connector male | 2 | 655217 |
| 16 | Wire ass'y 5" | 2 | 655441 |
| 17 | Wire ass'y 17" | 1 | 655442 |
| 18 | Control switch | 1 | 658778 |
| 19 | Rubber toggle protector | 1 | 658666 |
| 20 | Wire ass'y 18" | 1 | 660692 |
| 21 | Fuse holder | 1 | 658665 |
| 22 | Fuse 6 amp. | 1 | 657285 |
| 23 | Wire 16 ga x 18" | 1 | 660323 |
| 24 | Flat washer 3/16" | 1 | O/L |
| 25 | Flat washer 1/4" | 1 | O/L |

