



INSTRUCTION SHEET

8238- LAWN DETHATCHING WHEEL KIT

INSTALLATION

1. **Figure 1:** Install the left bracket and the right bracket (item 1) on each side of the housing using seven 3/8" NC x 3/4" hex. flange bolts (item 3) and 3/8"NC hex. nuts (item 4).
2. **Figure 1-2:** Insert the tube of the left side caster wheel (fig. 1, item 2) into the wheel bracket (fig. 1, item 1) and secure in place with a square lock pin (fig. 2, item 1).
3. Repeat the same procedure for the right wheel.
4. To adjust the height of the wheel (1/4" at a time minimum), remove the square lock pin (fig. 2, item 1), slide the inner tube upward or downward, as needed, and reinsert the square lock pin in the visible hole.

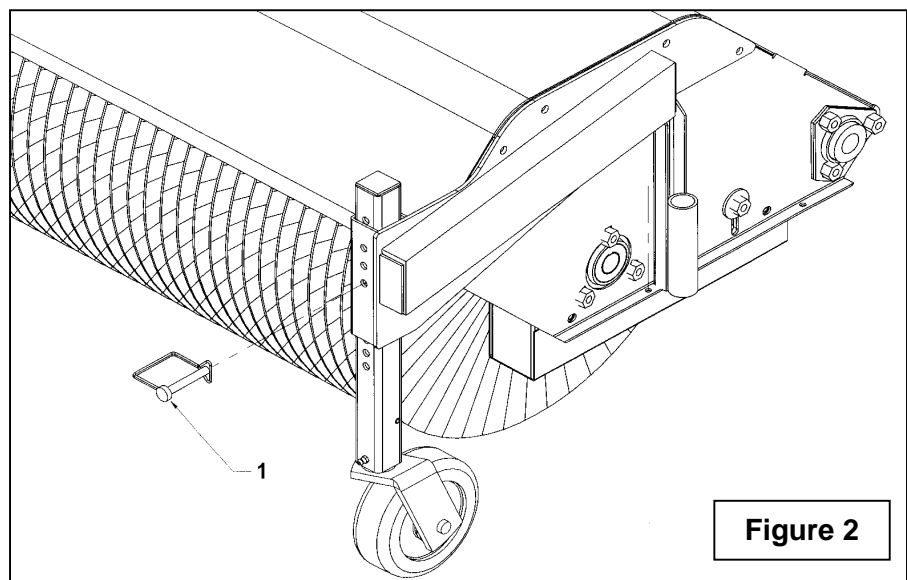
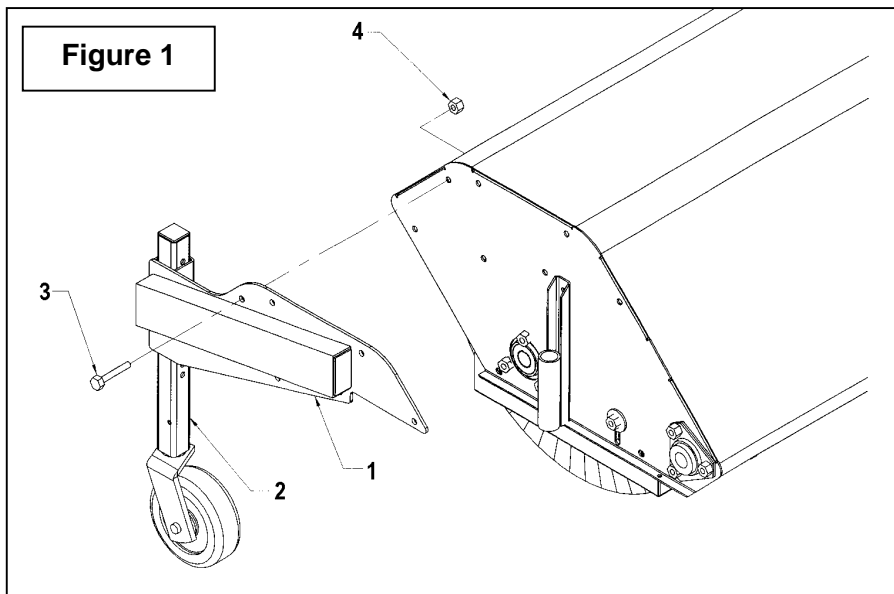



INSTRUCTION SHEET

8238- LAWN DETHATCHING WHEEL KIT

PARTS

REF.	DESCRIPTION	QTY	PART #
1	Right bracket	1	665517
2	Left bracket	1	665516
3	Adjustment tube	2	665518
4	Wheel bushing	2	660948
5	Right wheel bracket	1	661298
6	Left wheel bracket	1	661297
7	Wheel 6" diam. X 2"	2	661306
8	Grease fitting 1/4" NF	2	654106
9	Serrated flange bolt 3/8" NC x 3/4"lg., gr. 2, PTD	14	O/L
10	Nut hex. 3/8"NC PTD	14	O/L
11	Roll pin 1/4" x 1 1/2", black	2	O/L
12	Flat washer 13/16" hole, PTD	2	O/L
13	Flat washer 11/16" hole, PTD	4	O/L
14	Cotter pin 1/4" x 1 1/2", PTD	2	O/L
15	Square wire lock pin 3/8" x 2 1/2"	2	O/L

O/L= Obtain locally

