



## INSTRUCTION SHEET

## 8235 UPDATE KIT ROTATION BY MOTOR

### APPLICATION

SA92IA snowblowers with serial # 2028772 to 2028781 and SET11013 to SET11022

### INSTALLATION (Figures 1-2)

1. **Figure 1:** Remove the cover (item 1). Remove the motor gear (item 2) by unscrewing the bolt (item 3) of the motor (item 4). Keep at hand the motor gear, key, bolt and washers.
2. **Figure 1:** Remove the four bolts (item 5) that fix the motor (item 4).

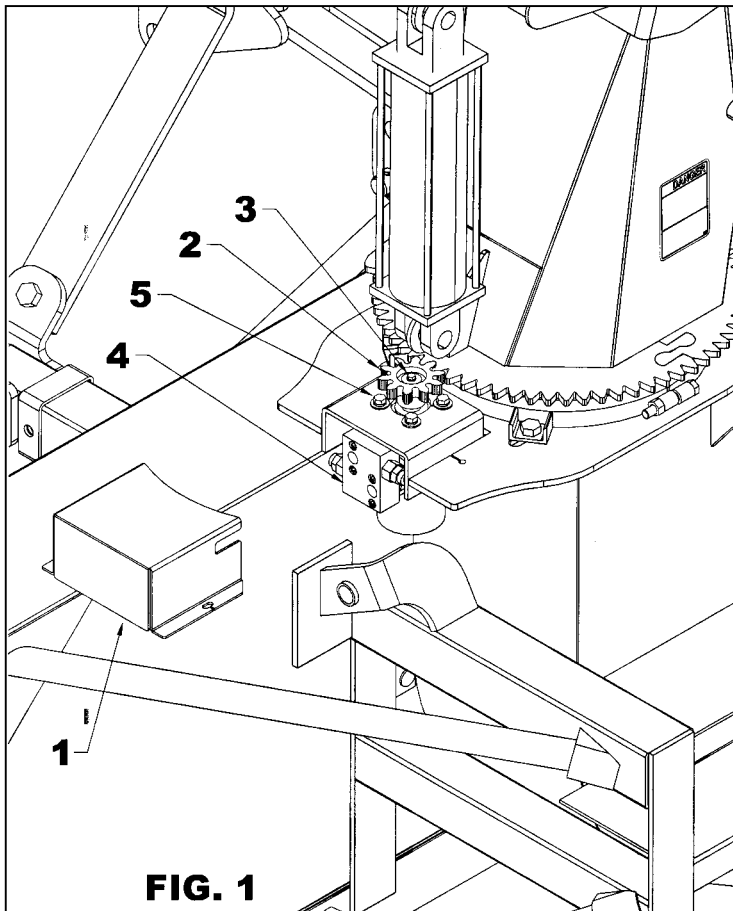

3. **Figure 2:** Reinstall the motor (item 1) placing it above the new anchor plate (item 2) as shown on figure. Attach with four 3/8"NC x 1" lg (item 3) hex. bolts and lockwashers. Tighten manually.
4. **Figure 2:** Reinstall the motor gear with the key, bolt (item 4) and washers previously removed. Tighten according to the Torque Specification Table located at the end of your snowblower manual manual.
5. **Figure 2:** Insert the anchoring flat bar (item 5) between the anchor plate (item 2) and the motor support as shown on figure. Screw the 3/8NC nuts (item 6) at maximum on the two 3/8"NC x 1 1/2" lg bolts (item 7). Install those two bolts (item 7) by screwing them in the anchoring flat bar (item 5).



## INSTRUCTION SHEET

## 8235 UPDATE KIT ROTATION BY MOTOR

6. **Figure 2:** Adjust the distance between the chute gear and the motor gear according to the following step:

- A- Slightly unscrew the two bolts (item 8) that hold the retaining plate.
- B- Screw the two nuts (item 9) simultaneously until the distance between the retaining plates and the chute base is leveled.
- C- Retighten the bolts (item 8) according to the Torque Specification Table located at the end of the manual.
- D- Adjust the gears with a distance of  $1/32"$  to  $1/16"$  by screwing the two bolts (item 7). Secure with the nuts (item 6) moving them against the anchoring flat bar (item 5). Tighten the four bolts (item 3) according to the Torque Specification Table located at the end of the manual.
- E- Run a test at low speed. If the gears make irregular sound while testing, it means the adjustment is incorrect. Bring parts closer to each other until the sound becomes regular and even.

7. Reinstall the cover.

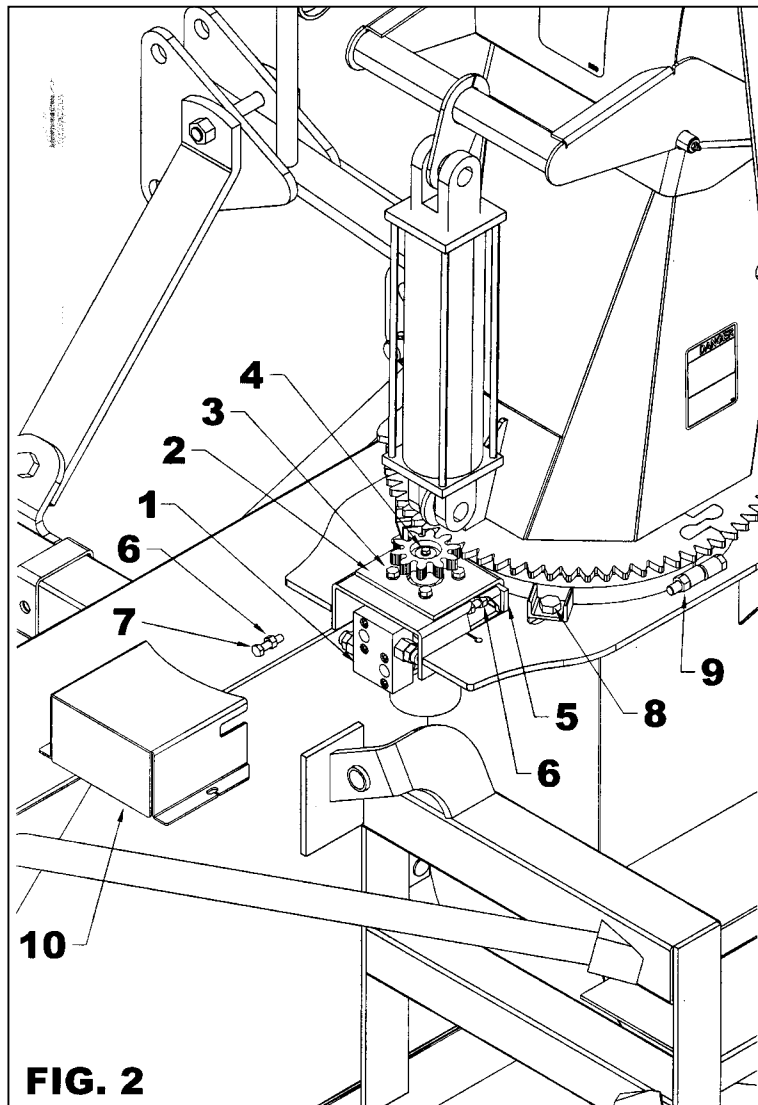

**FIG. 2**



# INSTRUCTION SHEET

# 8235 UPDATE KIT ROTATION BY MOTOR

## PARTS

REF.	DESCRIPTION	QTY	PART #
1	Anchor plate	1	667338
2	Anchoring flat bar	1	667339
3	Lockwasher 3/8", PTD	4	O/L
4	Hex. bolt 3/8" NC x 1" lg gr.5 PTD	4	O/L
5	Hex. bolt 3/8" NC x 1 1/2" lg gr.5 PTD	2	O/L
6	Hex. nut 3/8" NC PTD	2	O/L

