



## INSTRUCTION SHEET

## 8184 - HYDRAULIC DEFLECTOR

### **INSTALLATION** – 64": 2" X 6" Cylinder Kit 8155 required – 76": 3" X 8" Cylinder Kit 8150 required

**NOTE:** Refer to the Diagram of Hydraulic & Electrical Circuits at all times.

1. Shut engine off and remove the ignition key
2. **Figure 1:** For a 64" snowblower: Install the 2" x 6" cylinder (item 1) in the hole farthest from the chute pointing the cylinder rod up and the clevis bolt toward the exterior. Block the cylinder clevis with two 1" pin (item 2) and 4 hairpins (item 13).
3. **Figure 2:** For a 76" snowblower: Install the 3" x 8" cylinder (item 1) on the pointing the cylinder rod up and the clevis bolt toward the exterior. Block the cylinder clevis with two 1" pin (item 2) and 4 hairpins (item 13).
4. **Figure 1A:** Remove a hairpin (item 3) on the 1" pin (item 2) located on the rod end of the rotation cylinder, Insert the hose support (item 4) in the 1" pin and reinstall the hairpin.
5. **Figure 1or 2 depending on the snowblower model, H64 or H76:** Install the 9/16" ORB male x 9/16" JIC male adaptors (item 10) on each manifold port (item 26). ATTENTION: In order to distinguish adaptors and flow restrictors, refer to the figure below.
6. Install the manifold (item 26) on the right side (position "B") of the snowblower using two #10-24 x 1 1/4" socket head capscrew and #10-24 nylon insert nut (items 25-27)
7. Place the 9/16" fitting of the 1/4" x 45" hose (item 7) on the manifold's port "T" du (item 4) and the bent fitting of the 1/4" x 37" hose (item 6) on port (P). Do not tighten immediately.
8. On upper port "A" and lower port "B", install a 1/4" x 83" hoses (item 5) on each 9/16" x 9/16" adapter (item 10 Do not tighten immediately.

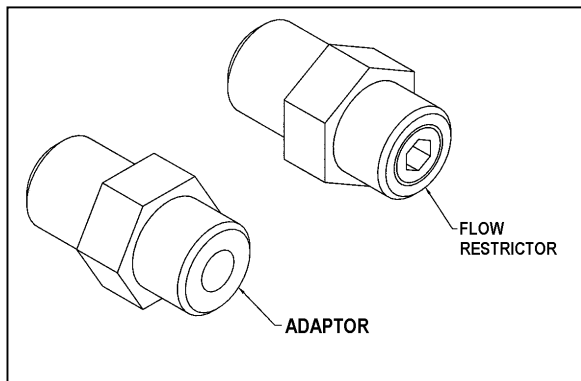



# INSTRUCTION SHEET

# 8184 - HYDRAULIC DEFLECTOR

## Hose Installation 2" x 6" cylinder (H64)

(Figures 1-1A:

9. Install the teflon coated male NPT end of the 90° elbow (item 9) in each cylinder port (item 1). See figure 2A for position of elbows.
10. Attach the teflon coated 3/8 NPT end of the 1/4" x 83" hose (item 5) connected on top of the valve (item 4) to the upper cylinder port (item 1) inserting first in the hose support (fig, 9A, item 4). Connect the other 1/4" x 83" (item 5) hose in the other cylinder port inserting it first in the hose support (fig, 1A, item 4). Do not tighten immediately.

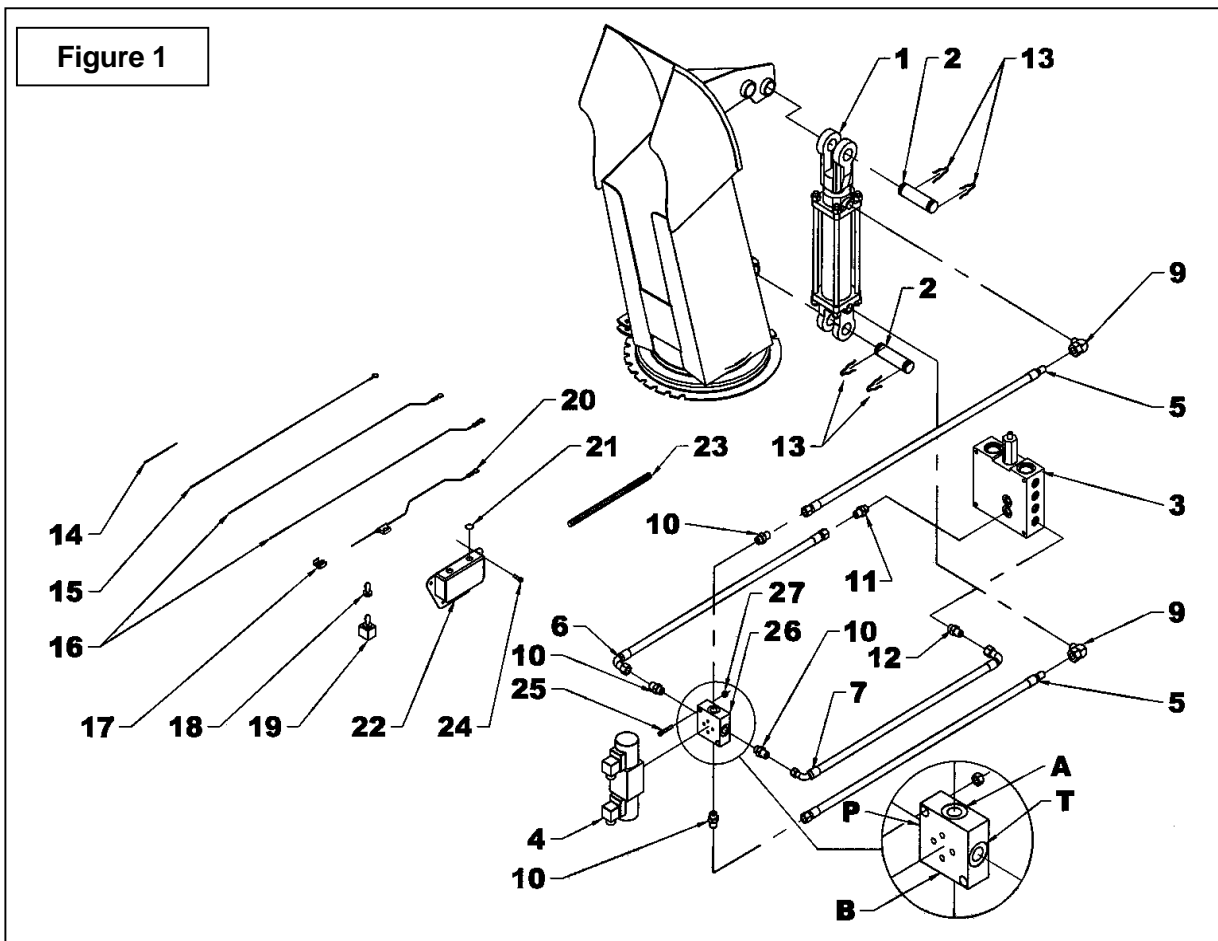
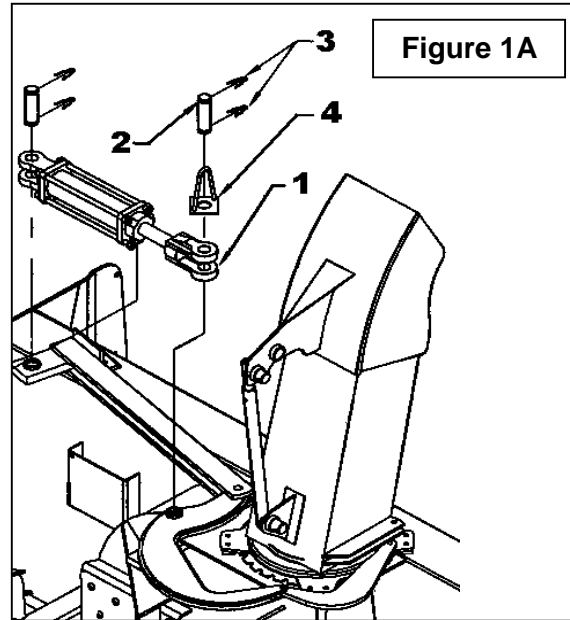



# INSTRUCTION SHEET

# 8184 - HYDRAULIC DEFLECTOR

## Hose Installation 3" x 8" cylinder (H76) (Figures 2-2A)

11. Install a teflon coated 1/2" male x 3/8" fem. adapters (item 8) on each cylinder port (item 1) and the teflon coated male NPT end of a 90° elbow (item 9) on each reducer (item 8). See figure 2A for positions of elbows
12. Attach the teflon coated 3/8 NPT end of the 1/4" x 83" hose (item 5) connected on top of the valve (item 4) to the upper cylinder port (item 1) inserting first in the hose support (fig, 1A, item 4). Connect the other 1/4" x 83" (item 5) hose in the other cylinder port inserting it first in the hose support (fig, 1A, item 4). Do not tighten immediately.

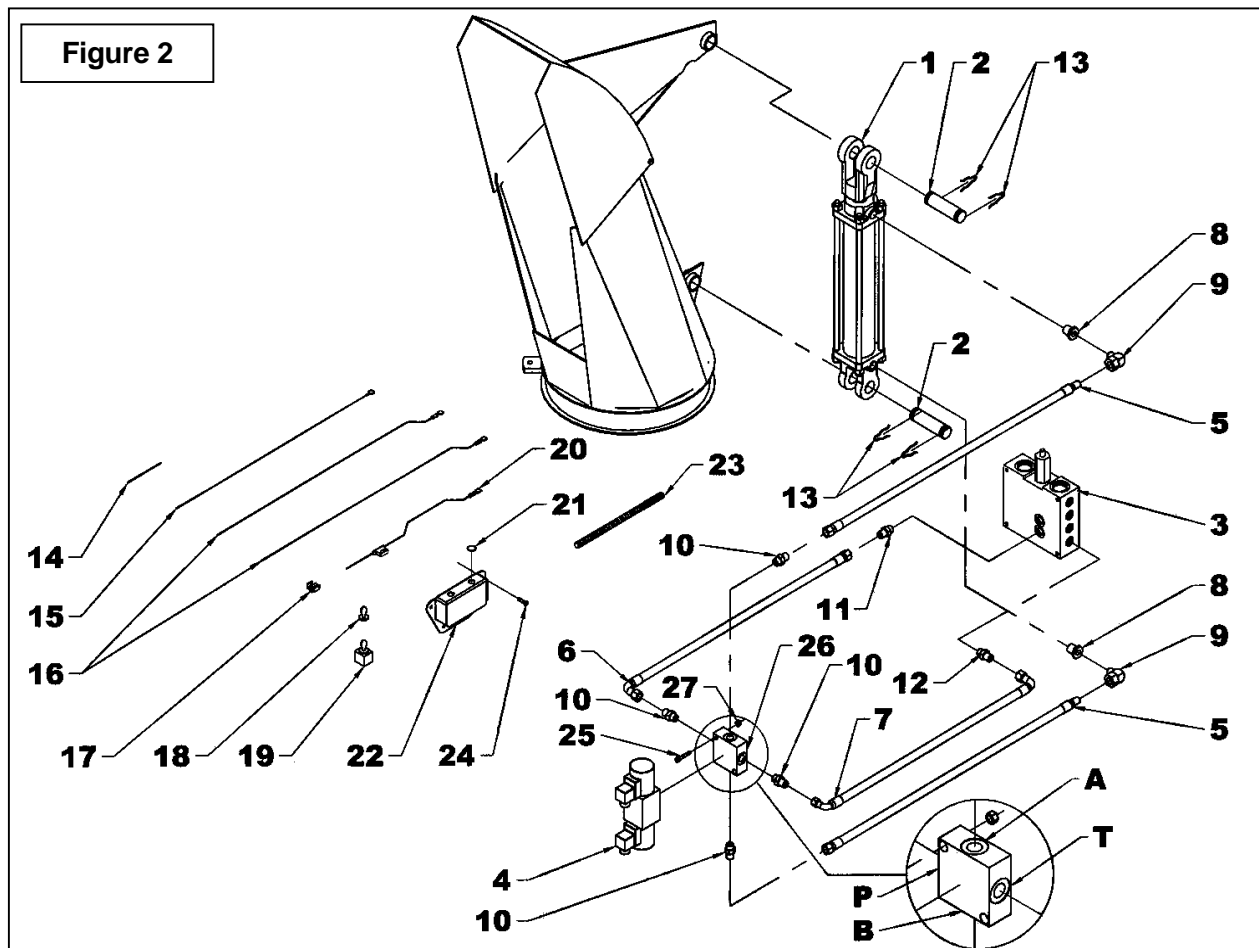
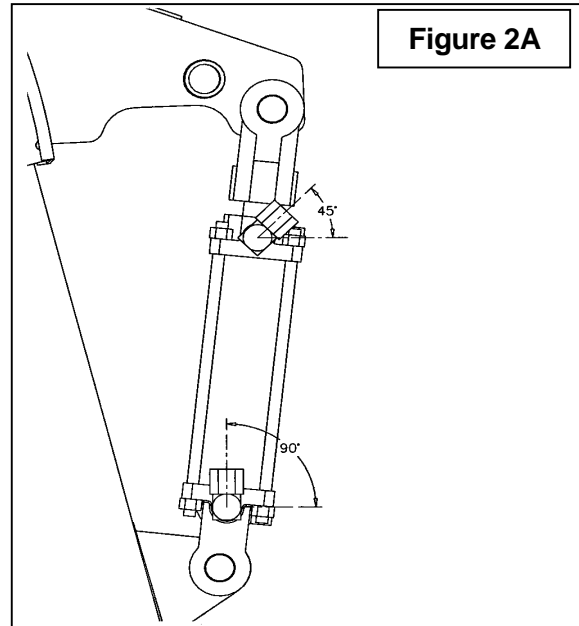



# INSTRUCTION SHEET

# 8184 - HYDRAULIC DEFLECTOR

**(Figure 1 or 2) H64 & H76:**

13. Insert a flow restrictor (item 11) on the front of the snowblower manifold (item 3) and connect the 1/4" x 37" hose (item 6). Do not tighten immediately.
  14. Insert a 7/16" ORB male x 7/16" JIC male adapter (item 12) on the side of the snowblower manifold (item 3) and connect the 1/4" x 45" hose (item 7). Tighten all the hoses making sure they are positioned properly.
  15. Assemble the electro-hydraulic valve (item 4) with the manifold (item 27), using the socket head capscrews supplied with the electro-hydraulic valve. Tighten all the hoses.
  16. Connect the two 360" white wires (item 16) to the terminals at each end of the switch (item 19) and the white 72" wire (item 20) in the middle of the switch as shown on figure 11a.
- NOTE:** The wires must be connected to the 3 terminals on the same side of the switch.
17. Install the switchbox (item 22) on the machine where it will be easily accessible during snowblower operation using three #10 x 1/2" self-drilling screws (item 24). Avoid placing the switch box where wires are already installed as they could be damaged.

**NOTE:** The fourth self-drilling screw will be used later.

18. Remove the lockwasher and insert the switch (item 19) inside the switchbox. Set in place with the nut. Install the plastic cap (item 21) on the other switchbox hole if required and place the rubber cap (item 18) on the switch. Bring the wires toward the snowblower.
19. Remove the valve's (Fig. 1 or 2, item 4) connection case "A" (Fig. 3, item 3) by completely removing the screw on the front of the case (Fig. 3, item 4) and remove the bottom plug (Fig. 3, item 5). Using a small screwdriver, push slowly on the connection block (Fig. 3, item 6) by inserting the screwdriver in the plug hole (Fig. 3, item 5) to remove it from the case (Fig. 3, item 3). Insert a white 360" wire (Fig. 1 or 2, item 16) in the hole identified as #1 (Fig. 3, item 1) on the connection block (detail, item 6) and a black 9" wire (Fig. 1 or 2, item 14) in the hole identified #2 (Fig. 3, item 2) and run the wires through the bottom plug (Fig.3, follow the ghost lines).
20. Put the block case (Fig.3, item 6) back in the case (Fig.3, item 3) so the wires point down to avoid water infiltrations (see Figure 3). Put the case back on the valve (Fig. 1 or 2, item 4) and secure with the screw (Fig.3, item 4). Put the bottom plug back in place (detail, item 5).

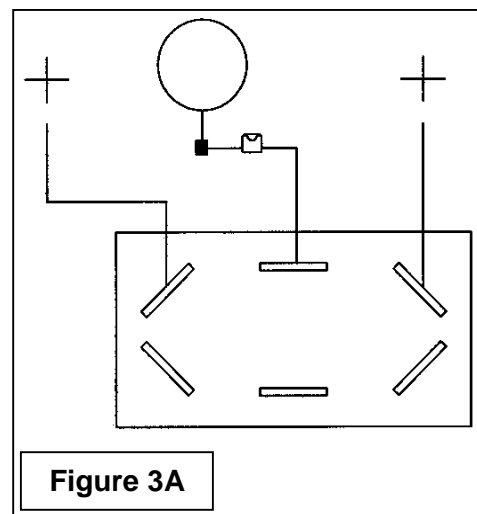
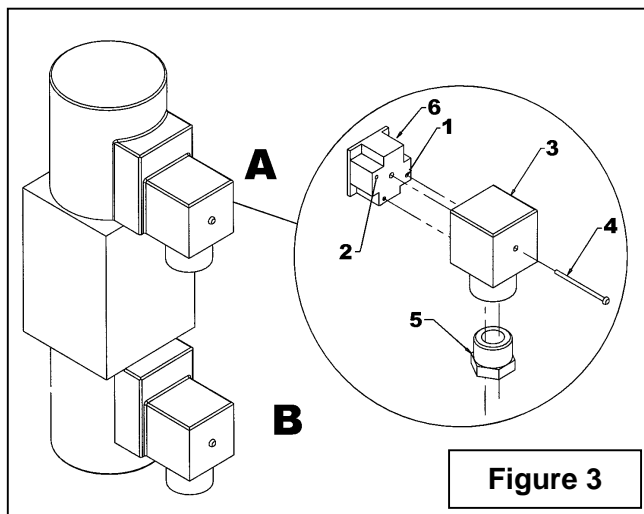



## INSTRUCTION SHEET

## 8184 - HYDRAULIC DEFLECTOR

21. Remove connection case "B" and insert a 360" white wire (Fig.1 or 2, item 16) in the hole identified #1 (Fig.3, item 1) of the connection block (Fig.3, item 6). Insert the 9" black wire (Fig.1 or 2, item 14) of case "A" as well as the 360" black wire (Fig. 1 or 2, item 15) in the hole identified #2 (Fig. 3, item 2). Run the wires through the case plug (Fig.3, follow the ghost lines).
22. Put the case back on the valve (Fig. 1 or 2, item 4) and secure with the screw (Fig.3, item 4). Put the bottom plug back in place (detail, item 5).
23. Bring the 360" black wire (Fig. 1 or 2, item 15) to the switchbox (item 19) through the same path used to bring the white wires (item 16) from the tractor to the snowblower and fasten the eye terminal to the switchbox using the fourth #10 x 1/2" self-drilling screw (Fig. 1 or 2, item 24).
24. Connect the fuse wire (Fig. 1 or 2, item 20) to the tractor's ignition switch wire using the tap connector (Fig. 1 or 2, item 17).
25. Place a loom (item 23) around all wires to protect them.
26. Secure the loom with tie wraps making sure to leave it loose enough to compensate for the movement of the tractor's articulations.
27. Fasten the two cylinder hydraulic hoses together with tie wraps and check to ensure they do not get stuck in the chute's rotation mechanism.

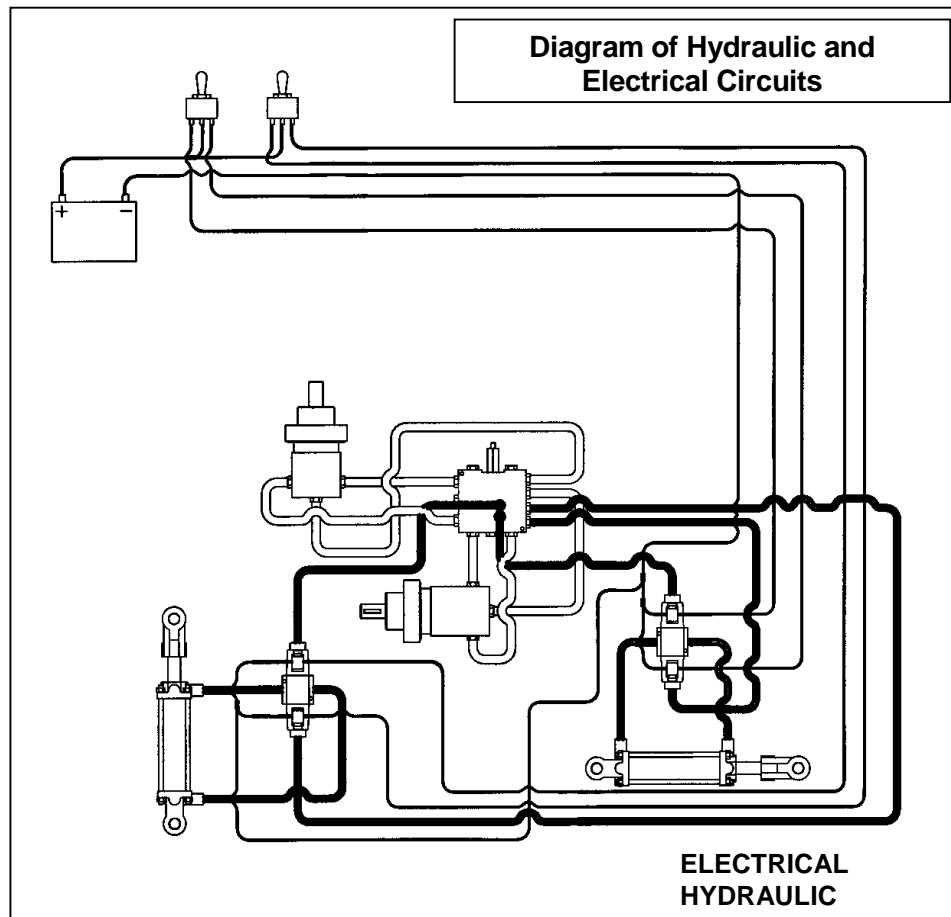



# INSTRUCTION SHEET

# 8184 - HYDRAULIC DEFLECTOR

## HYDRAULIC DEFLECTOR - 8184

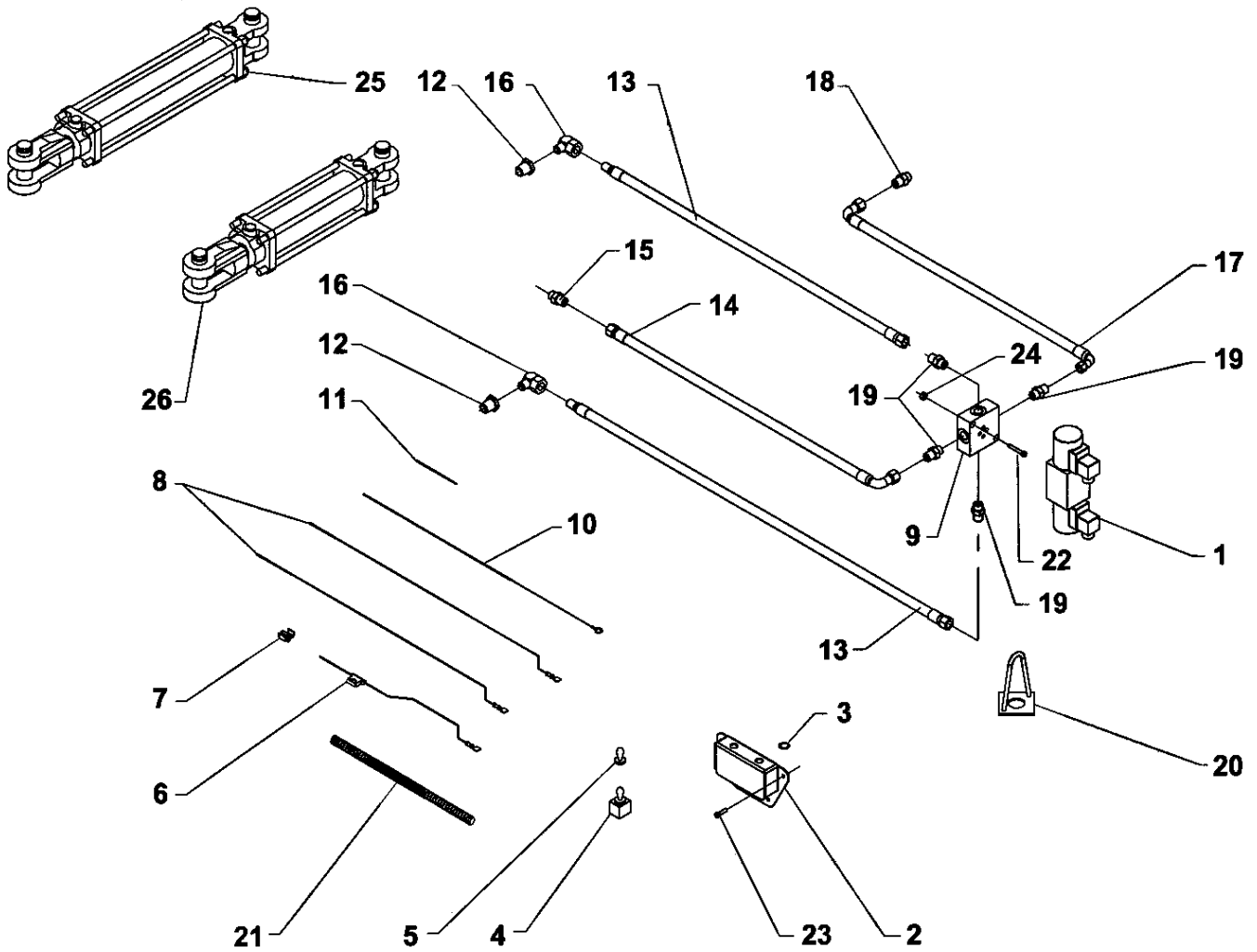



# INSTRUCTION SHEET

# 8184 - HYDRAULIC DEFLECTOR

## HYDRAULIC DEFLECTOR - 8184

REF.	DESCRIPTION	QTY	PART #
1	Electrio-hydraulic valve	1	3900027
2	Switch box	1	666048
3	Plastic cap	1	662530
4	Switch 6 blades	1	4000027
5	Rubber cap	1	658666
6	Fuse wire 72"	1	666065
7	Tap connector	1	656665
8	Ground wire 360" (white)	2	666066
9	Electro-hydraulic valve manifold	1	3900028
10	Negative wire 360" (black)	1	666067
11	Negative wire 9"	1	666068
12	Adapter 1/2"NPT male x 3/8"NPT female	2	654551
13	Hose 1/4" x 83", 9/16"JIC swivel fem. x 1/4" swivel male	2	3700011
14	Hose 1/4" x 37", 9/16"JIC swivel fem. short bend 90 x 9/16"JIC swivel fem.	1	3700016
15	Flow restrictor 5/64"	1	666069
16	Elbow 90°, 3/8"NPT male x 1/4"NPT swivel female	2	654438
17	Hose 1/4" x 45", 7/16"JIC swivel fem. short bend 90 x 9/16"JIC swivel fem. short bend 90	1	3700017
18	Connector 7/16" male ORB x 7/16" male JIC	1	664271
19	Connector 9/16" male ORB x 9/16" male JIC	4	661544
20	Hose support	1	666072
21	Loom	1	666053
22	Socket head capscrew #10-24 x 1 1/4", PTD	2	O/L
23	Self-drilling screw #10-24 x 1/2", PTD	4	O/L
24	Nylon insert locknut #10-24 PTD	2	O/L
<b>Hydraulic cylinder 8150 for H76</b>			
25	Cylinder 3" x 8"	1	654129
	Seal kit for 654129 cylinder (not shown)		664176
<b>Hydraulic cylinder 8155 for H64</b>			
26	Cylinder 2" x 6"	1	3900002
	Seal kit for 3900002 cylinder (not shown)		2600047