

# INSTRUCTION SHEET

# 8164B & BER0030 ROTATIONS BY MOTOR

## APPLICATION:

8164B - SA74 to SA104TRC installed on tractors with 12 GPM or less  
BER0030 –SA88 to SA104TRC installed on tractors with 12 GPM or more

## INSTALLATION

### Chute Rotation (Figures 1-1a)

1. **Figure 1:** Install the motor (item 1) placing the anchor plate on top (item 2) as shown on figure. Attach with four 3/8"NC x 1 1/4" (item 3) hex. bolts, lockwashers and flat washers (items 4-5). Tighten manually.
2. **Figure 1:** Install the motor gear (item 6) with the key, 8mm x 20mm bolt (item 7), lockwasher and flat washer (items 8-9). Tighten according to the "**Torque Specification Table**".
3. **Figure 1:** Insert the anchoring flat bar (item 10) between the anchor plate (item 2) and the motor support as shown on figure. Screw the 3/8"NC nuts (item 11) at maximum on the two 3/8"NC x 1 1/2" lg bolts (item 12). Install those two bolts (item 12) by screwing them in the anchoring flat bar (item 10).
4. **Figure 1a:** Adjust the distance between the chute gear and the motor gear according to the following step:
  - A. Slightly unscrew the two bolts (item 17) that hold the retaining plate.
  - B. Screw the two nuts (item 18) simultaneously until the distance between the retaining plates and the chute base is levelled.
  - C. Retighten the bolts (item 17) according to the "**Torque Specification Table**". located at the end of the manual.
  - D. Adjust the gears to a distance between 1/32" and 1/16" by screwing the two bolts (item 12). Secure with the nuts (item 11) moving them against the anchoring flat bar (item 10). Tighten the four bolts (item 3) at 30 ft-lb (41 N-M).
  - E. Run a test at low speed. If the gears have an irregular sound while testing, it means the adjustment is incorrect. Bring parts closer to each other until the sound becomes regular and even.
5. Reinstall the cover (item 13) with four 5/16" x 1" bolts (item 14), 3/8" flat washers (item 15) on the outside and 5/16" serrated flange nuts (item 16) on the inside. Tighten according to the "**Torque Specification Table**".

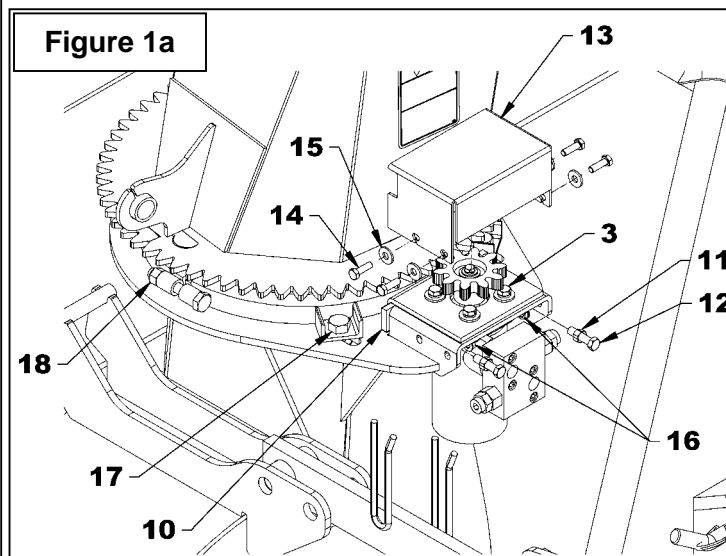
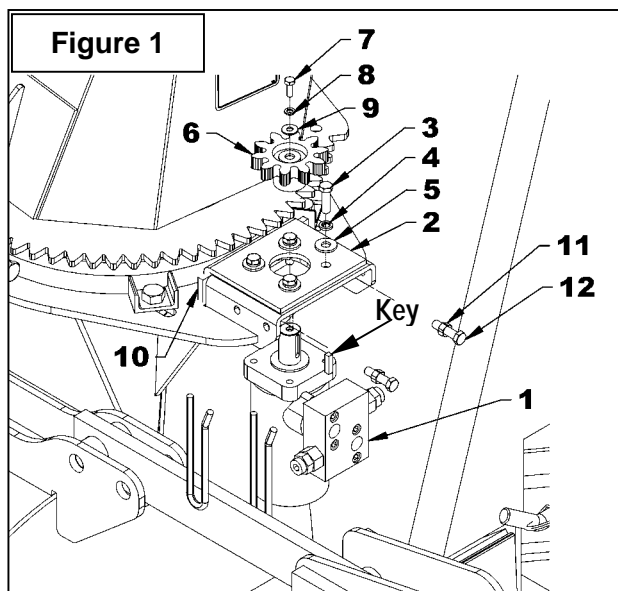

# INSTRUCTION SHEET

## 8164B & BER0030 ROTATIONS BY MOTOR

### Drum Rotation (Figures 2-7)

1. **Figure 2:** Remove the gear protector (item 1) by unscrewing the two 5/16"NC x 1" lg serrated flange bolts (item 2) and the two 5/16"NC serrated flange nuts (item 3).

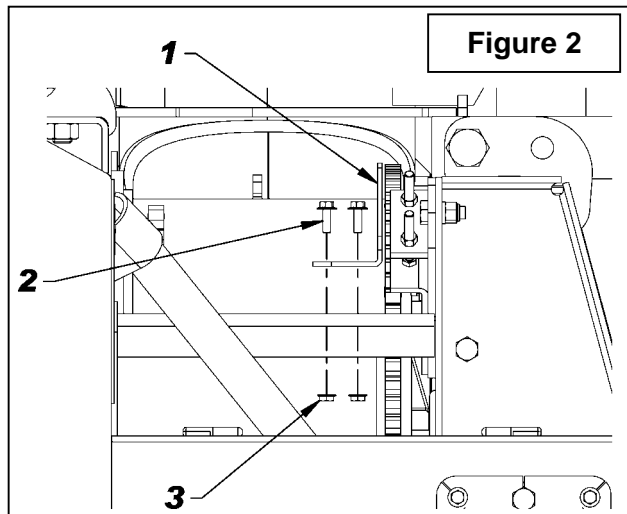

2. **Figure 3:** Remove the four 3/8"NC hex. nuts (item 1) and the four 7/16" hole flat washers (item 2) holding the motor support. This hardware will not be used to install the motor but retain the four 3/8"NC x 1 1/4" hex. bolts, the four 3/8" lockwashers and the four 7/16" hole flat washers (items 3-4-5).

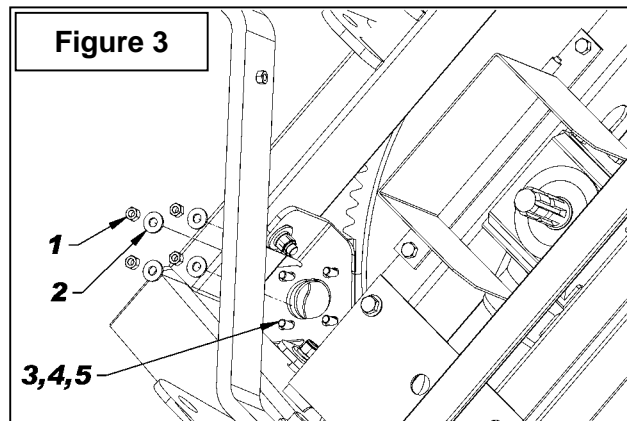

3. **Figure 4:** Attach the hydraulic motor (item 1) to the motor support (item 2) taken apart previously with the four 3/8"NC x 1 1/4" bolts, four 3/8" lockwashers and four 7/16" hole flat washers (items 3-4-5). Tighten the bolts by hand.

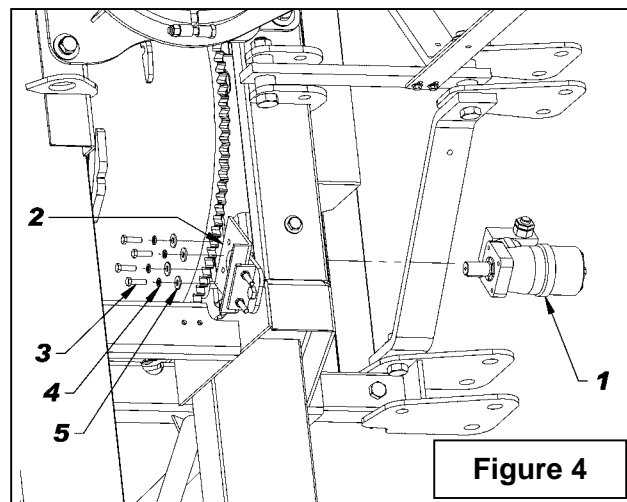

# INSTRUCTION SHEET

# 8164B & BER0030 ROTATIONS BY MOTOR

4. **Figure 5:** Place the gear (item 1) on the motor shaft aligning the gear's keyway with the key of the motor. Push the gear completely down placing the teeth between the teeth of the drum gear. If the space is not sufficient, screw in the two stopper bolts (item 5) by tightening the nuts (item 6). Secure the gear in place with a .8mm x 1.25 x 20mm lg hex. bolt (item 2), a 5/16" lockwasher (item 3) and a 3/8" hole flat washer (item 4). Torque the bolt at 20 ft-lb (27 N-M).
5. **Figure 6:** Adjust the gear by pushing it towards the drum. Push one tooth of the motor gear against one tooth of the drum gear leaving a 1/16" clearance on the other side as illustrated. Tighten the four motor bolts firmly.

## IMPORTANT

6. **Figure 7:** Attach the hydraulic hoses (not included) to the motor and connect to the tractor. Turn the motor gear, one turn at a time, checking the 1/16" distance at every turn. If the distance is smaller than 1/16", readjust. This distance must be checked over the whole drum gear. When the gear is properly adjusted, secure the motor with the two stopper bolts (**Fig. 5**, item 5) by placing the two bolt heads against the motor support (**Fig. 4**, item 2). Tighten the screws (**Fig. 5**, item 6) very firmly.
7. **Figure 4:** Remove one of the four 3/8"NC x 1 1/4" bolts (item 3) holding the motor, apply Loctite® 243 on the bolt threads and tighten at 33 ft-lb (45 N-M). Repeat the same procedure with the other three bolts.
8. **Figure 2:** Reinstall the gear protector (item 1)

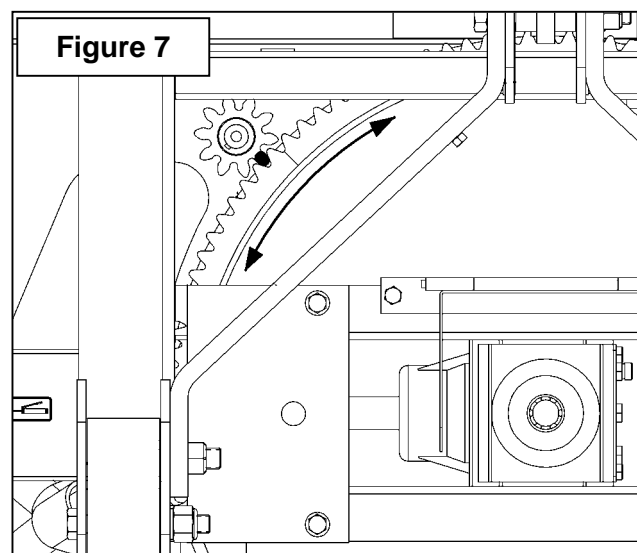
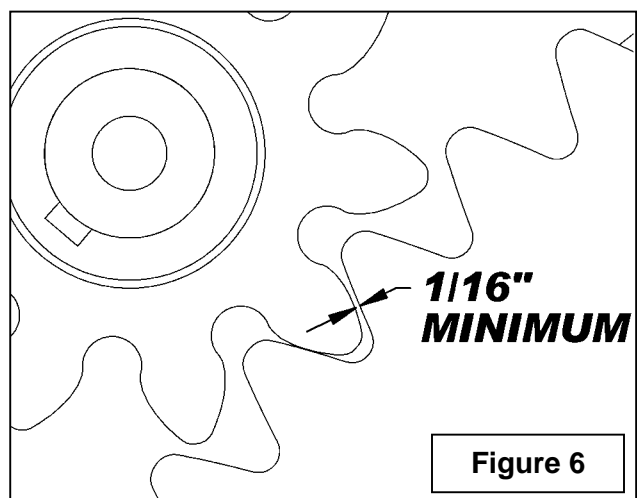
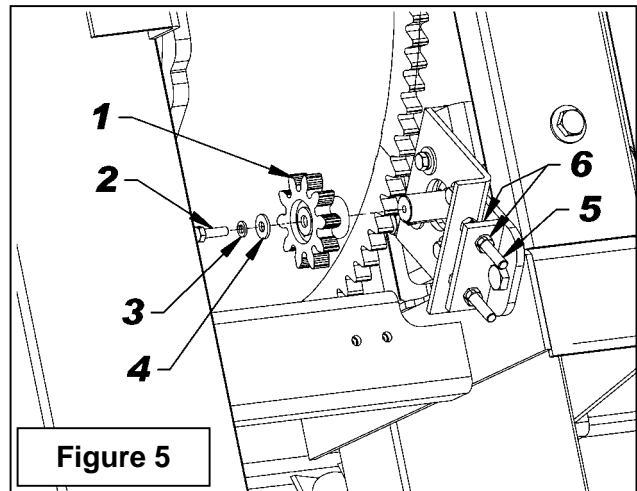

# INSTRUCTION SHEET

# 8164B & BER0030 ROTATIONS BY MOTOR

## PARTS

REF.	DESCRIPTION	QTY	PART#
1	Hydraulic motor M+S for 8164B	1	3900016
	Seal kit	1	3900077
OR	Hydraulic motor EAGLE with safety valve for 8164B	1	3910012
	Seal kit	1	3910013
OR	Hydraulic motor EAGLE with safety valve for BER0030	1	3910016
	Seal kit	1	3910013
2	Safety valve	1	3900076
3	Motor gear	1	665930
4	Key 1/4" x 1/4" x 3/4" lg	1	654686
5	Allen socket head capscrew 5/16" NC x 1 1/2" lg PTD	4	0800031
6	Bolt hex. 8mm x 20mm gr.8.8 PTD	1	O/L
7	Lockwasher 5/16" PTD	1	O/L
8	Flat washer 5/16" (3/8" hole) PTD	1	O/L

