



## INSTRUCTION SHEET

## 8164B - ROTATION BY MOTOR

**APPLICATION:** SA88, SA92-L, SA92 and SA98 snowblowers

### ***Installation (Figure 1-1a)***

- Figure 1:** Install the motor (item 1) placing the anchor plate on top (item 2) as shown on figure. Attach with four 3/8"NC x 1 1/4" (item 3) hex. bolts, lockwashers and flat washers (items 4-5). Tighten manually.
- Figure 1:** Install the motor gear (item 6) with the key, 1/4" x 3/4" bolt (item 7), lockwasher and flat washer (items 8-9). Tighten according to the "***Torque Specification Table***".
- Figure 1:** Insert the anchoring flat bar (item 10) between the anchor plate (item 2) and the motor support as shown on figure. Screw the 3/8"NC nuts (item 11) at maximum on the two 3/8"NC x 1 1/2" lg bolts (item 12). Install those two bolts (item 12) by screwing them in the anchoring flat bar (item 10).
- Figure 1a:** Adjust the distance between the chute gear and the motor gear according to the following step:
  - Slightly unscrew the two bolts (item 17) that hold the retaining plate.
  - Screw the two nuts (item 18) simultaneously until the distance between the retaining plates and the chute base is leveled.
  - Retighten the bolts (item 17) according to the "***Torque Specification Table***". located at the end of the manual.
  - Adjust the gears to a distance between 1/32" and 1/16" by screwing the two bolts (item 12). Secure with the nuts (item 11) moving them against the anchoring flat bar (item 10). Tighten the four bolts (item 3) at 30 lbs-ft (41 N-M).
  - Run a test at low speed. If the gears have an irregular sound while testing, it means the adjustment is incorrect. Bring parts closer to each other until the sound becomes regular and even.
- Reinstall the cover (item 13) with four 5/16" x 1" bolts (item 14), 3/8" flat washers (item 15) on the outside and 5/16" serrated flange nuts (item 16) on the inside. Tighten according to the "***Torque Specification Table***".

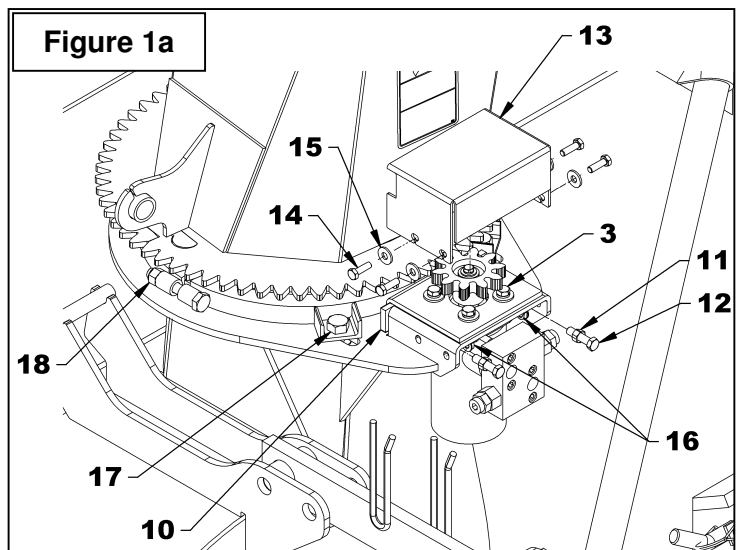
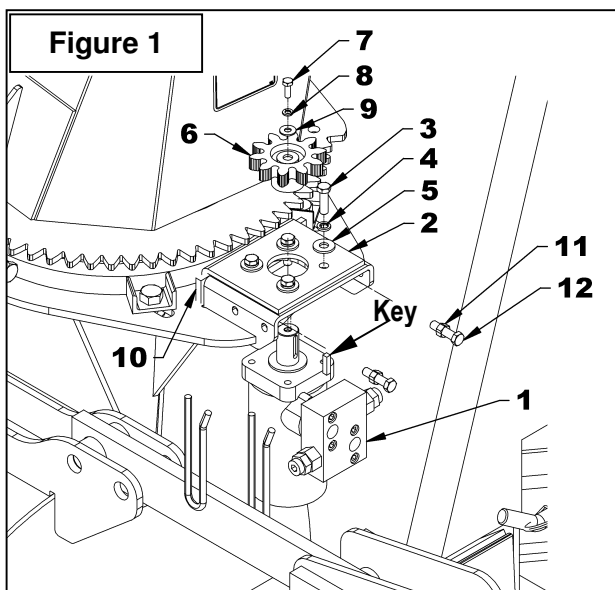



# INSTRUCTION SHEET

# 8164B - ROTATION BY MOTOR

## PARTS

REF.	DESCRIPTION	QTY	PART#
1	Hydraulic motor M+S	1	3900016
	Seal kit	1	3900077
	Hydraulic motor EAGLE	1	3910012
	Seal kit	1	3910013
2	Safety valve	1	3900076
3	Motor gear	1	665930
4	Key 1/4" x 1/4" x 3/4" lg	1	654686
5	Allen socket head capscrew 5/16" NC x 1 1/2" lg PTD	4	0800031
6	Bolt hex. 1/4" NC x 3/4" gr.5 PTD	1	O/L
7	Lockwasher 1/4" PTD	1	O/L
8	Flat washer 1/4" (5/16" hole) PTD	1	O/L

