



## INSTRUCTION SHEET

## 8164B - ROTATION BY MOTOR

**APPLICATION:** SA88, SA92-L, SA92 and SA98 snowblowers

### Installation (Figure 1-1a)

- Figure 1:** Install the motor (item 1) placing the anchor plate above (item 2) as shown on figure. Attach with four 3/8"NC x 1" lg (item 3) hex. bolts and lockwashers. Tighten manually.
- Figure 1:** Install the motor gear with the key, bolt (item 4), flat washer and lockwasher. Tighten according to the Torque Specification Table.
- Figure 1:** Insert the anchoring flat bar (item 5) between the anchor plate (item 2) and the motor support as shown on figure. Screw the 3/8NC nuts (item 6) at maximum on the two 3/8"NC x 1 1/2" lg bolts (item 7). Install those two bolts (item 7) by screwing them in the anchoring flat bar (item 5).
- Figure 1a:** Adjust the distance between the chute gear and the motor gear according to the following step:
  - Slightly unscrew the two bolts (item 8) that hold the retaining plate.
  - Screw the two nuts (item 9) simultaneously until the distance between the retaining plates and the chute base is leveled.
  - Retighten the bolts (item 8) according to the Torque Specification Table located at the end of the manual.
  - Adjust the gears with a distance of 1/32" to 1/16" by screwing the two bolts (item 7). Secure with the nuts (item 6) moving them against the anchoring flat bar (item 5). Tighten the four bolts (item 3) according to the Torque Specification Table located at the end of the manual.
  - Run a test at low speed. If the gears make irregular sound while testing, it means the adjustment is incorrect. Bring parts closer to each other until the sound becomes regular and even.
- Reinstall the cover (item 10) with four 5/16" x 1" bolts, 3/8" flat washers (items 11-12) on the outside and four 5/16" lockwashers and nuts (items 13-14) on the inside. Tighten according to the Torque Specification Table.

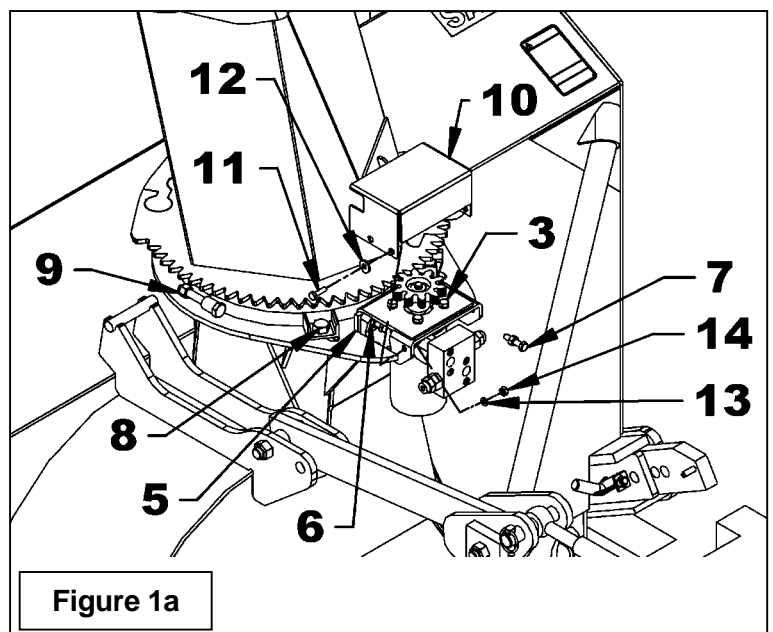
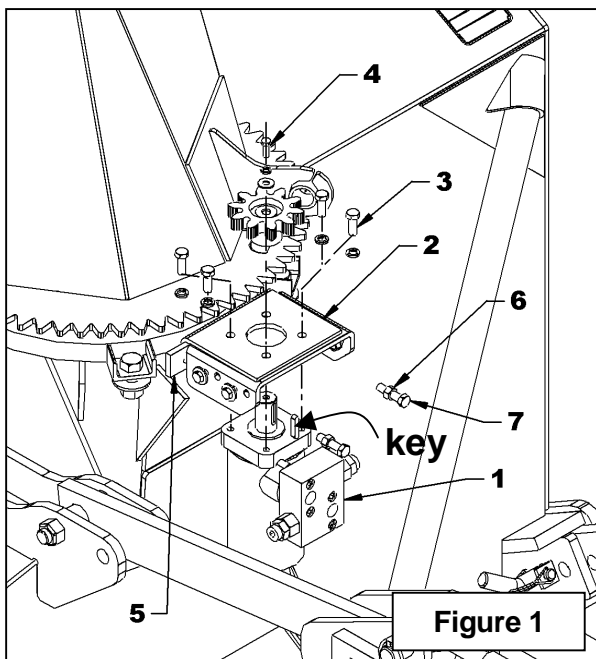



# INSTRUCTION SHEET

# 8164B - ROTATION BY MOTOR

## PARTS

| REF. | DESCRIPTION   | QTY | PART#   |
|------|---|-----|---------|
| 1    | Hydraulic motor                                     | 1   | 3900016 |
|      | Seal kit  | 1   | 3900077 |
| 2    | Safety valve  | 1   | 3900076 |
| 3    | Motor gear  | 1   | 665930  |
| 4    | Key 1/4" x 1/4" x 3/4" lg                           | 1   | 654686  |
| 5    | Allen socket head capscrew 5/16" NC x 1 1/2" lg PTD | 4   | 0800031 |
| 6    | Bolt hex. 1/4" NC x 3/4" gr.5 PTD                   | 1   | O/L     |
| 7    | Lockwasher 1/4" PTD                                 | 1   | O/L     |
| 8    | Flat washer 1/4" (5/16" hole) PTD                   | 1   | O/L     |

