



INSTRUCTION SHEET

8152 DRIFT CUTTERS

INSTALLATION

1. Remove the 1/2" NC x 1 1/2" bolt (item 5) from the motor support (item 17) and the 5/16" NC x 1 1/4" bolt (item 4) from the hose guard (item 16).
2. Position the left drift cutter (item 2) next to the holes in the housing and reinstall the 1/2" NC x 1 1/2" bolt (item 5), 9/16" flatwasher (item 8), 1/2" lockwasher (item 9) and 1/2" NC nut (item 10) in the lower hole.
3. In the middle hole, reinstall the 5/16" NC x 1 1/4" bolt (item 4), 5/16" flatwasher (item 11), 5/16" lockwasher (item 12) and 5/16" NC nut (item 13).
4. In the upper hole, insert a 3/8" NC x 1" bolt (item 3), 3/8" lockwasher (item 14) and 3/8" NC nut (item 15).
5. Position the right drift cutter (item 1) next to the holes in the housing and secure in place using the 3/8" NC x 1" upper bolt (item 3), 3/8" lockwasher (item 15) and 3/8" NC nut (item 14).
6. Make sure that the right drift cutter is aligned with the housing and drill a 11/32" hole in the housing, using the right drift cutter's (item 1) middle hole as a template. Insert a 5/16" NC x 1" bolt (item 6), 5/16" lockwasher (item 12) and 5/16" NC nut (item 13).
7. Drill a 17/32" hole in the housing using the lower hole in the right drift cutter item 1). Insert a 1/2" NC x 1 1/4" bolt (item 7), 1/2" lockwasher (item 9) and 1/2" NC nut (item 10).

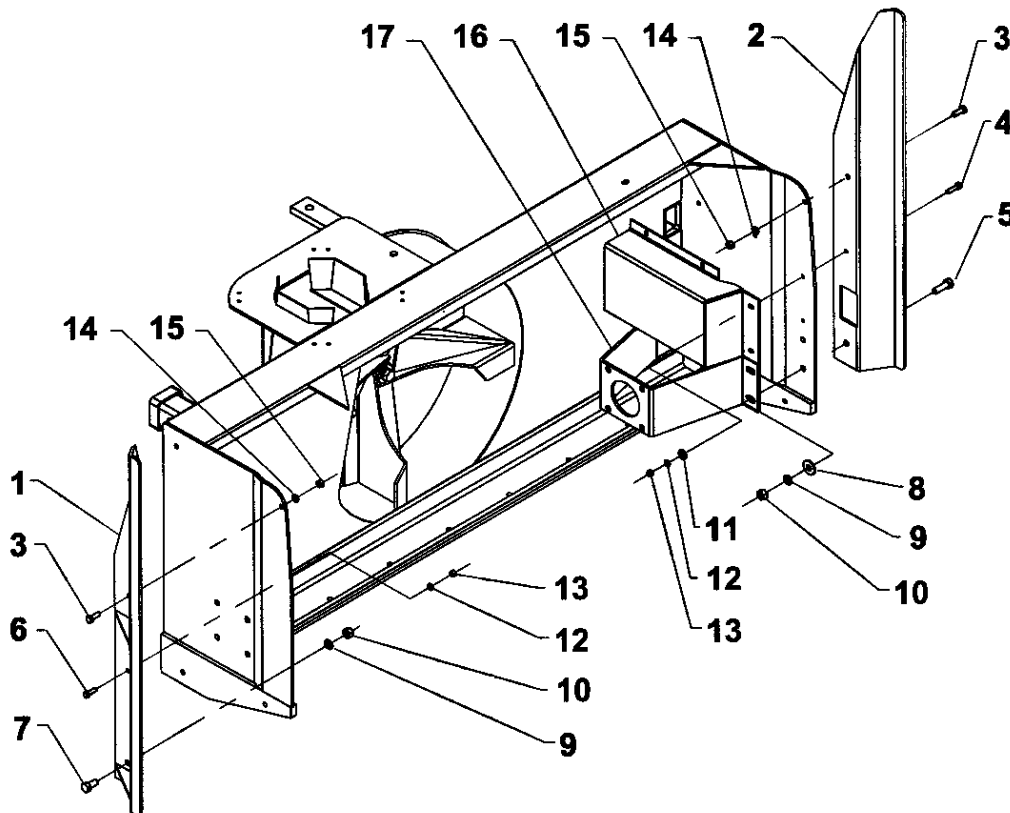



INSTRUCTION SHEET

8152 DRIFT CUTTERS

PARTS

REF.	DESCRIPTION	QTY	PART #
1	Left drift cutter	1	665874
2	Right drift cutter	1	665879
3	Bolt hex. 3/8"NC x 1", PTD, gr.5	2	O/L
4	Bolt hex. 5/16"NC x 1", PTD, gr.5	1	O/L
5	Bolt hex 1/2"NC x 1 1/4", PTD, gr.5	1	O/L
6	Lockwasher 3/8", PTD	2	O/L
7	Lockwasher 5/16", PTD	1	O/L
8	Lockwasher 1/2", PTD	1	O/L
9	Nut hex. 3/8"NC, PTD	2	O/L
10	Nut hex. 5/16"NC, PTD	1	O/L
11	Nut hex. 1/2"NC, PTD	1	O/L

