



Second Auger Conversion Kit (Option)
(Figure 8)

1. Remove the front guard and loosen the idler sprocket. Remove the lower auger chain and the bolts on each side of the lower auger (item 4) bearings (item 2). Remove the lower auger from the snowblower.
2. Install the new sprockets (item 3) on both augers using four 3/8" NC x 1 1/4" bolts for the upper auger (item 5) and four 3/8" NC x 1 1/2" bolts for the lower auger (item 4), with lockwashers and nuts (items 6-7-8). Tighten according to the Torque Specification Table located in your snowblower's manual.
3. Reinstall lower (item 4) and upper augers (item 5) with the supplied bearings (item 9) and 1/2" x 1 1/2" bolts, lockwashers and nuts (items 10-11-12). Do not tighten setscrews on the bearings now.
4. Install idler sprocket (item 13) on chain idler support (item 14) as shown, using a 5/8" NC x 2 1/2" carriage bolt, 11/16" flatwashers and 5/8"NC nylon insert locknut (items 15-16-17). Assemble support inside snowblower in the pre-bored holes, using two 3/8" NC x 1 1/4" bolts, lockwashers and nuts (items 18-19-20).
5. Install the chain as shown and assemble the connecting link by placing the opening opposite the direction of the chain rotation (see Figure 8a). Align the auger's sprockets with the idler sprocket and tighten securely the setscrews on the auger bearings to stabilize the augers.
6. Install the new chain guard (item 21) supplied with the optional upper auger, using three 3/8"NC x 1" bolts and nylon insert locknuts (items 22-23). Reinstall the lower auger chain and the front guard.

Figure 8a

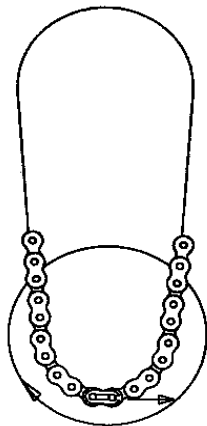
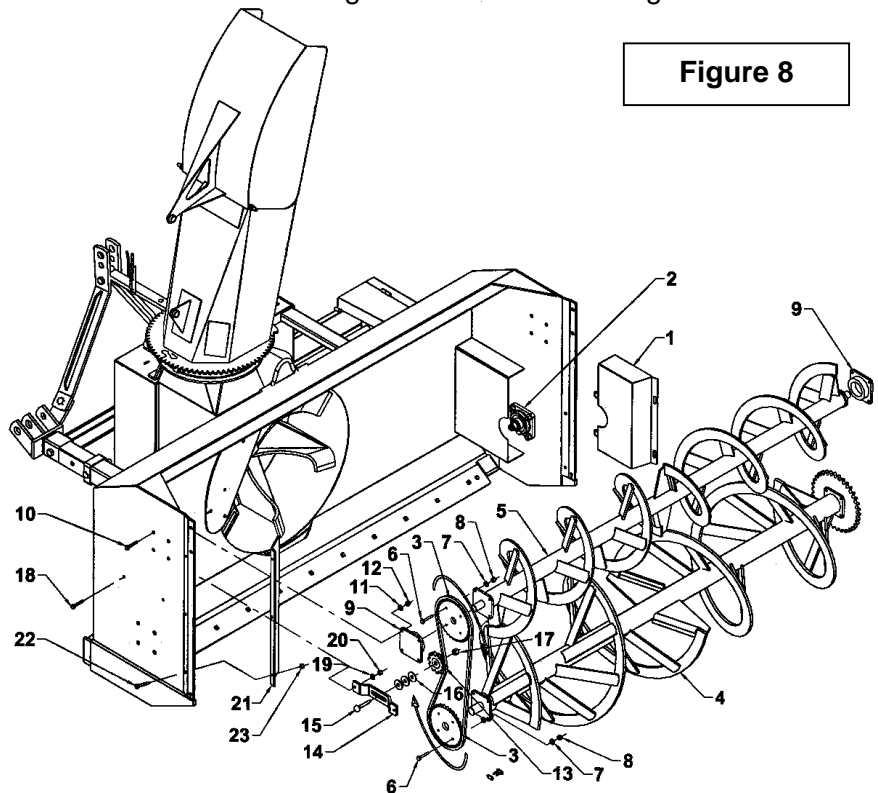

Figure 8





INSTRUCTION SHEET

8049 & 8050 – SECOND AUGER KIT

SECOND AUGER CONVERSION KIT (OPTION)

REF.	DESCRIPTION	QTY.	PART #	PART #	PART #
			SA92-SA92TRC (8049)	SA98-SA98TRC (8050)	SA104TRC (9464)
1	Upper auger	1	666450	666451	666452
2	Chain guard	1	662443	662443	662443
3	Chain idler support	1	655782	655782	655782
4	Bearing hole 1/4" dia., 4 holes	2	4300001	4300001	4300001
5	Chain #60 x 90 links & connecting link	1	662447	662447	662447
6	Sprocket #60A32 hole 1 1/4" dia.	2	654167	654167	654167
7	Idler sprocket CA60	1	654010	654010	654010
8	Bolt hex. 3/8" NC x 1 1/2" gr.5 PTD	8	O/L	O/L	O/L
9	Lockwasher 3/8" PTD	10	O/L	O/L	O/L
10	Nut hex. 3/8" NC PTD	10	O/L	O/L	O/L
11	Bolt hex. 1/2" NC x 1 1/2" gr.5 PTD	8	O/L	O/L	O/L
12	Lockwasher 1/2" PTD	8	O/L	O/L	O/L
13	Nut hex. 1/2" NC PTD	8	O/L	O/L	O/L
14	Carriage bolt 5/8" NC x 2 1/2" gr.5 PTD	1	O/L	O/L	O/L
15	Flatwasher hole 11/16" dia. PTD	2	O/L	O/L	O/L
16	Nylon insert locknut 5/8" NC PTD	1	O/L	O/L	O/L
17	Bolt hex. 3/8" NC x 1" gr.5 PTD	3	O/L	O/L	O/L
18	Nylon insert locknut 3/8" NC PTD	3	O/L	O/L	O/L
19	Sprocket #60A32 hole 1 1/2" dia.	1	662444	662444	662444
20	Connecting link #60	1	654839	654839	654839
21	Bolt hex. 3/8" NC x 1 1/4" gr.5 PTD	2	O/L	O/L	O/L

