



INSTRUCTION SHEET

8044 – HYDRAULIC NOZZLE ROTATION

INSTALLATION

GENERAL PREPARATION:

1. Remove the air blast nozzle (fig.4, item 1) from the debris blower. Discard bolts and nuts.
2. Remove the deflector (fig.4, item 2) from the air blast nozzle. Keep bolts and nuts on hands.
3. Using the paper drilling pattern, drill two 9/32" dia holes on the side of the air blast nozzle where there is no round hole.
4. On the air blast nozzle side of the debris blower, remove the two 3/8" NC x 6 1/2" hex bolts (fig.3, items 2-3) and two 3/8" NC flange nuts (fig.3, item 4) located above and below the tubing (fig.3, item 1). Keep these bolts and nuts on hands.

AIR BLAST NOZZLE ASSEMBLY (Fig.4)

1. Secure the #40 roller chain assembly (item 4) to the rotating ring (item 5) with 1/4" NC x 1" hex bolts (item 6), 5/16" flatwashers (item 7) and 1/4" NC. stover nut (item 8). Tighten securely.
2. Secure the rotating ring to the air blast nozzle with 1/4" NC x 5/8" hex. bolt (item 9), and 1/4" NC flange nut (item 10). Tighten securely.
3. Secure the deflector to the air blast nozzle with bolts and nuts already kept on hands. Tighten securely.

4. Secure the air blast nozzle assembly (with the nylon ring) to the debris blower. Place the air blast nozzle assembly under the air outlet. Place the 4 rotation spacers (item 12) under the air outlet. Place both retaining plates (item 13) under the rotation spacers. Place the rotation bracket (item 14) under the retaining plates. Secure with 1/4" NC x 1 1/4" hex bolts (item 15), 1/4" NC x 1" hex bolts (item 16), 1/4" lockwashers (item 17) and 1/4" NC hex nuts (item 18). Tighten loosely.

ROTATION BRACKET ASSEMBLY:

1. Insert a 7/16" flatwasher on each bolt kept on hand and attach the rotation bracket to the debris blower using these bolts and nuts kept on hands. The rotation bracket should go over the intake cover (item 3), with the slot covering the tubing (fig.3, item 1).
2. Tighten securely all the bolts and nuts

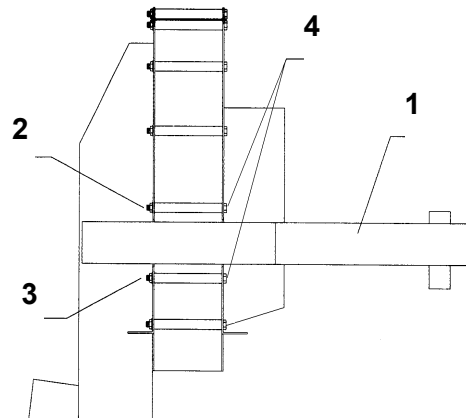

Figure 3



INSTRUCTION SHEET

8044 – HYDRAULIC NOZZLE ROTATION

HYDRAULIC MOTOR ASSEMBLY (Fig.4)

1. Tighten securely connectors (item 20) to hydraulic motor (item 21). Using thread sealant, tighten securely connectors and 1/4" x 28" hoses (item 22).
2. Insert the 1/8" x 1/8" x 1" keystone (item 23) in the keyway of the hydraulic motor.
3. Slide the sprocket (item 24) over the shaft of the hydraulic motor. Tighten loosely the 1/4" NC x 1/4" allen socket setscrews (item 25) of the sprocket.
4. Place the hydraulic motor assembly on the fixation plate (item 28) and secure with the three M6 x 1.0 x 10mm allen flathead setscrews (item 29). Then, place the hydraulic motor over the rotation bracket (item 14), passing the sprocket (item 24) through the oblong hole. Mesh the sprocket in the #40 roller chain assembly. Secure the hydraulic motor assembly in place with two 3/8" NC x 1 1/4" hex bolts (item 26), four 7/16" flatwashers (item 19), two 3/8" lockwashers (item 27) and two 3/8" NC hex nuts (item 11). Tighten securely.
5. Place the sprocket so that the #40 roller chain assembly are leveled together. Tighten securely the 1/4" NC x 1/4" allen socket setscrews (item 25) of the sprocket.

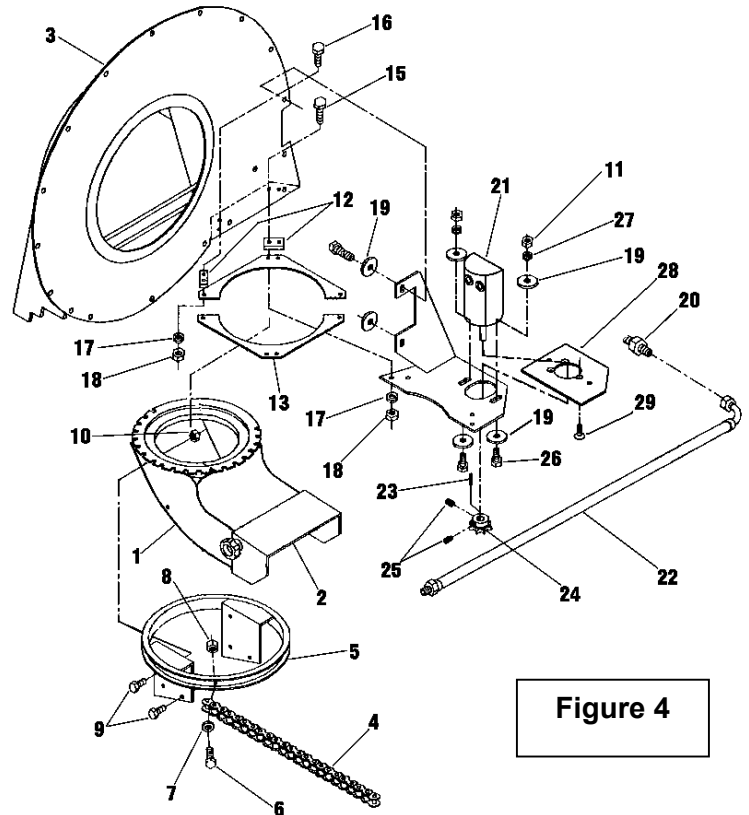

Figure 4

LUBRICATION

Lubricate the #40 roller chain with a good chain lubricant once every 16 hours of operation.



INSTRUCTION SHEET

8044 – HYDRAULIC NOZZLE ROTATION

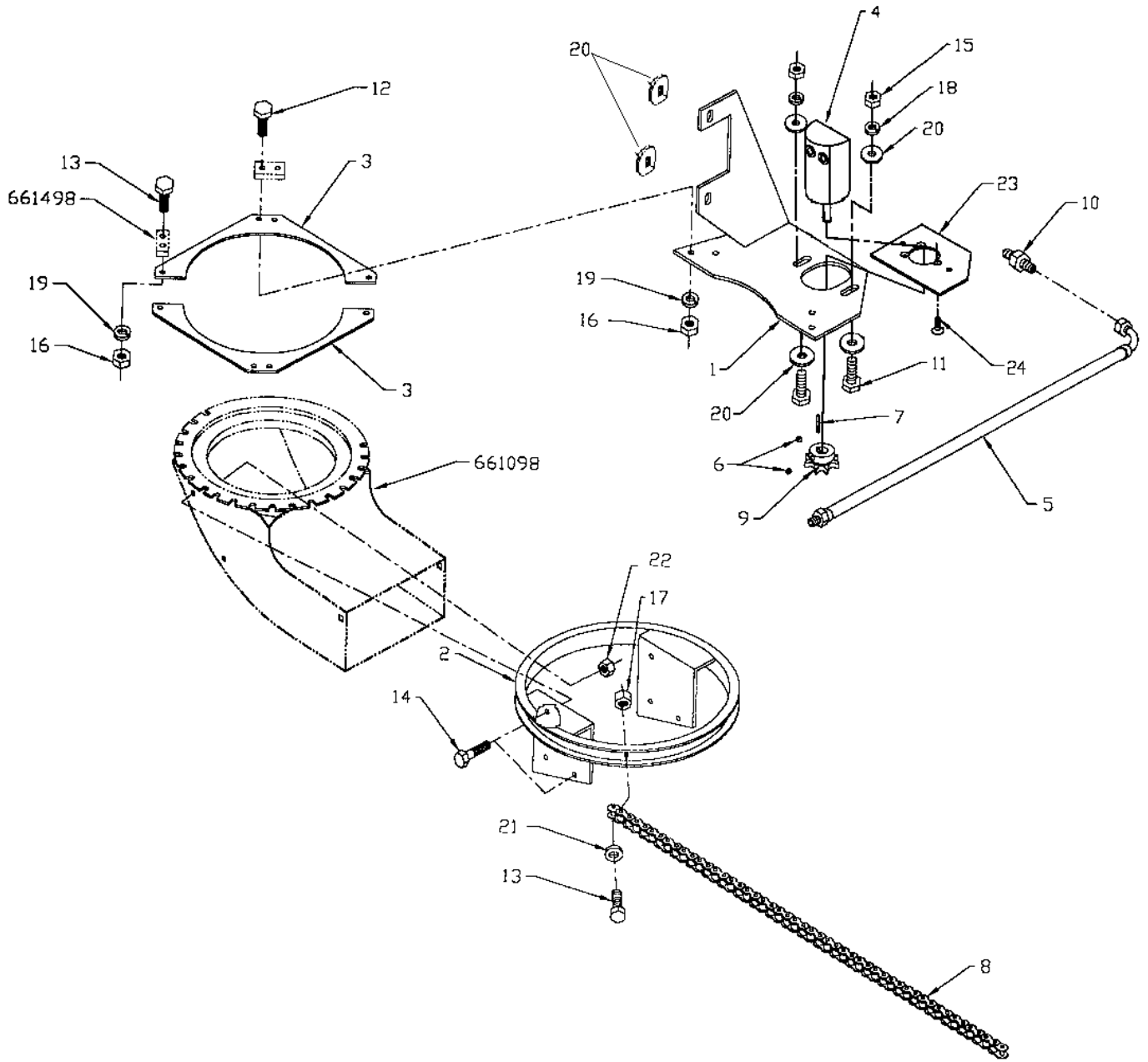

**INSTRUCTION SHEET****8044 – HYDRAULIC NOZZLE ROTATION****HYDRAULIC NOZZLE ROTATION KIT - 8044 (OPTION)**

REF.	DESCRIPTION	QTY	PART #
1	Rotation bracket CW	1	664220
2	Rotating ring CW	1	664223
3	Retaining plate	2	664243
4	Hydraulic motor	1	665305
	Seal kit		665454
5	Hydraulic hose 1/4" x 28"	2	660324
6	Allen socket setscrew 1/4" NC x 1/4"	2	O/L
7	Keysteel 1/8" x 1/8" x 1"	1	664233
8	Roller chain assembly #40	1	664235
9	Sprocket #H40B10	1	665411
10	Connector	2	661544
11	Hex bolt 3/8" NC x 1 1/4"; PTD	2	O/L
12	Hex bolt 1/4" NC x 1 1/4"; PTD	4	O/L
13	Hex bolt 1/4" NC x 1"; PTD	6	O/L
14	Hex bolt 1/4" NC x 5/8"; PTD	4	O/L
15	Hex nut 3/8" NC; PTD	2	O/L
16	Hex nut 1/4" NC; PTD	8	O/L
17	Hex nut 1/4" NC (stover); PTD	2	O/L
18	Lockwasher 3/8"; PTD	2	O/L
19	Lockwasher 1/4"; PTD	8	O/L
20	Flatwasher 7/16"; PTD	6	O/L
21	Flatwasher 5/16"; PTD	2	O/L
22	Flange nut 1/4" NC PTD	4	O/L
23	Fixation plate	1	665464
24	Allen flathead setscrews M6 x 1.0 x 10mm	3	O/L

O/L = Obtain Locally



INSTRUCTION SHEET

8044 – HYDRAULIC NOZZLE ROTATION