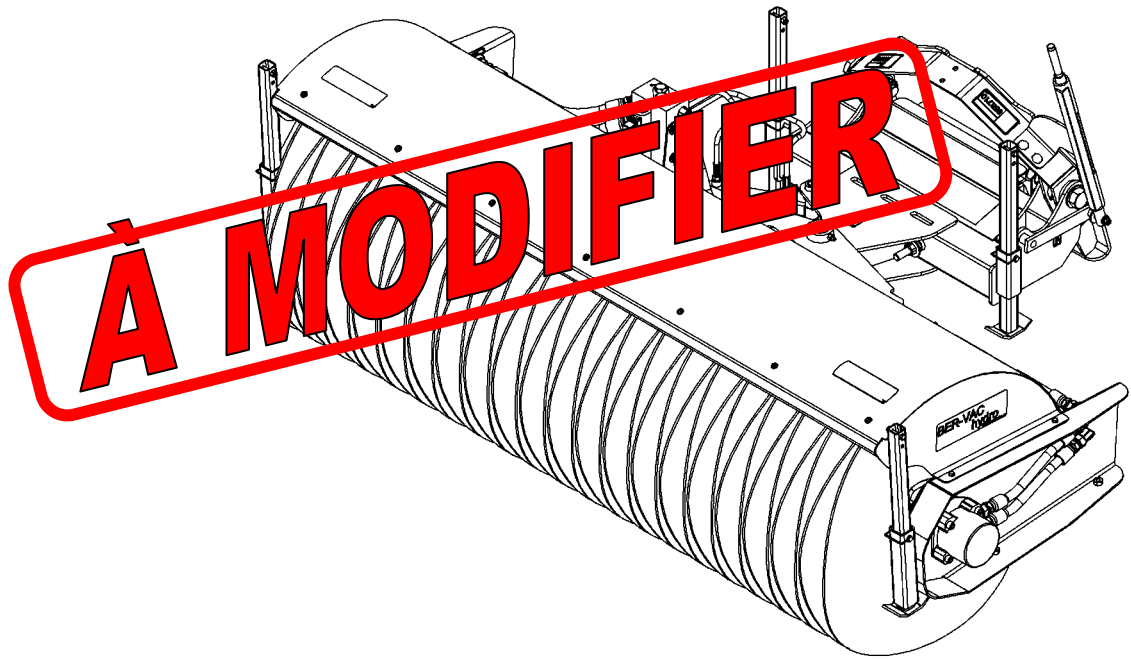


**RAD**



# **OPERATOR'S AND PARTS MANUAL**

**60", 72"& 84" HYDRAULIC ROTARY BROOMS  
MODELS HB6032, HB6032X, HB7232, HB7232X,  
HB8432 & HB8432XX**

SERIAL NO. SHT05135 AND UP

OM 0372BR32-A  
09/07





---

# TABLE DES MATIÈRES

---

INTRODUCTION – TO THE PURCHASER .....	3
SAFETY PRECAUTIONS .....	4
Before Operation.....	4
Notice.....	5
Rotary Broom .....	5
Before Operation .....	5
Rotary Broom Operation .....	6
The Tractor .....	8
General Information.....	8
Operating the Tractor.....	8
During Operation .....	9
Roll-Over Protective Structure "ROPS" (If Equipped).....	9
Additional Safety Equipment.....	9
Maintenance .....	10
Transporting.....	11
ASSEMBLY .....	12
Rotary Broom Assembly .....	12
Installation of Universal Hitch 8153 .....	12
Installation of Universal Hitch 8161 .....	12
Installation of 3 Point Hitch BER0006.....	13
Installation of Hydraulic Hoses .....	14
Installation of the Electrical Wiring – Skid steer and Front Loader .....	15
Installation of the Electrical Wiring – 3 Point Hitch.....	19
Installation of the Broom on a Skid Steer .....	22
Installation of the Broom on a 3 Point Hitch.....	24
Installation of the Broom on a Quick Hitch.....	24
Removing Broom from Skid Steer .....	25
Removing Broom from 3 Point Hitch .....	25
Removing Broom from Quick Hitch .....	25

---

# TABLE DES MATIÈRES

---

OPERATION.....	26
General Preparation.....	26
Operation .....	26
Rotary Broom Controls .....	26
Hydraulic Angling Adjustment .....	26
Ground Pressure Adjustment.....	27
General Sweeping .....	29
Lawn Dethatching & Lawn Raking .....	30
Snow Removal .....	30
Troubleshooting .....	30
MAINTENANCE.....	31
Maintenance .....	31
Brush Replacement .....	32
Compression Springs.....	33
Storage .....	34
Lubrication .....	35
Periodic Checks .....	35
DIAGRAMS .....	36
SPECIFICATIONS.....	37
PARTS.....	38
Introduction.....	38
Decals .....	39
Rotary Broom - Hitch .....	40
Rotary Broom - Housing .....	42
Rotary Broom – Hydraulic Hoses.....	44
Brush Assembly.....	46
Hydraulic Motors.....	48
Hydraulic Block.....	49
Electro-Hydraulic Valve.....	50
Electrical Wiring .....	51
AVAILABLE OPTIONS .....	52
WARRANTY .....	53
TORQUE SPECIFICATION TABLE .....	54

---

# INTRODUCTION

---

## TO THE PURCHASER

All products are designed to give safe, dependable service if they are operated and maintained according to instructions. **Read and understand this manual before operation.**

This manual has been prepared to assist the owner and operators in the safe operation and suitable maintenance of the rotary broom. The information is applicable to products at the time of manufacture and does not include modifications made afterwards.

Read and understand this operator's manual before attempting to put equipment into service. Familiarize yourself with the operating instructions and all the safety recommendations contained in this manual and those labeled on the equipment and on the tractor. Follow the safety recommendations and make sure that those with whom you work follow them.

### **Illustrations**

The illustrations may not necessarily reproduce the full detail and the exact shape of the parts or depict the actual models, but are intended for reference only.

### **Direction Reference**

All references to right and left, forward or rearward, are from the operator's seat, facing the steering wheel.

*To assist your dealer in handling your needs, please record hereafter the model number and serial number of your rotary broom and tractor. It is also advisable to supply them to your insurance company. It will be helpful in the event that rotary broom or tractor is lost or stolen.*

## **TRACTOR**

## **ROTARY BROOM**

MODEL: \_\_\_\_\_

SERIAL NUMBER: \_\_\_\_\_

DATE OF PURCHASE: \_\_\_\_\_

DEALER NAME: \_\_\_\_\_

---




# SAFETY PRECAUTIONS

---



## SAFETY FIRST

This symbol, the industry's "Safety Alert Symbol", is used throughout this manual and on labels on the machine itself to warn of the possibility of personal injury. Read these instructions carefully. It is essential that you read the instructions and safety regulations before you attempt to assemble or use this rotary broom.

-  **DANGER :** Indicates an immediate hazardous situation which, if not avoided, will result in death or serious injury.
-  **WARNING :** Indicates a potentially hazardous situation which, if not avoided, could result in death or serious injury.
-  **CAUTION :** Indicates a potentially hazardous situation which, if not avoided, may result in minor or moderate injury.
- IMPORTANT :** Indicates that rotary broom or property damage could result if instructions are not followed.
- NOTE :** Gives helpful information.

All products are designed to give safe, dependable service if they are operated and maintained according to instructions. **Read and understand this manual before operation.** It is the owner's responsibility to be certain anyone operating this product reads this manual, and all other applicable manuals, to become familiar with this rotary broom and all safety precautions. Failure to do so could result in serious personal injury or rotary broom damage. If you have any questions, consult your dealer.

## **BEFORE OPERATION**

### **Children**

Tragic accidents can occur if the operator is not alert to the presence of children. Children are generally attracted to machines and the work being done. Never assume children will remain where you last saw them.

1. Keep children out of the operating area and under the watchful eye of another responsible adult.
2. Be alert and turn machine off if children enter the work area.
3. Before and when backing, look behind for small children.
4. Never carry children while operating the machine. They may fall off and be seriously injured or interfere with the safe operation of the machine.
5. Never allow children to play on the machine or rotary broom even when they are turned off.
6. Never allow children to operate the machine even under adult supervision.
7. Use extra care when approaching blind corners, shrubs, trees, or other obstructions that might hide children from sight.

---

# SAFETY PRECAUTIONS - continued

---

## **NOTICE**

A safe operator is the best assurance against accidents. All operators, no matter how experienced they may be, should read this operator's manual and all other related manuals before attempting to operate the rotary broom. Please read the following section and pay particular attention to all safety recommendations contained in this manual and those labeled on the rotary broom and on the tractor.

## **ROTARY BROOM**

### **Before Operation**

1. Read and understand this operator's manual and tractor operator's manual. Know how to operate all controls and how to stop the unit and disengage the controls quickly.
2. Never wear loose, torn, or bulky clothing around the tractor, the rotary broom. It may catch on moving parts or controls, causing injury.
3. Before and during seasons, thoroughly inspect the area where the rotary broom is to be used and remove all objects that may be thrown or cause damage to the rotary broom.
4. Set transmission to neutral and disengage clutch, if equipped, before starting the engine.
5. Do not operate rotary broom in wintertime without wearing adequate winter garments. Always wear protective clothing.
6. Never attempt to make any adjustments while engine is running. Read this manual carefully to acquaint yourself with the rotary broom as well as the tractor operator's manual. Working with unfamiliar rotary broom can lead to accidents. Be thoroughly familiar with the controls and proper use of the rotary broom.
7. Keep all safety guards in place and verify hardware for proper tightening.
8. Check for moving parts excessive wear regularly. Replace worn parts with genuine parts.
9. Replace all missing, illegible, or damaged safety and warning decals. See list of decals in operator's manual.
10. Do not modify or alter this rotary broom or any of its components, or any rotary broom function without first consulting your dealer.
11. Keep safety decals clean of dirt and grime.
12. Make sure the tractor is counterweighted as recommended by your dealer. Weights provide the necessary balance to improve stability, traction and steering.

---

## SAFETY PRECAUTIONS - continued

---

### **Rotary Broom Operation**

1. Before leaving the tractor unattended, take all possible precautions. Park the tractor/rotary broom on level ground, place the transmission in neutral, set the parking brake, disengage the PTO, lower the rotary broom to the ground, place all levers including auxiliary control levers in neutral, shut off the engine and remove the ignition key.
2. Before starting the tractor/ rotary broom, inspect and clean every rotating part.
3. Prior to operation, clear work area of all objects that can be picked up and thrown. Mark all curbs, pipes, etc. that cannot be moved.
4. Be sure the PTO switch/lever is in OFF position before starting engine.
5. Exercise extreme caution when operating on or crossing a gravel drive, walks, or roads. Stay alert for hidden hazards or traffic.
6. Do not carry passengers.
7. Keep clear of all rotating parts. Do not put hands or feet under, or into rotary broom with engine running. Be especially observant of the rotary broom areas of discharge, intake or all other mechanical motions.
8. Park the tractor/rotary broom on level ground, place the transmission in neutral, set the parking brake, disengage the PTO, lower the rotary broom to the ground, place all control levers in neutral, shut off the engine, remove the ignition key and allow the rotating parts to stop BEFORE making any repairs, adjustments or inspections.
9. If the rotary broom starts to vibrate abnormally, disengage the PTO, stop the engine immediately and check for cause. Excessive vibration is generally a sign of a problem.
10. Do not run the engine indoors except when starting engine and transporting attachment in or out of building. Carbon monoxide gas is colorless, odorless and deadly.
11. Do not attempt to operate on steep slopes. If operating on slopes is necessary, exercise extreme caution when changing direction.
12. Never operate rotary broom without guards, and other safety protective devices in place. All tractor and rotary broom shields and covers must be correctly installed at all times. When necessary to remove these, they must be reinstalled immediately.
13. Never operate rotary broom near glass enclosures, automobiles, window wells, embankments, etc., without proper adjustment of discharge angle.
14. Never operate rotary broom at high transport speeds on a slippery surface.
15. Use extra caution when backing up.
16. Disengage power to rotary broom when transporting or when not in use.
17. Never operate the rotary broom without good visibility and lighting.
18. Prolonged exposure to loud noise can cause impairment or loss of hearing. Wear a suitable hearing protective device such as earmuffs or earplugs to protect against objectionable or uncomfortable noises.
19. Never allow anyone near the work area.
20. Securely connect rotary broom drive shaft. Check that all tractor and rotary broom drivelines are in good working order. Rotary broom drive shaft coupler must securely lock to and be retained by annular groove on tractor drive shaft.

---

## **SAFETY PRECAUTIONS - continued**

---

- 21.** Never allow anyone to operate the rotary broom until they have read the manual completely and are thoroughly familiar with basic tractor and rotary broom operation.
- 22.** Make sure the tractor is counterweighted as recommended by your dealer. Weights provide the necessary balance to improve stability, traction and steering.
- 23.** Always make sure all rotary broom components are properly installed and securely fastened BEFORE operation.
- 24.** Make sure nobody is in the working area of the rotary broom. The debris that can be thrown could cause serious personal injuries.
- 25.** Adjust spring tension so that the rotary broom head weighs approximately 50 lbs when the front is lifted.

---

# SAFETY PRECAUTIONS - continued

---

## **THE TRACTOR**

### **General Information**

1. Read the operator's manual carefully before using tractor. Lack of operating knowledge can lead to accidents.
2. Do not permit anyone but the operator to ride on the tractor. There is no safe place for passengers.

### **Operating the Tractor**

1. Never run the tractor engine in a closed building without adequate ventilation, as the exhaust fumes are hazardous.
2. Adopt safe driving: If the tractor is equipped with independent Right/Left brake pedals, keep the brake pedals latched together at all times unless independent braking is required. Never use independent braking during transport.
3. Always drive at a safe speed relative to local conditions and ensure that your speed is low enough for an emergency stop to be safe and secure.
4. Reduce speed prior to turns to avoid the risk of overturning. Keep speed to a minimum.
5. Always keep the tractor in gear to provide engine braking when going downhill. Do not coast.
6. Never allow an open flame near the fuel tank or battery.
7. Make sure the PTO shield is installed when using the rotary broom and always replace the PTO shield if damaged.
8. Park the tractor/rotary broom on level ground, place the transmission in neutral, set the parking brake, disengage the PTO, lower the rotary broom to the ground, place all levers including auxiliary control levers in neutral, shut off the engine and remove the ignition key BEFORE leaving the tractor.
9. Never park the tractor on a steep slope.
10. Do not attempt to operate on steep slopes. Avoid sudden uphill turns on steep slopes.
11. Handle fuel with care, as it is highly flammable.
12. Use approved fuel container.
13. Never add fuel to a running engine or a hot engine.
14. Fill fuel tank outdoors with extreme care. Never fill fuel tank indoors. Replace fuel cap securely and wipe up spilled fuel.
15. Never attempt to start the engine and/or engage rotary broom drive while standing beside the tractor.
16. Always start the engine from the operator's seat with all the transmission lever(s) and rotary broom drive lever in neutral.
17. DO NOT bypass the safety system by shorting across the terminals of the starter motor to start the engine. This may cause the tractor to move suddenly.
18. If the safety start system does not work, consult your dealer immediately.

---

## **SAFETY PRECAUTIONS - continued**

---

### **During Operation**

1. Do not allow passengers on the tractor/rotary broom at any time. There is no safe place for passengers on this rotary broom. The operator **MUST** sit in the tractor seat.
2. Eye and hearing protection is recommended when operating the rotary broom.
3. Operate only during daylight hours, or when the area is well lit with bright artificial light.
4. Park the tractor/rotary broom on level ground, place the transmission in neutral, set the parking brake, disengage the PTO, lower the rotary broom to the ground, place all control levers in neutral, shut off the engine and remove the ignition key **BEFORE** leaving the operator's seat.
5. Inspect the rotary broom after striking any foreign object to assure that all rotary broom parts are secure and not damaged.
6. Be especially observant of the operating area and terrain. Watch for holes, rocks, or other hidden hazards. **ALWAYS** inspect the area prior to operating rotary broom.
7. **DO NOT** operate rotary broom near the edge of drop-offs or banks.
8. **DO NOT** operate rotary broom on steep slopes as overturn may result.
9. Operate up and down (not across) intermediate slopes. Avoid sudden starts and stops.
10. Drive tractor backwards up steeper slopes with rotary broom off. Then operate as you travel down the slope.
11. Slow down before you change directions on any slope.
12. Make sure the tractor is counterweighted as recommended by your dealer. Weights provide the necessary balance to improve stability, traction and steering.
13. Never stand alongside of the rotary broom while the engine is running.

### **Roll-Over Protective Structure "ROPS" (If Equipped)**

1. **DO NOT** weld, drill or alter the ROPS. Damaged ROPS must not be straightened or used. If damage does occur, consult your dealer.
2. If the ROPS is lowered or removed from the tractor for any reason, it must be erected and/or refitted immediately. Original bolts or equivalent replacements must be used and tightened to the correct torque.
3. The manufacturer does not recommend usage of tractor with ROPS removed.
4. If a fold-down ROPS is used, the ROPS can be folded down for storage, but it must be pinned in the upright position prior to operation.
5. Seat belt usage: With ROPS installed on the tractor it is imperative that the seat belt be installed, used and correctly adjusted, at all times. **DO NOT** use a seat belt if operating without ROPS.

### **Additional Safety Equipment**

A fire extinguisher and first aid kit should be kept readily accessible.

---

# SAFETY PRECAUTIONS - continued

---

## **MAINTENANCE**

### **ALWAYS USE GENUINE PARTS WHEN REPLACEMENT PARTS ARE REQUIRED**

1. Keep the tractor and rotary broom properly maintained.
2. Park the tractor/rotary broom on level ground, place the transmission in neutral, set the parking brake, disengage the PTO, lower the rotary broom to the ground, place all control levers in neutral, shut off the engine and remove the ignition key and allow the rotating parts to stop BEFORE making any rotary broom adjustments.
3. To avoid injury, do not adjust, unblock the driving system, or service the rotary broom with the tractor engine running. Make sure rotating components have completely stopped before leaving the operator's seat.
4. Keep the tractor/rotary broom clean. Snow, dirt or ice build-up can lead to malfunction or personal injury from thawing and refreezing in garage.
5. Always wear eye protection when cleaning or servicing the rotary broom.
6. DO NOT service the tractor while the engine is running or hot, or if the unit is in motion. Always lower rotary broom to the ground. If necessary to service rotary broom in raised position, securely support with stands or suitable blocking before working underneath. Do not rely on hydraulically supported devices for your safety. They can settle suddenly, leak down, or be accidentally lowered.
7. Do not attempt to service machine, clear obstructions or unclog the rotary broom's driving system with the engine running. Always shut off engine and allow all motion to cease.
8. The manufacturer will not accept responsibility for fitment of unapproved parts and/or accessories and any damages as a result of their use.
9. Make sure all shields and guards are securely in place following all service, cleaning, or repair work.
10. Do not modify or alter this rotary broom or any of its components or operating functions. If you have questions concerning modifications, consult with your dealer.
11. Do not operate a rotary broom that is defective or has missing parts. Make sure that all recommended maintenance procedures are completed before operating the rotary broom.
12. Check all controls regularly and adjust where necessary. Make sure that the brakes are evenly adjusted.
13. Periodically check all nuts and bolts for tightness, especially wheel hub and rim nuts.
14. To avoid serious personal injury: Escaping hydraulic/diesel fluid under pressure can penetrate the skin causing serious injury. Do not use your hands to check for leaks. Use a piece of cardboard or paper to search for leaks.
15. Stop engine and relieve pressure before connecting or disconnecting hydraulic hoses. Tighten all connections before starting engine or pressurizing hoses.

---

## **SAFETY PRECAUTIONS - continued**

---

### **TRANSPORTING**

1. Transporting on public roadway: When driving the tractor and rotary broom on the road or highway under 25 mph, at night or during the day, use flashing amber warning lights and the Slow Moving Vehicle ("SMV") identification emblem.
2. Check local traffic codes that may apply to unit usage on public roads and highways in your area. The use of flashing amber lights is acceptable in most localities. However, some localities may prohibit their use.
3. Always disengage rotary broom drive prior to transporting unit.

# ASSEMBLY

## ROTARY BROOM ASSEMBLY

The rotary broom is pre assembled at the factory, however, parts contained in the bag and box must be installed. Use the present manual and lay out all parts for assembly. Separate bolts and nuts into various sizes. After assembly, torque all the bolts according to the Torque Specification Table enclosed at the end of the manual.

### Installation of Universal Hitch 8153 (Figure 1)

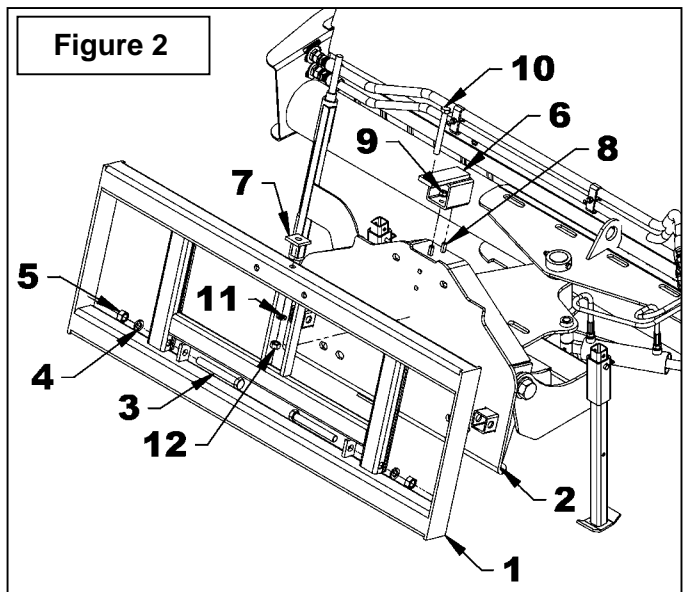
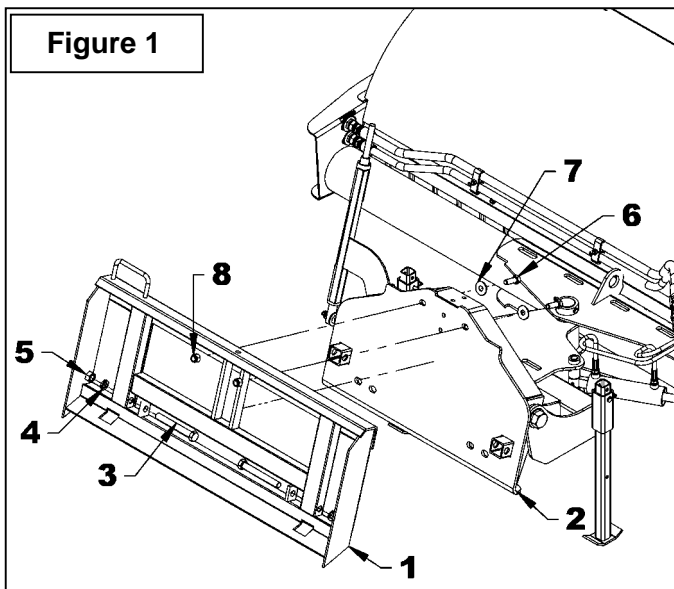
**NOTE:** Items 3, 4 and 5 are included in the universal hitch kit #8153.

1. The broom must rest on its four parking stands on a flat leveled surface.
2. Attach the universal hitch (item 1) to the rear lower section of the broom (item 2) with two  $\varnothing 3/4$ "NC x 6" hex bolts (item 3), two lockwashers (item 4) and two  $3/4$ "NC hex nuts (item 5).
3. Attach the universal hitch (item 1) to the rear upper section of the broom (item 2) with two  $5/8$ "NC x  $1\ 3/4$ " hex bolts (item 6), two  $5/8$ " flat washers (item 7) and two  $5/8$ "NC nylon insert nuts (item 8).

### Installation of Universal Hitch 8161 (Figure 2)

**NOTE:** All items except item 2 are included in the universal hitch kit #8161. The two  $5/8$ " x  $1\ 3/4$ " hex. bolts, the two  $\varnothing 5/8$ " flat washers as well as the two  $\varnothing 5/8$ "NC nylon insert nuts included with the broom are not required to the installation of the kit #8161.

1. The broom must rest on its four parking stand on a flat leveled surface.
2. Attach the universal hitch (item 1) to the rear lower section of the broom (item 2) with two  $\varnothing 3/4$ "NC x 6" hex bolts (item 3), two lockwashers (item 4) and two  $3/4$ "NC hex nuts (item 5).
3. Attach the upper hitch (item 6) to the rear upper section of the broom (item 2) with two  $1/2$ "NC x  $1\ 1/4$ " hex. bolts (item 8) and two  $1/2$ "NC serrated flange nuts (item 9).
4. Attach the upper hitch (item 6) to the universal hitch (item 1) with the spacer (item 7), a  $5/8$ "NC x 5" hex bolt (item 10), a  $5/8$ " lockwasher (item 11) and a  $5/8$ "NC nut (item 12).

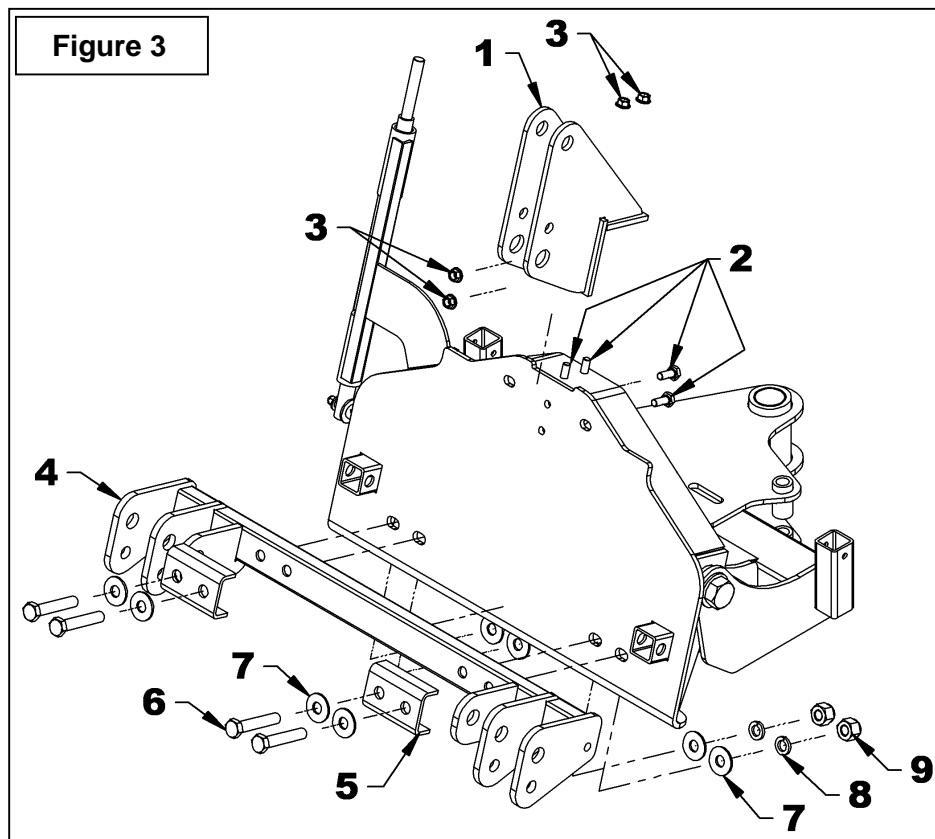


# ASSEMBLY

## Installation of 3 Point Hitch BER0006 (Figure 3)

**NOTE:** All items are included in the 3 pt hitch kit #BER0006. The two 5/8" x 1 3/4" hex. bolts, the two  $\varnothing$ 5/8" flat washers as well as the two  $\varnothing$ 5/8"NC nylon insert are not required to install the BER0006 kit.

1. The broom must rest on its four parking stand on a flat leveled surface.
2. Attach the upper support (item 1) to the rear of the broom with four 1/2"NC x 1 1/4" hex. bolts (item 2) and four 1/2"NC serrated flange nuts (item 3).
3. Attach the lower support (item 4) to the rear of the broom with the two lower support reinforcements (item 5), four  $\varnothing$ 3/4" x 4" hex. bolts (item 6), four  $\varnothing$ 3/4" flat washers (item 7), four  $\varnothing$ 3/4" flat washers (item 7), four 3/4" lockwashers (item 8) and four  $\varnothing$ 3/4"nylon insert nuts (item 9) in the order shown.



# ASSEMBLAGE

## Installation of Hydraulic Hoses

(Figure 4)

**NOTE:** The supply hoses (item 3) are not included therefore select them according to the type of vehicle to be used with the broom. It is recommended to use a 1 1/16" JIC swivel female short bend fitting and a 1 1/16" JIC male x 7/8" ORB male adaptor (665226) to connect to the hydraulic bloc.

**IMPORTANT:** For vehicles with pressure less than 2900 psi, it is recommended to use at least a 5/8" diameter SAE 100R17 hydraulic hose

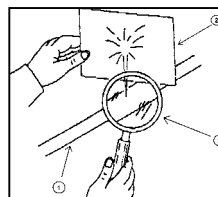
For vehicles with pressure more than 3000 psi, it is recommended to use at least a 5/8" diameter SAE 100R16 or 100R12 hydraulic hose.

1. Make sure the hydraulic hoses are long enough to allow for all the possible movements of the vehicle. Pivoting the hitch plate, raising the vehicle and angling the broom from left to right have an influence on the length of hose required. Hoses that are too short risk getting damaged which could be very dangerous for the vehicle operator.
2. Remove the hydraulic plugs on top of the hydraulic block (item 1).
3. Attach the 7/8" ORB male hydraulic adaptors (item 2 – not included) to the hydraulic bloc (item 1).
4. Attach the hoses (item 3) to the adapters (item 2). Point the hoses towards the tractor's quick couplers.
5. **For Universal Hitch 8153 only.** Secure the hydraulic hoses (item 3 – not included) to the rear plate (item 7) with the hose clamp (item 4), a  $\varnothing 3/8$ " NC x 2 1/2" hex bolt (item 5) and a  $\varnothing 3/8$ " NC nylon insert nut. Do not tighten too firmly to prevent damage to the hydraulic hoses.
6. Leave enough slack in the hoses between the hose clamp and the broom to allow for all the possible movements.
7. Install the quick couplers that correspond to those of the tractor. The hydraulic block has the mentions "P" for pressure and "T" for return hose.



**WARNING:** To avoid serious personal injury. Escaping hydraulic/diesel fluid under pressure can penetrate the skin causing serious injury.

- Do not use your hands to check for leaks. Use a piece of cardboard or paper to search for leaks.



1. Hydraulic hose
2. Cardboard
3. Magnifying glass

- Stop engine and relieve pressure before connecting or disconnecting lines.
- Tighten all connections before starting engine or pressurizing lines.

If any fluid is injected into the skin, obtain medical attention immediately or gangrene may result.

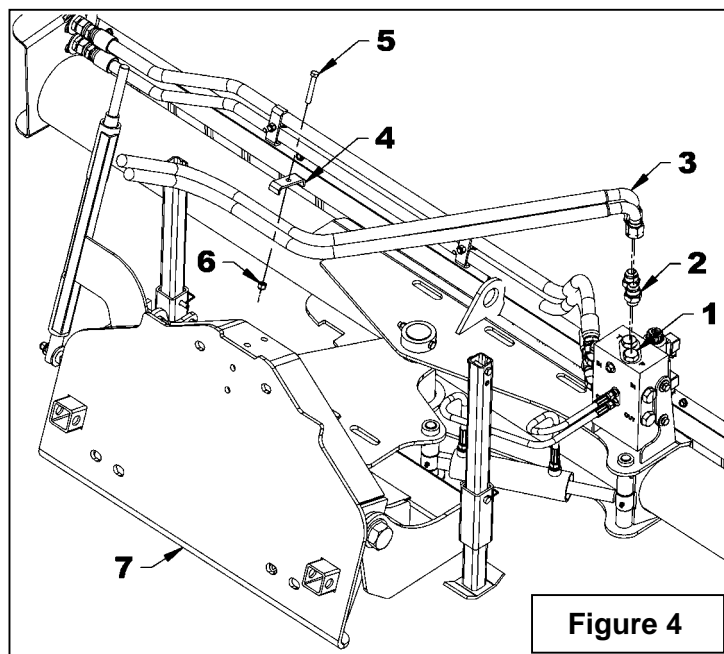


Figure 4

# ASSEMBLY

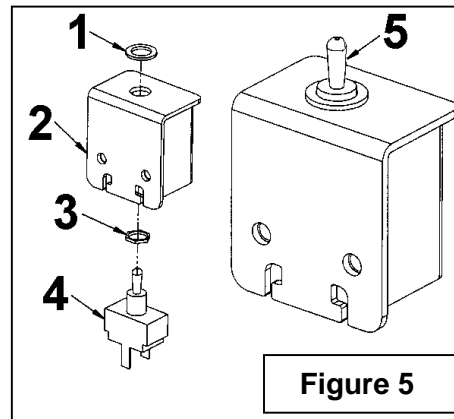
## ***Installation of the Electrical Wiring – Skid Steer and Front Loader***

***(Skid Steer - Figures 5-6-8-9)***

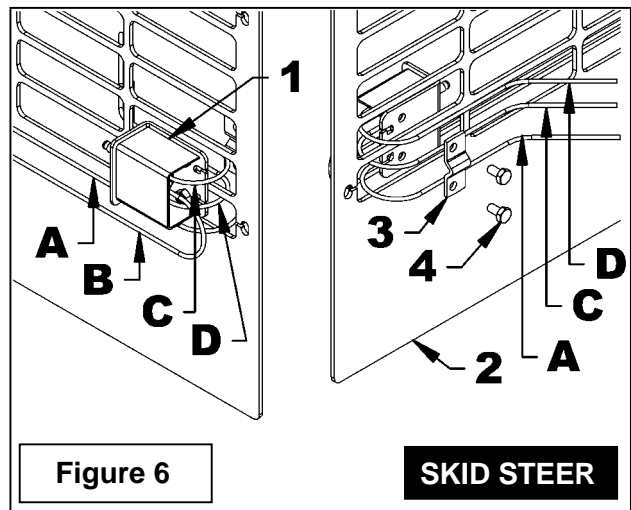
***(Front Loader - Figures 5-7-8-10)***

- Figure 5:** Insert the switch (item 4) in the switchbox (item 2) and secure together with the two nuts (items 1-3) supplied with the switch. Screw the rubber cap (item 5) on the switch.
- Figure 6:** Place the switchbox (item 1) on the vehicle's protection grill (item 2) in a comfortable working position. Fasten in place with the switchbox clamp (item 3) and two 1/4"NC x 1/2" hex bolts (item 4).
- Figure 7:** Place the switchbox (item 1) on the lever in a position that will be comfortable when the hand is on the knob and attach with the switchbox clamp (item 5), two 1/4"NC x 3/4" hex. bolts and two 1/4" lockwashers (item 4).

**NOTE:** Tighten the bolts just enough to securely fix the clamp and the switchbox on the lever. **DO NOT TIGHTEN TOO MUCH** so as not to deform the clamp.

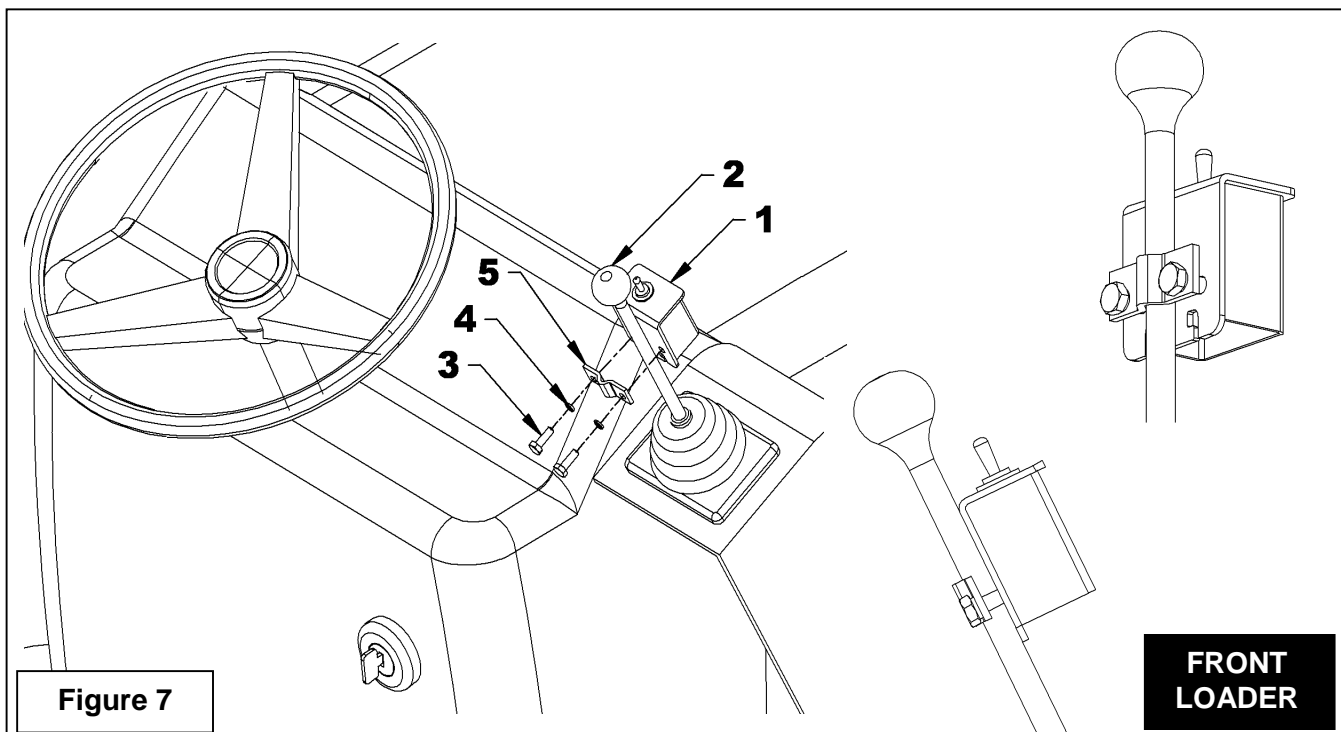


**Figure 5**



**Figure 6**

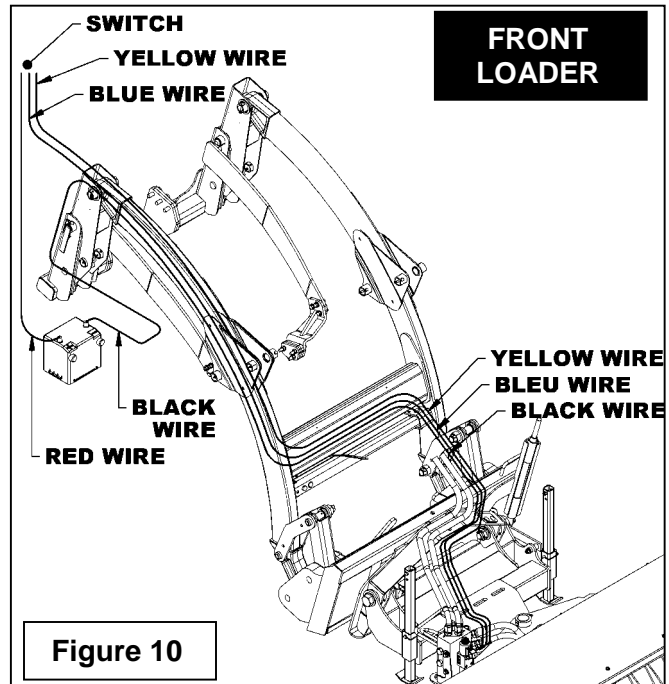
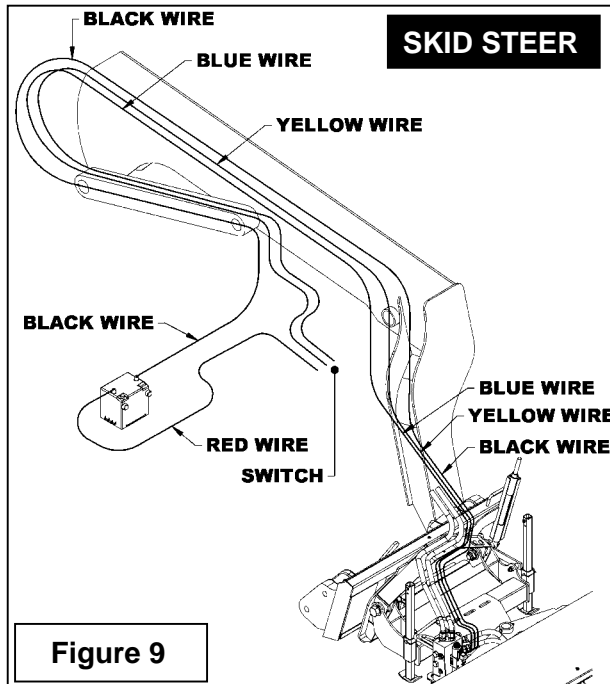
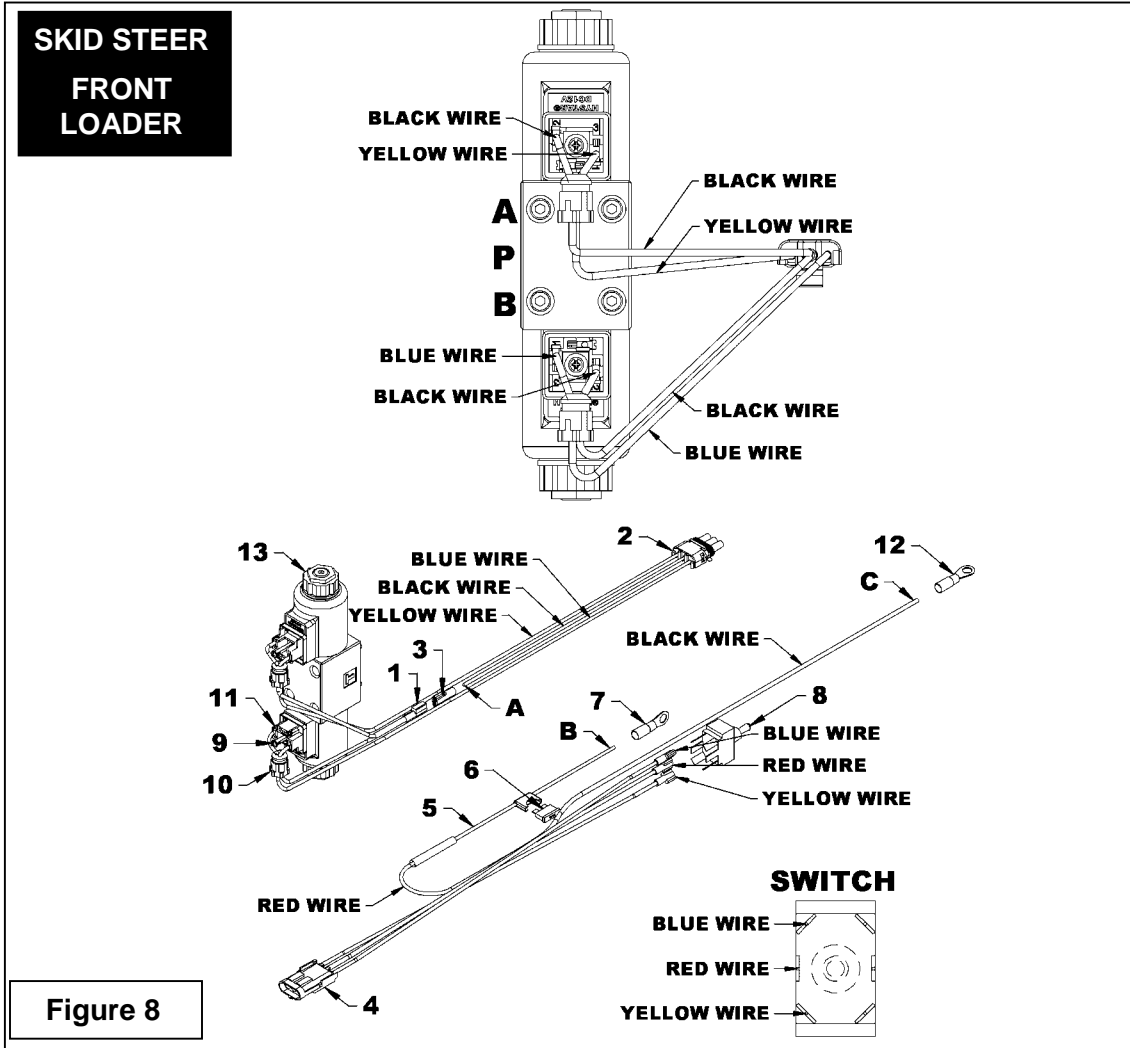
**SKID STEER**



**Figure 7**

**FRONT  
LOADER**

# ASSEMBLY



---

# ASSEMBLY

---

**NOTE:** Refer to Figure 8 unless specified otherwise.

4. Attach the 3-cavity female connector (360" wire) (item 4) close to the vehicle's quick couplers with a nylon tie wrap
5. **Figures 9 or 10:** Run the wires alongside the hydraulic hoses of the vehicle's arms before bringing them into the cab.
6. Wrap the electrical wires with the  $\varnothing 3/8$ " loom. Apply electrical tape every 12".
7. Secure the wires in place with the nylon tie wraps.
8. Connect all the wires (item 4 et 5) on the same side of the switch (item 8).
9. Connect the red battery wire (192" wire) (item 5) in the middle of the switch (item 8) on the same side as the blue and yellow wire. Run the wire through the vehicle all the way to the battery. Strip 3/8" from the wire end (item B), crimp a round terminal (item 7) then heat with a hot air gun to shrink the sheath on the wire.
10. Connect the round terminal (item 7) to the positive terminal of the battery.
11. Insert the fuse (item 6) in the battery fuse wire (item 5).
12. Connect the 3-cavity male connector (item 2) to the 3-cavity female connector (item 3) and run it in alongside the hydraulic hoses up to the electro-hydraulic valve (item 13). Leave enough slack in the wires to allow for all the possible movements of the broom and the vehicle.
13. Cut the excess wire that isn't needed.
14. Strip 3/8" from the end of the wire assembly's (item 4) black wire (item C), crimp a round terminal (item 12) then heat with a hot air gun to shrink the sheath on the wire. Install the round terminal (item 12) to make the ground.
15. Strip 1/2" from the end of the wire assembly's (item 2) black wire (item A). Fold the stripped portion in two, twist and crimp a 1/4" female terminal (item 3).
16. Strip 1/4" from the end of the wire assembly's (item 2) yellow and blue wires.
17. Remove the upper DIN connector from the electro-hydraulic valve (item 13) by removing the screw (item 9) in front of the case (item 10).
18. Take the connector apart and insert the yellow and black wires in the case (item 10).
19. Connect the yellow wire in hole #1 of the connection block (item 11) as illustrated. Strip 1/4" from the end of the wire assembly's two black wires (item 1). Connect one black wire in the #2 hole as illustrated.
20. Reinstall the connection block (item 11) in the case (item 10) taking care to place hole #3 on the same side as the case opening as illustrated so that it points toward the bottom to prevent water infiltration.
21. Reassemble the DIN connector and reinstall on the electro-hydraulic valve (item 13) with the screw previously removed (item 9).
22. Remove the lower DIN connector (item 10) from the electro-hydraulic valve (item 13) by removing the screw (item 9) in front of the case (item 10).

---

## ASSEMBLY

---

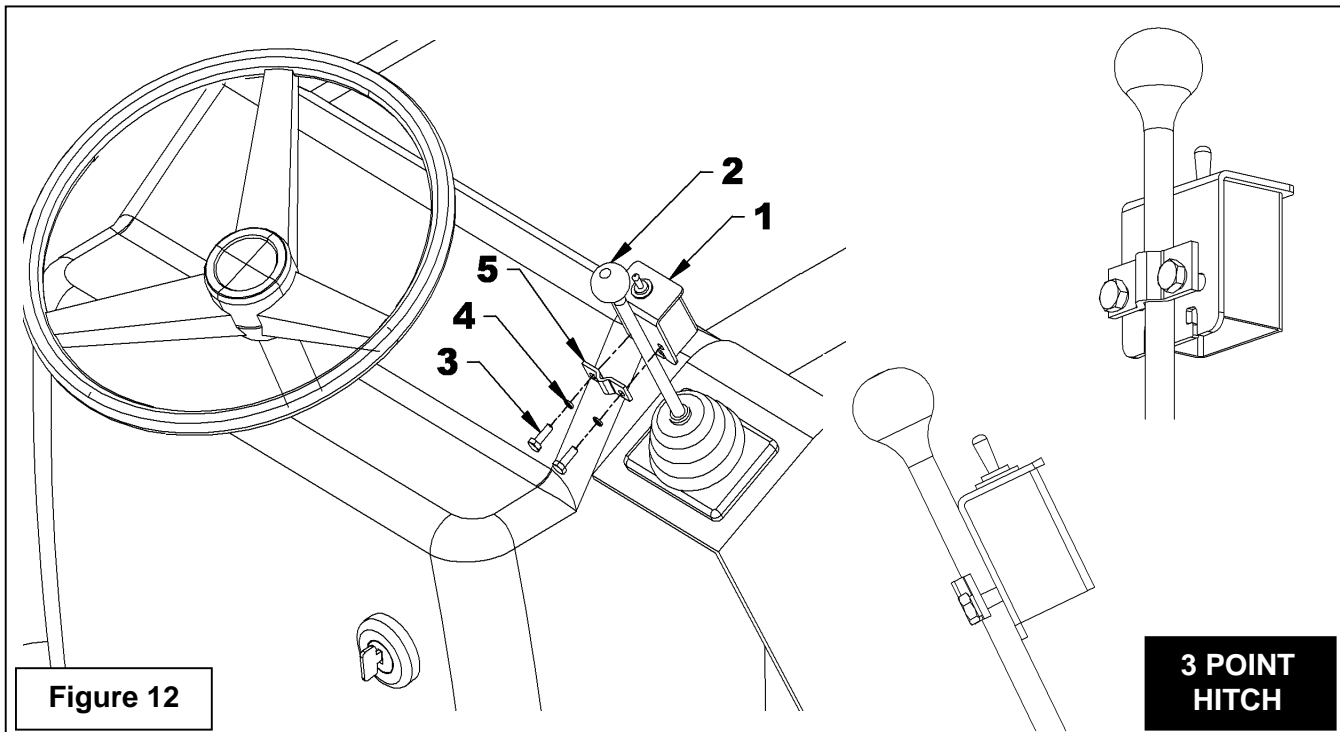
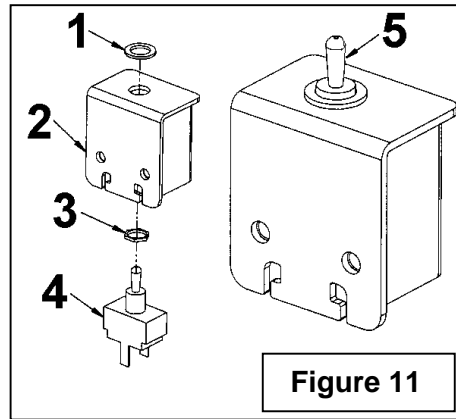
- 23.** Take the connector apart and insert the blue and black wires in the case (item 10).
- 24.** Connect the blue wire in hole #1 of the connection block (item 11) as illustrated on figure. Connect the remaining black wire of the wire assembly (item 1) in hole #2 as illustrated.
- 25.** Reinstall the connection block (item 11) in the case (item 10) taking care to place hole #3 on the same side as the case opening as illustrated so that it points toward the bottom to prevent water infiltration.
- 26.** Reassemble the DIN connector and reinstall on the electro-hydraulic valve (item 13) with the screw previously removed (item 9).
- 27.** Connect the two black wire terminals (items 1-3) together.
- 28.** Protect the wires with the  $\varnothing 3/8$ " loom. Apply electric tape every 12" and on the two terminals (item 1 et 3) to prevent water infiltration.
- 29.** Secure the wires in place with the nylon tie wraps.

# ASSEMBLY

## Installation of the Electrical Wiring –3 Point Hitch (Figures 11-12-13-14)

1. **Figure 11:** Insert the switch (item 4) in the switchbox (item 2) and secure together with the two nuts (items 1-3) supplied with the switch. Screw the rubber cap (item 5) on the switch.
2. **Figure 12** Place the switchbox (item 1) on the lever in a position that will be comfortable when the hand is on the knob and attach with the switchbox clamp (item 5), two 1/4"NC x 3/4" hex. bolts and two 1/4" lockwashers (item 4).

**NOTE:** Tighten the bolts just enough to securely fix the clamp and the switchbox on the lever. **DO NOT TIGHTEN TOO MUCH** so as not to deform the clamp.



# ASSEMBLY

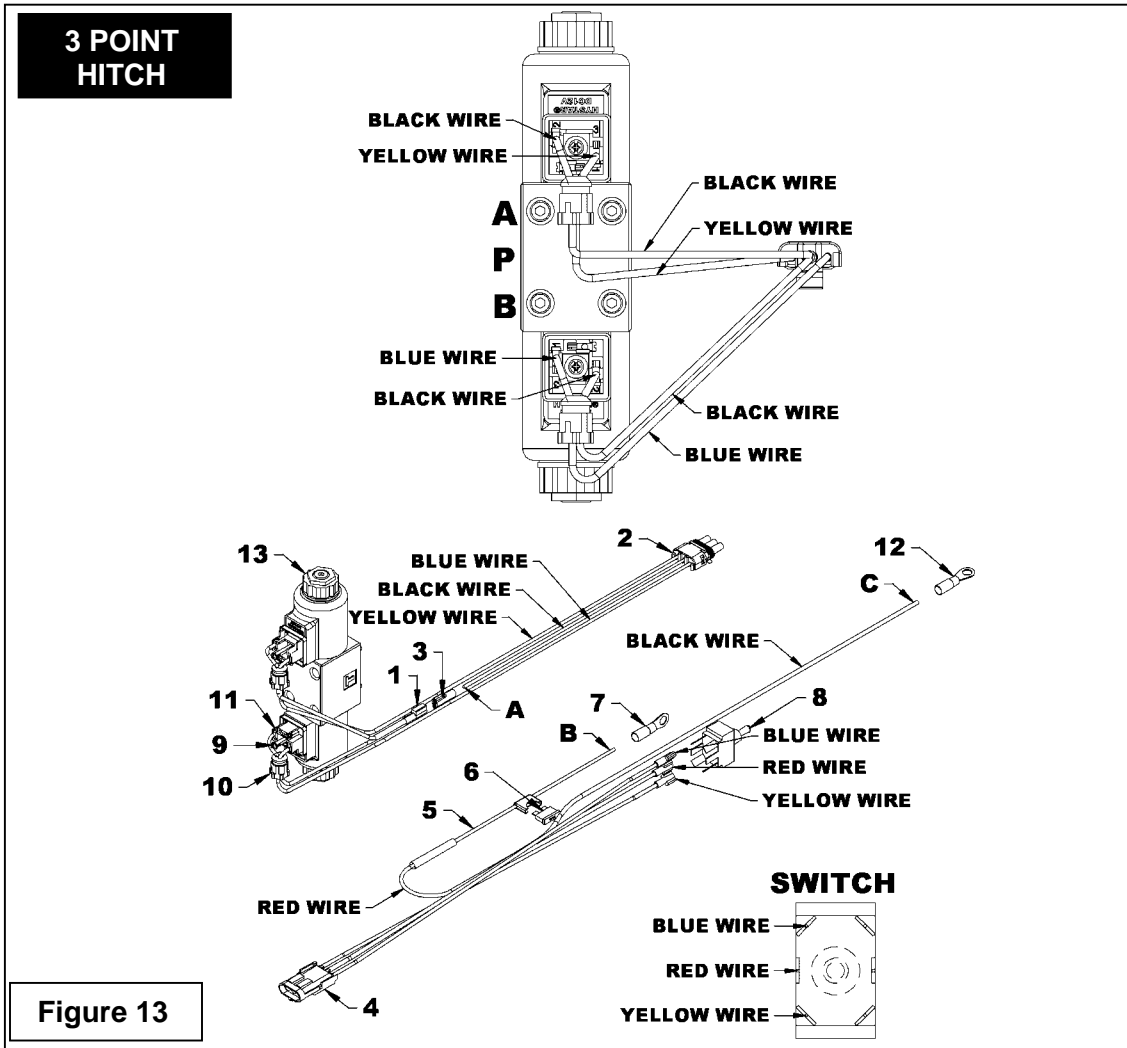


Figure 13

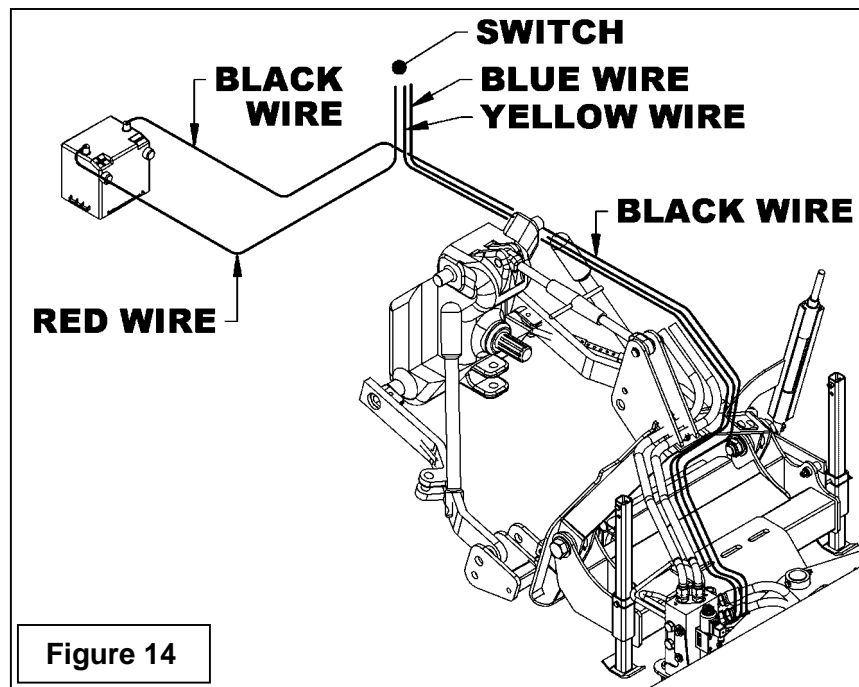


Figure 14

---

## ASSEMBLY

---

3. Attach the 3-cavity female connector (360" wire) (item 4) close to the vehicle's quick couplers with a nylon tie wrap Run the wires alongside the hydraulic hoses and the tractor frame before bringing them into the cab avoiding any areas liable to pinch the wires (see figure 14).
4. Wrap the electrical wires with the  $\varnothing 3/8$ " loom. Apply electrical tape every 12".
5. Secure the wires in place with the nylon tie wraps.
6. Connect all the wires (item 4 et 5) on the same side of the switch (item 8).
7. Connect the red battery wire (192" wire) (item 5) in the middle of the switch (item 8) on the same side as the blue and yellow wire. Run the wire through the vehicle all the way to the battery. Strip 3/8" from the wire end (item B), crimp a round terminal (item 7) then heat with a hot air gun to shrink the sheath on the wire.
8. Strip 3/8" from the end of the wire assembly's (item 4) black wire (item C), crimp a round terminal (item 12) then heat with a hot air gun to shrink the sheath on the wire. Install the round terminal (item 12) to make the ground.
9. Connect the round terminal (item 7) to the battery.
10. Insert the fuse (item 6) in the fuse holder of the battery wire (item 5).
11. Connect the 3-cavity male connector (item 2) to the 3-cavity female connector (item 3) and run it in alongside the hydraulic hoses up to the electro-hydraulic valve (item 13). Leave enough slack in the wires to allow for all the possible movements of the broom and the vehicle.
12. Cut the excess wire that isn't needed.
13. Strip 1/2" from the end of the wire assembly's (item 2) black wire (item A). Fold the stripped portion in two, twist and crimp a 1/4" female terminal (item 3).
14. Strip 1/4" from the end of the wire assembly's (item 2) yellow and blue wires.
15. Remove the upper DIN connector from the electro-hydraulic valve (item 13) by removing the screw (item 9) in front of the case (item 10).
16. Take the connector apart and insert the yellow and black wires in the case (item 10).
17. Connect the yellow wire in hole #1 of the connection block (item 11) as illustrated. Strip 1/4" from the end of the wire assembly's two black wires (item 1). Connect one black wire in the #2 hole as illustrated.
18. Reinstall the connection block (item 11) in the case (item 10) taking care to place hole #3 on the same side as the case opening as illustrated so that it points toward the bottom to prevent water infiltration.
19. Reassemble the DIN connector and reinstall on the electro-hydraulic valve (item 13) with the screw previously removed (item 9).
20. Remove the lower DIN connector (item 10) from the electro-hydraulic valve (item 13) by removing the screw (item 9) in front of the case (item 10).
21. Take the connector apart and insert the blue and black wires in the case (item 10).
22. Connect the blue wire in hole #1 of the connection block (item 11) as illustrated on figure. Connect the remaining black wire of the wire assembly (item 1) in hole #2 hole as illustrated.

---

# ASSEMBLY

---

23. Reinstall the connection block (item 11) in the case (item 10) taking care to place hole en #3 on the same side as the case opening as illustrated so that it points toward the bottom to prevent water infiltration.
24. Reassemble the DIN connector and reinstall on the electro-hydraulic valve (item 13) with the screw previously removed (item 9).

## **Installation of the Broom on a Skid Steer** **(Figures 15-16)**

1. Check to make sure the locking wedge levers (item 3) operate freely. If not, refer to the vehicle's operator's manual to perform the required maintenance.

2. Pull the locking wedge levers (item 3) all the way up.

**NOTE:** For vehicle equipped with an automatic locking wedge system, make sure the wedges are fully raised.

3. Start the vehicle and tilt the attach plate (item 2) at a 45° angle.

4. Move the vehicle forward until the attach plate (item 2) is under the upper part of the broom's universal hitch. The broom must come off the ground slightly.

5. Tilt the attach plate (item 2) backward until the broom is completely off the ground.

**NOTE:** For vehicle equipped with an automatic wedge locking system, press on the switch until the wedges are down completely (see **Figure 16**).

Pay attention to any unusual problem or noise. If that's the case, stop and check that everything is in place and start again.

6. Stop the vehicle completely and engage the parking brake. Exit the vehicle.

25. Connect the two black wire terminals (items 1-3) together.

26. Protect the wires with the ø3/8" loom. Apply electric tape every 12" and on the two terminals (item 1 et 3) to prevent water infiltration.

27. Secure the wires in place with the nylon tie wraps.

7. Lower the locking wedge levers to attach the broom to the vehicle.

**NOTE:** The locking wedges must extend under the universal hitch when the broom is properly attached to the vehicle. (see **Figure 13**).

8. Raise the four parking stands completely (item 5).

9. Connect the supply hoses (item 4) to the vehicle.



**WARNING** Make sure the hoses are locked in place or it could cause serious injuries to the broom operator.

**IMPORTANT:** It's important to install quick couplers that are compatible with the vehicle's quick couplers. The size and type must be identical.

Always make sure that the quick couplers, male and female, are clean since the least amount of dirt can damage the vehicle's hydraulic system.

10. Visually check the couplers for any trace of corrosion, cracking, damage or excessive wear due to extensive use. If any of these conditions exist, replace the defective coupler immediately.

# ASSEMBLY



## WARNING

Hydraulic oil, tubes, fittings and quick couplers can get hot when running the vehicle and the broom. Be careful when connecting and disconnecting the hydraulic hoses.

11. Sweep at low speed for about five minutes then stop the vehicle completely, engage the parking brake and check for any trace of oil leaks. Correct the situation if necessary.

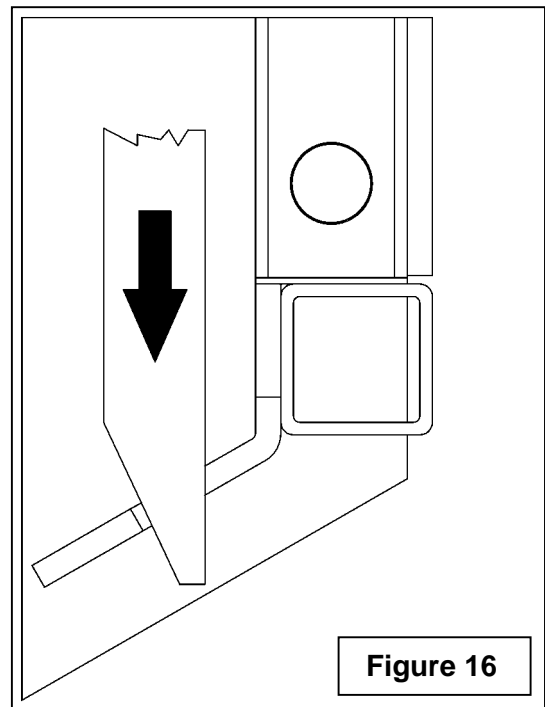
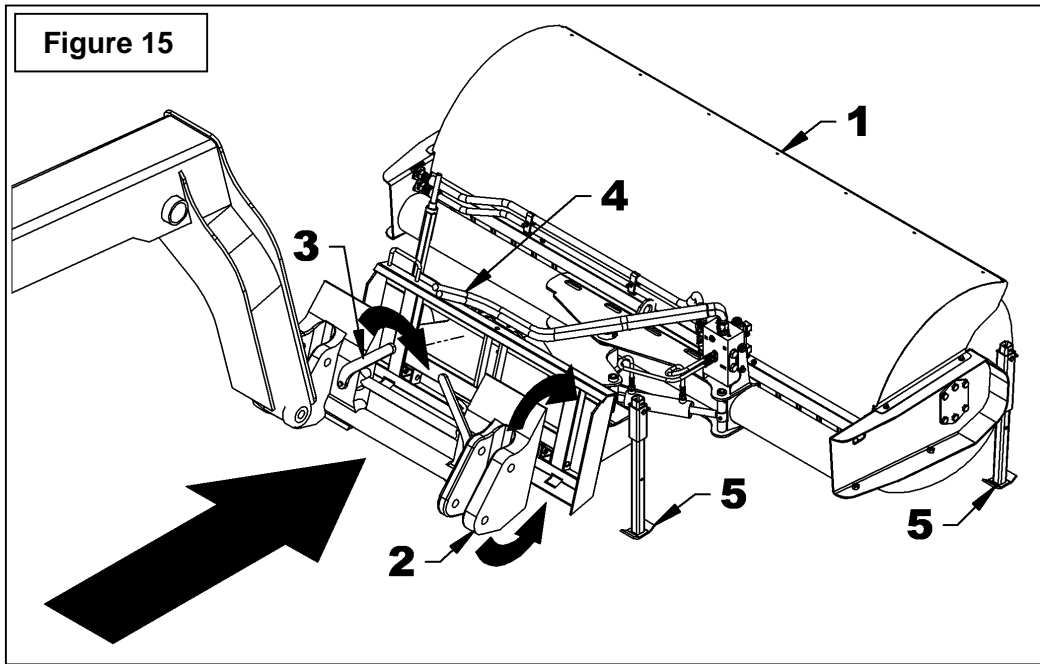
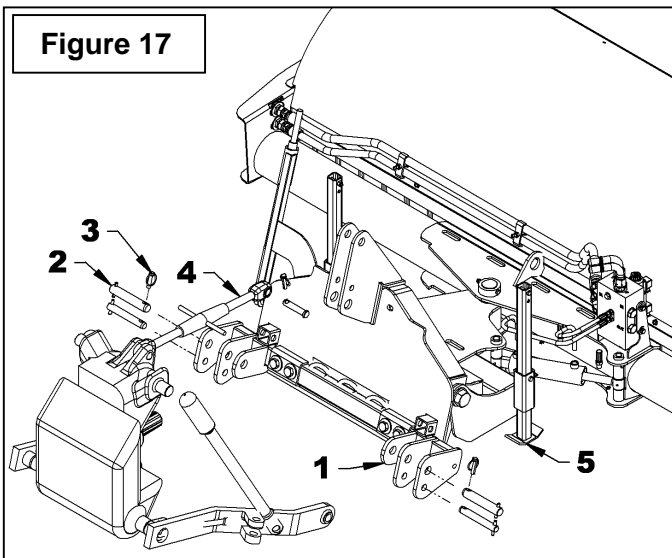


Figure 16

# ASSEMBLY

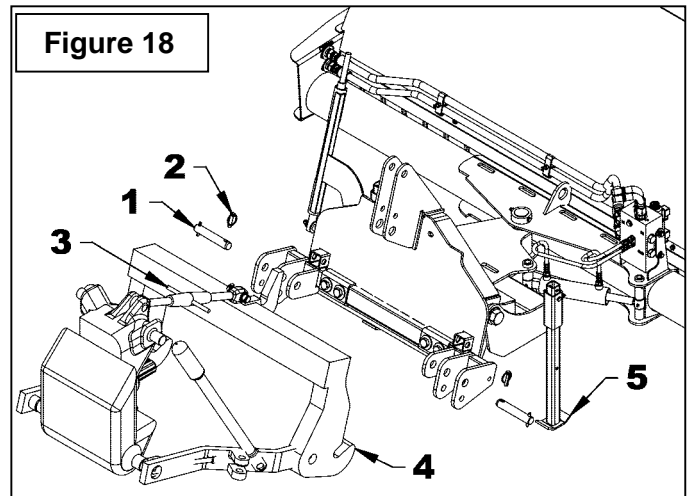
## Installation of the Broom on a 3 Point Hitch (Figure 17)

1. Lower the 3 point hitch as much as possible, turn off the engine, engage the parking brake and remove the ignition key.
2. Attach tractor lower hitch arms to the broom lower support (item 1) with two cat.1 or cat.2 (item 2) pin depending on tractor model and two  $\varnothing 7/16$ " linchpins (item 3).
3. Attach tractor upper hitch (item 4) to the broom upper support with the tractor pin and linchpin.
4. Adjust the tractor anti-sway turnbuckles so the broom does not sway. Be sure the turnbuckles clear the tractor tires.
5. Raise the four parking stands (item 5).
6. Go to the section "Adjusting the Ground Pressure".



## Installation of the Broom on a Quick Hitch (Figure 18)

1. Install two cat. 2 pins (item 1) fitted with a quick hitch sleeve (not included) and two  $\varnothing 7/16$ " linchpins (item 2) on the lower hitch.
2. Install the tractor upper pin fitted with a quick hitch sleeve (not included) and a linchpin on the 3 point hitch upper support.
3. Adjust the tractor anti-sway turnbuckles so the quick hitch does not sway. Be sure the turnbuckles clear the tractor tires.
4. Unscrew the tractor upper hitch (item 3) to place it at the same angle as the rear plate of the broom.
5. Lower the 3 point hitch, slowly backup the tractor and install the quick hitch upper hitch pin then raise the 3 point hitch slowly. When the lower pins are properly positioned lock the quick hitch jaws.
6. Raise the four parking stands (item 5).
7. Go to the section "Adjusting the Ground Pressure".



---

# ASSEMBLY

---

## **Removing Broom from Skid Steer** (Figure 19)

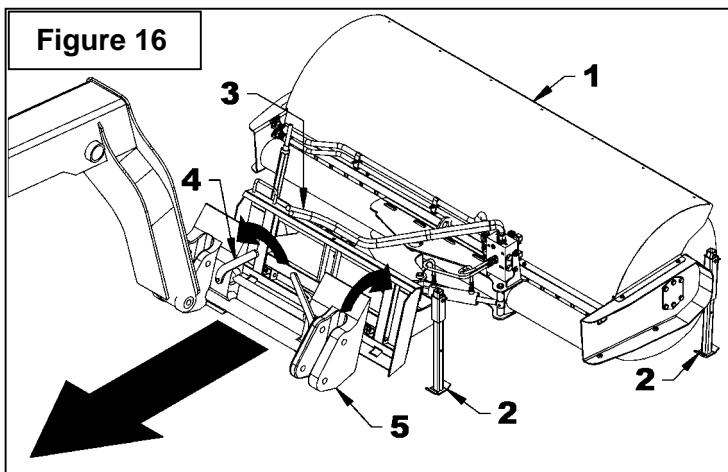
1. Lower the broom's four parking stands completely (item 5).
2. Disconnect the vehicle's supply hoses (item 4).
3. Lift the locking wedge levers to release the broom from the vehicle.
4. Start the vehicle and tilt the attach plate (item 2) at approximately 45°.
5. Tilt the attach plate (item 2) toward the front until the broom is free.
6. Back the vehicle up until the top of the attach plate (item 2) is no longer under the upper part of the broom universal hitch.

**NOTE:** For vehicle equipped with an automatic wedge locking system push the button until the locking wedges are completely raised.

Pay attention to any unusual problem or noise. If that's the case, stop and check that everything is in place and start again.

7. Stop the vehicle completely and engage the parking brake before leaving the vehicle.

**NOTE:** The locking wedges must not extend under the universal hitch when the broom is removed from the vehicle.



## **Removing Broom from 3 Point Hitch**

1. Lower the broom's four parking stands.
2. Lower the broom to the ground to relieve all the pressure on the 3 point hitch. Engage the parking brake and turn the tractor off.
3. Loosen the upper adjustable arm to relieve the pressure it exercises on the broom's compression springs.
4. Detach the upper adjustable arm by removing the linchpin and the adjustable arm pin.
5. Disconnect the hoses and the electrical wires.
6. Slowly detach the lower hitch arms by removing the linchpins and the pins then loosen the anti-sway turnbuckles.

## **Removing Broom from Quick Hitch**

1. Lower the broom's four parking stands.
7. Lower the broom to the ground to relieve all the pressure on the 3 point hitch. Engage the parking brake and turn the tractor off.
2. Loosen the upper adjustable arm to relieve the pressure it exercises on the broom's compression springs.
3. Raise the lower quick hitch locks.
4. Disconnect the hydraulic hoses and the electrical wires.
5. Start the tractor, lower the 3 point hitch and drive forward slowly.

---

# OPERATION

---

## GENERAL PREPARATION

1. Check that hoses are connected correctly.
2. Make sure that the broom operates freely.
3. Secure the parking stands in the position where they do not touch the ground (up).



**WARNING:** To avoid serious injuries:

- Do not allow bystanders near working area.
- Do not allow anyone to ride on rotary broom.
- Before cleaning, adjusting or repairing the rotary broom: bring the tractor to a complete stop, wait for all movement to stop, apply parking brake, lower the implement to the ground, shut off the engine and remove the ignition key.
- Never put any part of your body under the rotary broom while making adjustments.



### **ATTENTION**

Always operate the broom from the operator's seat only. Never allow anyone to ride on the machine.



### **ATTENTION**

Operate the broom at a speed that matches the working conditions. Be extremely careful when working on banks or uneven terrain.



### **ATTENTION**

Always wear protective eyewear when operating the broom.

## OPERATION

### **Rotary Broom Controls**

1. Use the hydraulic remote to start and stop the brush. Start the engine and put the throttle lever at low engine speed. Engage the hydraulic control lever and maintain engaged. Make sure the broom is turning in the right direction. If not, switch the quick couplers. To stop the rotation, disengage the hydraulic control lever.
2. Never engage or disengage the rotary broom at high engine speed or the hydraulic motor(s) could get damaged.
3. Raise and lower the broom using the hydraulic lift lever located on the tractor. Pulling the lever backward raises the broom, pushing the lever forward lowers the broom.
4. Control brush speed with the RPM. Under most conditions, if the brush speed is too fast, it results in debris coming over the hood onto the operator.

### **Hydraulic Angling Adjustment**

To actuate the hydraulic cylinder that adjusts the broom angle, the brush must be touching the grounds and in operation.

Use the switch to turn the broom left or right to a maximum angle of 23°. If the broom does not move in the desired direction, reverse the yellow and blue wires under the switch.

# OPERATION

## Ground Pressure Adjustment (Figures 20-21-22-23)

1. Adjust the ground pressure when the broom is attached to a Skid Steer, a front loader or a tractor three point hitch.

2. **For a skid steer or a front loader, Figure 20:** Tilting the plate backward increases the ground pressure. Tilting the plate pushes the base toward the springs thus increasing their tension.

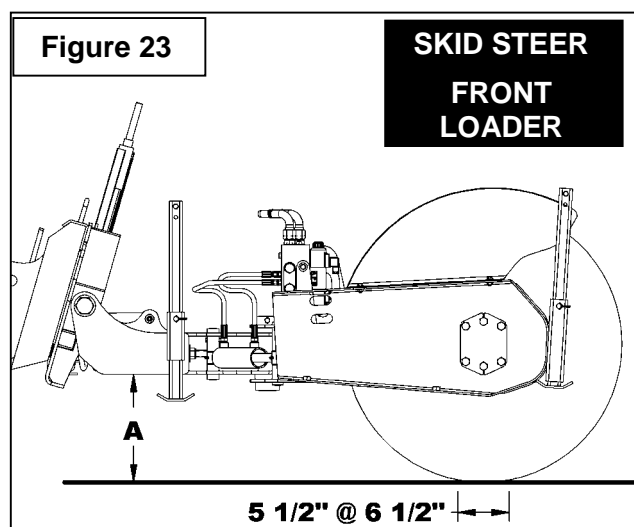
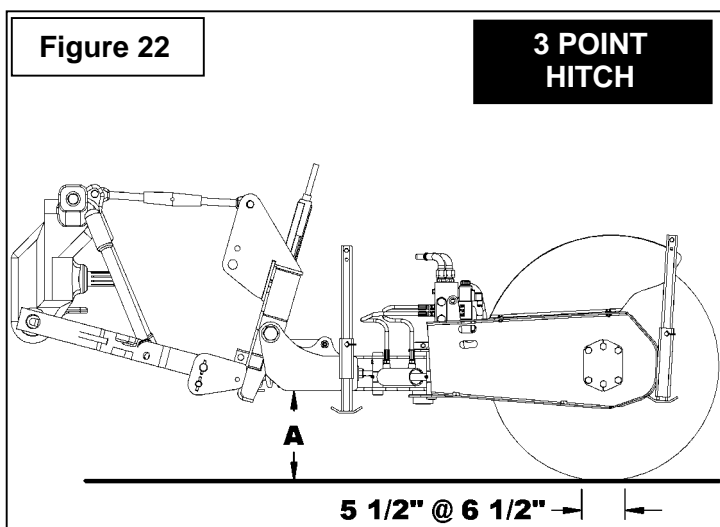
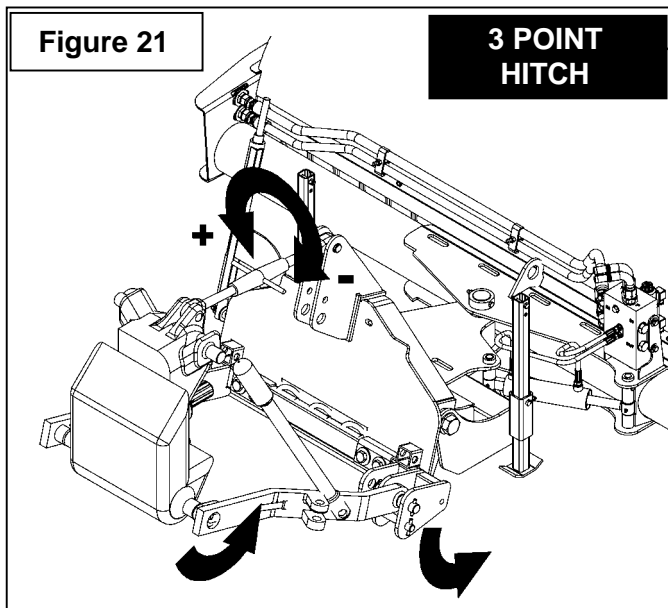
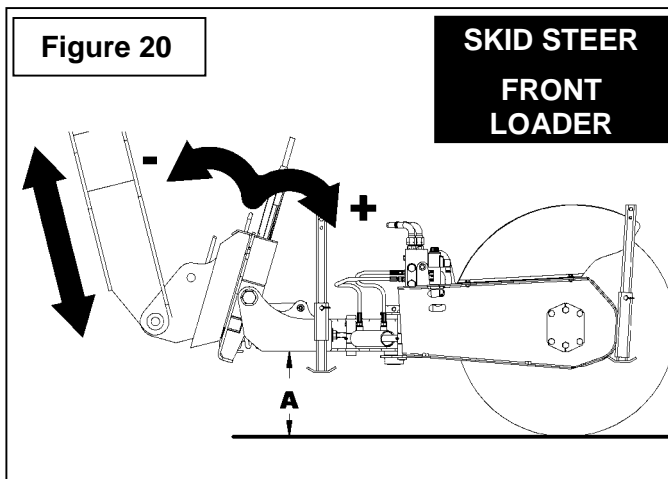
**For a 3 point hitch, Figure 21:** Turn the upper adjustable arm to the left to increase ground pressure. Turning the adjustable arm to the left pushes the base toward the springs thus increasing their tension.

3. The broom middle hitch must always be parallel to the ground (measure A).

4. For the most efficient sweeping, the brush must have good ground contact without too much pressure being placed on the bristles in order to prevent them from bending which would result in premature wear of the brush.

5. Make sure the vehicle's tire pressure is well adjusted.

6. Find a hard and dirty surface. Lower the brush to the ground, engage the broom and let the brush turn for 15 seconds while remaining in place. Disengage the broom without raising it and wait for the brush to stop turning.

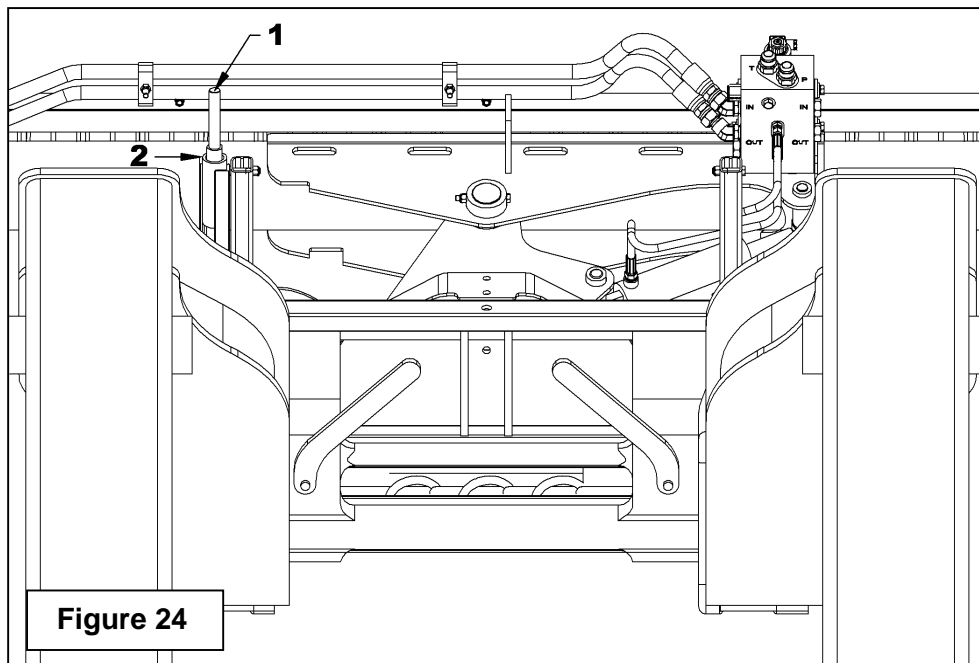


---

## OPERATION

---

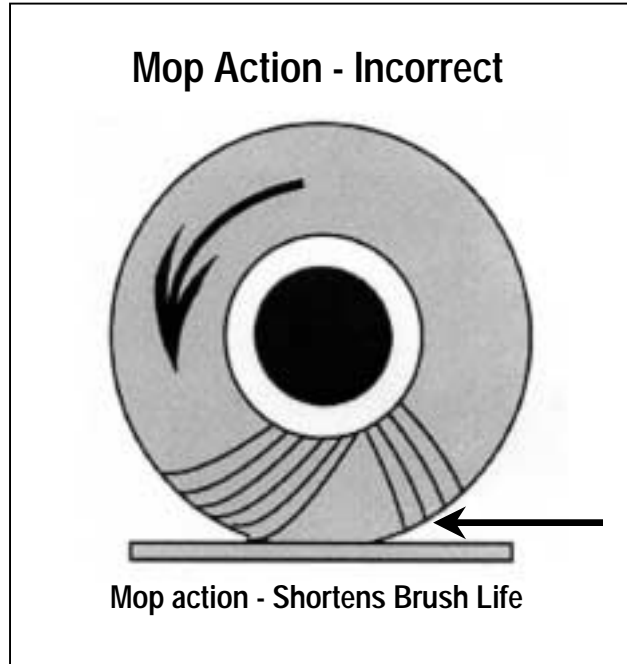
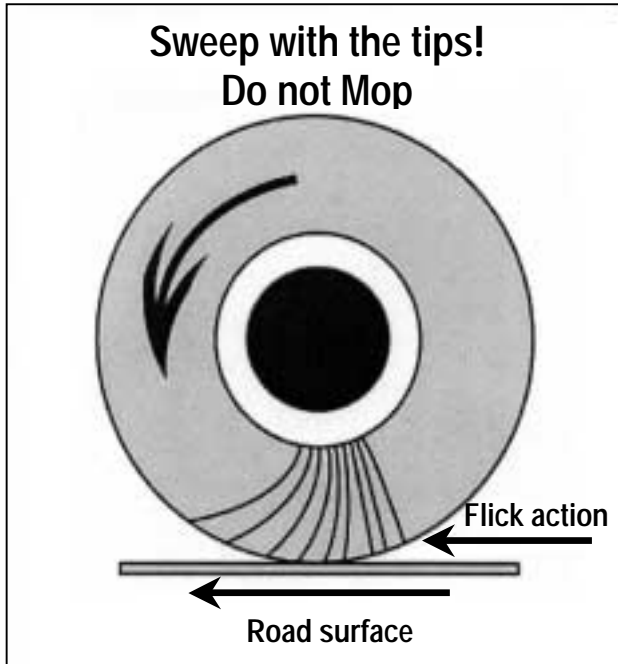
7. Back up the vehicle without raising the broom or you will lose the reference point for the ground pressure adjustment. Once completely stopped, turn off the engine.
8. Measure the cleaned strip. If the adjustment is correct, the strip should measure between 5 1/2" and 6 1/2" (140 and 165mm) wide and the two ends of the strip should be parallel. Repeat the procedure until the recommended width is obtained.
9. When the 6" wide strip is obtained, climb on the vehicle and, for a 3 point hitch, lock the lever arm to maintain the position of the broom.
10. **Figure 18:** For tractors not equipped with locks or when the broom is attached to a skid steer or a front loader, this broom is fitted with a ground pressure indicator (item 1). From the seated position, locate the number and the line on the rod (item 1) on the side of the indicator support (item 2) that corresponds to the correct ground pressure for the current environment. If you must raise the broom to move, simply reset the indicator at the same line and number previously determined.



# OPERATION

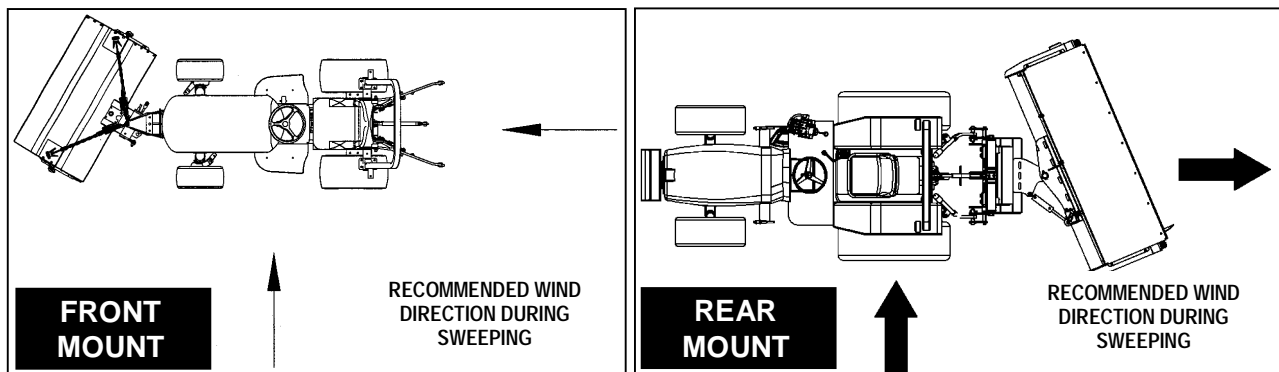
The rotary broom's suspension design keeps the ground pressure of the brush constant and within a pressure range that makes the brush sweep with the tips of the bristles for a longer brush life.

Improper downward pressure can decrease brush life up to 95%. The broom must sweep with the bristle tips. When too much down pressure is applied, the broom no longer uses the tips; the broom cleans with the sides of the bristles. This limits the flicking action of the bristles and limits its sweeping effectiveness.



## **General Sweeping**

1. Minimize dust by reducing brush speed and by sweeping on days with high moisture.
2. For light material, angle broom half way to the right or to the left rather than fully angled to obtain a wider sweeping path.
3. For heavier material, reduce ground speed and angle the brush fully to the left or right to expel the accumulated debris from the sweeping path as quickly as possible thus preventing build up.
4. Prevent damage to the broom by removing large foreign objects.



---

# OPERATION

---

## **Lawn Dethatching & Leaf Raking**

**IMPORTANT:** Optional lawn dethatching wheels must be installed to perform these tasks in order to avoid excessive ground contact.

1. Bristles should barely touch the ground for lawn dethatching and leaf raking operations.
2. To adjust the height of the wheel slide the inner tube upward or downward, as needed, and insert the square wire lock pin in the open hole.
3. We recommend adjusting the wheel height to 1" lower than the brush height to make a first try on the grass. Then raise or lower the wheels as required.
4. Slower brush speed and ground speed are more adequate for lawn dethatching. This will avoid bouncing which could damage the lawn due to excessive ground contact.

## **Snow Removal**



### **WARNING:**

**To avoid serious injuries: Foreign objects in snow may be thrown farther than the snow. Use the slowest brush speed that will perform the job. Stay aware of broom discharge direction.**



### **WARNING:**

**To avoid serious injuries: Snow or ice build-up on the sweeper hood can cause a loss of tractor steering control. Regularly remove any snow or ice from the sweeper hood to prevent the excess weight from affecting steering.**

1. This broom's optimum performance is achieved when snow depth is 5" (127 mm) or less.
2. To avoid the snow from being blown back on the tractor and operator, sweep with the wind blowing in the direction of broom discharge.

3. Vary the brush speed and broom angle so the brush throws material on each side to prevent excessive accumulations.
4. Brush speed must be at its maximum to obtain a better performance in wet, heavy snow or slush

## **TROUBLESHOOTING**

### **Uneven Wear of the Brush**

- Make sure there is no debris wrapped around the brush.
- Check the ground pressure adjustment (see section "Ground Pressure Adjustment").
- Remove the accumulated debris under the hood.

### **Debris Accumulation in Front**

- Reduce the travel speed.
- Increase the engine rpm.
- Make more than one pass.
- Raise the brush to decrease the contact area.
- Increase the broom angle.

### **The Brush Bounces**

- The operator transmits a vibration to the accelerator (HST pedal). Solution: Use the cruise control.
- The quantity of debris being swept is too large. Solution: Reduce the width of the sweeping path and place the broom at an angle to prevent an accumulation of debris.

**Note:** The travel speed of the tractor and the down pressure of the brush will have little effect on this condition.

---

## OPERATION - MAINTENANCE

---

### **Rear Debris Being Thrown Back**

- The quantity of debris being swept is too large. Solution: Reduce the width of the sweeping path and place the broom at an angle to prevent an accumulation of debris.

**Note:** The travel speed of the tractor and the down pressure of the brush will have little effect on this condition. It is therefore recommended keeping the same sweeping settings and to make a second pass to complete the job.

### **Debris Left on the Ground**

- The travel speed of the tractor is too fast. Slow down.
- The ground pressure of the brush is too low. Solution: Increase pressure with the engagement levers located on the top of the broom.

**Note:** The higher the ground pressure of the brush is, the more the brush life is reduced.

## **MAINTENANCE**

### **ALWAYS USE GENUINE PARTS WHEN REPLACEMENT PARTS ARE REQUIRED.**

1. Avoid exposing broom bristles to direct sunlight for long periods to avoid damage.
2. Because of the dust raised during sweeping, the tractor air cleaner should be checked daily and replaced when necessary.

# MAINTENANCE

## **Brush Replacement**

**(Figure 25)**

When the wafers reach a diameter of 18", it is necessary to replace them in order to maximize the performance of your broom.

**NOTE:** The broom does not need to be attached to the vehicle to replace the brush

1. Set the rotary broom on the four parking stands (item 13).
2. Remove the four 1/2"NC x 2 1/2" allen socket head cap screws (item 1) and the four 1/2"NC nylon insert nuts (item 2) holding the hydraulic motor (item 3).
3. If there are two motors, remove the second motor in the same way and go to step 5.
4. Remove the two 1/2"NC x 1 1/2" hex bolts (item 5) and the two 1/2"NC nylon insert nuts (item 6) holding the bearing.
5. Remove the brush support and the bearing from the broom housing (item 8).
6. Remove the four 3/8"NC x 2 1/2" hex. bolts (item 9), the four lockwashers (item 10) and the retaining plate (item 11).
7. Remove the brushes (item 12) from the brush support (item 8).
8. Clean the brush support (item 8) and do a visual inspection for any signs of damage or cracks and repair if needed before installing the new brushes.

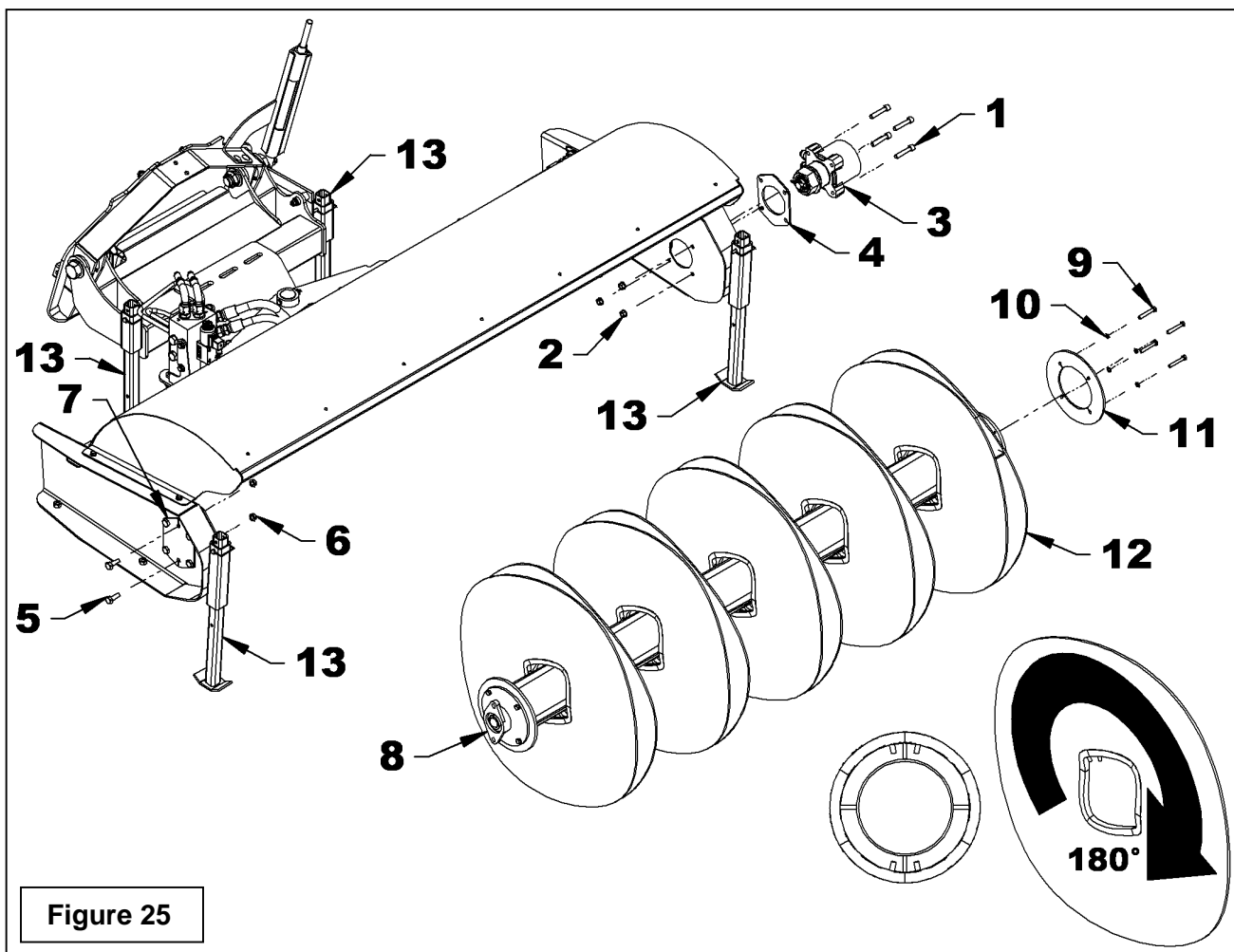


Figure 25

# MAINTENANCE

9. For brooms with only one motor, check for any sign of wear on the drive plate at the end of the brush support. Make sure the six or twelve nuts (if 2 motors) holding the drive plate(s) are tightened at 55 lb/ft.
10. Install the new brushes (item 12) on the brush support (item 8) by aligning the guides on each side of one of the brush support tubes and rotating each brush 180° (see figure 25).
11. Shake the brushes (item 12) before installing the retaining plate (item 11) to compress them.
12. Reinstall the retaining plate (item 11) and secure in place with the four 3/8" NC x 2 1/2" hex. bolts and the four lockwashers (items 9-10). There should be no gap between the brushes once the retaining plate is installed.
13. Place the brush support (item 8) under the broom cover.

### ***If the broom is fitted with only one motor:***

14. Lift the brush support (item 8) with a jack. Insert the bearing in its opening placing the grease fitting toward the outside and attach to the support plate (item 7) with the two 1/2" NC x 1 1/2" hex. bolts (item 5) and the two 1/2" NC serrated flange nuts (item 6). The holes must align perfectly or the broom might bounce.
15. Move the jack at the end where the electric motor (item 3) is installed. Raise the brush support (item 8) to align it with the opening in the housing. Insert the hydraulic motor hub (item 3) in the brush support. It might be necessary to turn the brush support to align the hub faces with the drive plate bolted to the brush support.
16. Attach the hydraulic motor (item 3) and its spacer (item 4) to the broom housing with the four 1/2" NC x 2 1/2" allen socket head cap screw (item 1) and the four 1/2"NC serrated flange nuts (item 2).
17. **NOTE:** If the hydraulic motor (item 3) is too tight against the brush support (item 12), add the 1/8" spacer included in the hardware box.

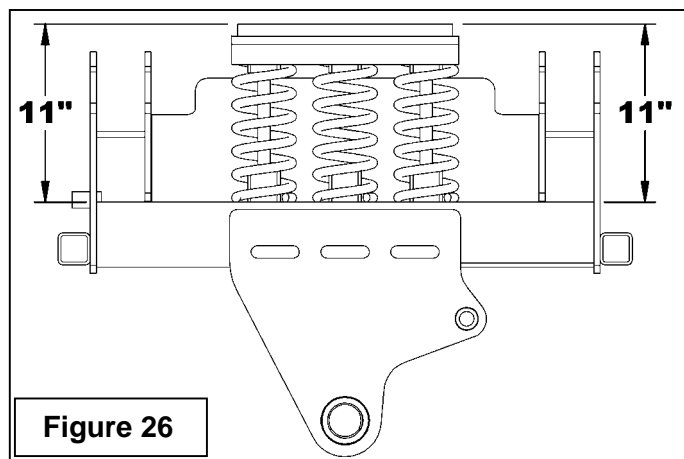
### ***If the broom is fitted with two motors:***

18. Move the jack at the end where the left electric motor (item 3) is installed. Raise the brush support (item 8) to align it with the opening in the housing. Insert the hydraulic motor hub (item 3) in the brush support. It might be necessary to turn the brush support to align the hub faces with the drive plate bolted to the brush support.
19. Attach the hydraulic motor (item 3) and its spacer (item 4) to the broom housing with the four 1/2" NC x 2 1/2" allen socket head cap screw (item 1) and the four 1/2"NC serrated flange nuts (item 2).
20. Follow the same procedure to install the right motor.

### **Compression Springs** ***(Figure 26)***

The compression springs must always be adjusted at the same length in order to provide high quality sweeping. **NEVER CHANGE THE CONFIGURATION OF THE SPRINGS.**

Check that the springs are correctly compressed by measuring from the rear of the middle hitch to the top of the spring support as illustrated. If the distance is not 11" (280 mm) adjust the springs with the tension bolts.



---

# MAINTENANCE

---

## **STORAGE**

Before storing the rotary broom, certain precautions should be taken to protect it from deterioration.

1. Clean the rotary broom thoroughly.
2. Make all the necessary repairs.
3. Repaint all parts from which paint has worn or peeled.
4. Lubricate the rotary broom as instructed under *Lubrication*.
5. Replace all decals that are damaged, lost, or otherwise become illegible. If a part to be replaced has a sign on it, obtain a new decal from your dealer and install it in the same place as on the removed part.
6. When the rotary broom is dry, oil all moving parts. Apply oil liberally to all surfaces to protect against rust.

**IMPORTANT: Do not allow oil or grease on broom bristles.**

7. Store broom on parking stands so that the bristles do not touch the ground.
8. Store in a dry place.

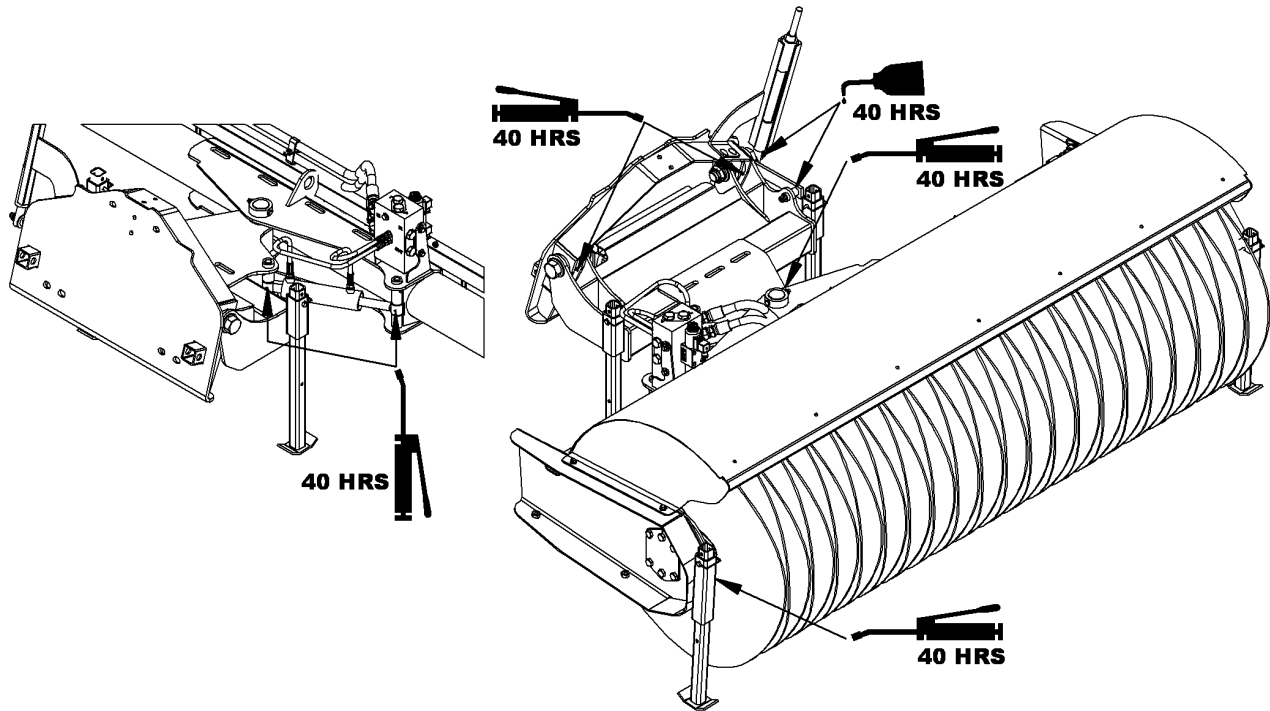
**IMPORTANT: If broom bristles are exposed to direct sunlight, protect bristles with a tarp**

# MAINTENANCE

## LUBRICATION

Use a grease gun, grease and lubricate as follows:

DESCRIPTION	TIME INTERVAL	LUBRICATION REQUIRED
All Pivot Points	40 hours	Use a good quality multipurpose lubricant
Bearing	40 hours	Grease the bearing



## PERIODIC CHECKS

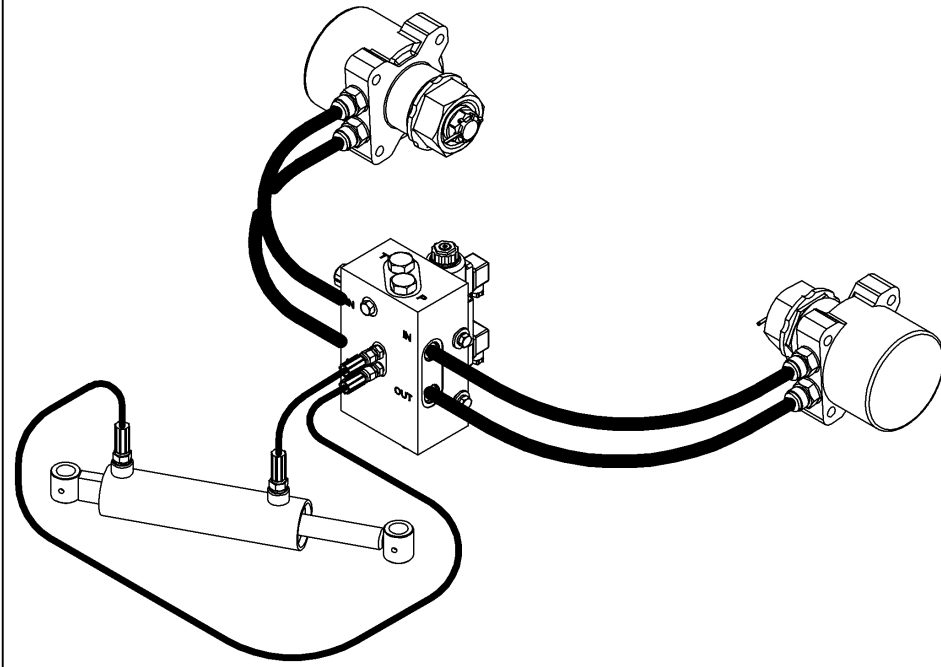
DESCRIPTION	TIME INTERVAL	REQUIRED CHECKS
Hoses	Each lubrication	Check for leaks
Hydraulic motor	Each lubrication	Check for leaks
Hydraulic block	Each lubrication	Check for leaks
Brushes	100 hours of use	Check for wear and replace if needed
Housing, hitches, brush support	100 hours of use	Repair if needed
Hardware	24 hours of use	Check and tighten if needed

---

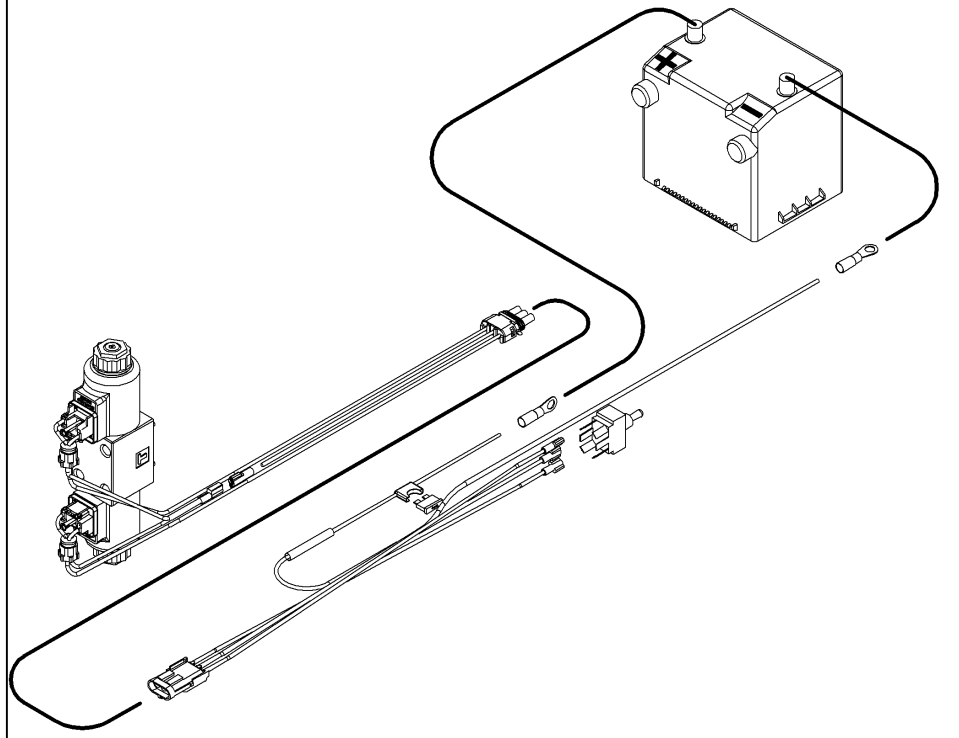
# DIAGRAMS

---

## HYDRAULIC



## ELECTRIC



# SPECIFICATIONS

<b>MODEL</b>	<b>HB6032</b>	<b>HB6032X</b>	<b>HB7232</b>	<b>HB7232X</b>	<b>HB8432</b>	<b>HB8432XX</b>
Width – in (cm)	60 (152)	60 (152)	72 (183)	72 (183)	84 (213)	84 (213)
Recommended capacity – GPM	10 to 18	12 to 22	10 to 18	12 to 22	12 to 22	20 to 38
Recommended pressure - PSI	2100 to 3600	2100 to 3600	2100 to 3600	2100 to 3600	2100 to 3600	2100 to 3600
Brush type	wafer	wafer	wafer	wafer	wafer	wafer
Brush 100% polypropylene	standard	standard	standard	standard	standard	standard
Brush polypropylene/steel	option	option	option	option	option	option
Brush diameter – in (cm)	32 (81)	32 (81)	32 (81)	32 (81)	32 (81)	32 (81)
Angle	23°-0°-23°	23°-0°-23°	23°-0°-23°	23°-0°-23°	23°-0°-23°	23°-0°-23°
Manual angling	n/a	n/a	n/a	n/a	n/a	n/a
Hydraulic angling	standard	standard	standard	standard	standard	standard
Sweeping width going straight – in (cm)	60 (152)	60 (152)	72 (183)	72 (183)	84 (213)	84 (213)
Sweeping width at maximum angle– in (cm)	55 (140)	55 (140)	66 (168)	66 (168)	77 (196)	77 (196)
3 point hitch Cat.1,2 Quick hitch Cat. 1,2	option	option	option	option	option	option
Universal hitch for skid steer	option	option	option	option	option	option
Universal hitch for front loader	option	option	option	option	option	option
Second hydraulic motor	option	n/d	option	n/d	n/d	standard
Dust deflector	option	option	option	option	option	option
Lawn dethatching wheels	option	option	option	option	option	option
Parking stands	standard	standard	standard	standard	standard	standard
Shipping weight - (lb/kg)	691 (313)	693 (314)	744 (337)	746 (338)	800 (363)	840 (381)

---

# PARTS

---

## **INTRODUCTION**

All parts are illustrated in "exploded views" which show the individual parts in their normal relationship to each other. Reference numbers are used in the illustrations. These numbers correspond to those in the "Reference Number" (REF) column, and are followed by the description and quantity required.

O/L - "Obtain Locally" in the part number column indicates common hardware that is available at your local hardware supply.

All reference to right and left, forward or rearward, are from the operator seat, looking at the machine while operating.

Orders must give the complete description, correct part number, the total amount required, the serial number, the method of shipment and the shipping address.

The manufacturer reserves the rights to change, modify, or eliminate from time to time, for technical or other reasons, certain or all data, specifications, or the product or products themselves, without any liability or obligation.

The parts listed here are available through your local dealer.

# PARTS

## DECALS

Replace immediately if damaged

**WARNING**

FAILURE TO FOLLOW SAFE OPERATING PROCEDURES MAY RESULT IN INJURY.

1. READ SAFE OPERATING INSTRUCTIONS AND ALL OPERATING INSTRUCTIONS CAREFULLY BEFORE OPERATING THE MACHINE.

2. ALWAYS WEAR YOUR SEATBELT AND SAFETY BELT AT ALL TIMES.

3. KEEP HANDS, FEET AND CLOTHING AWAY FROM ROTATING PARTS.

4. STOP ENGINE BEFORE LEAVING OPERATOR POSITION.

5. MAKE SURE ALL MOVEMENTS TO STOP BEFORE STARTING TO ADJUST, LUBRICATE, CLEAN OR SERVICING THE MACHINE.

6. KEEP THE AREA OF OPERATION CLEAR OF ALL PERSONS AND ANIMALS.

7. KEEP ALL GUARDS AND SHIELDS IN PLACE.

8. STOP ENGINE BEFORE ANY TOWING OR TOWING, UNLESS OTHERWISE SPECIFIED.

9. ALWAYS USE A SHOCK ABSORBER WHEN MOVING IN SLOPED TERRAIN.

10. KEEP PLASTIC MATERIALS AWAY FROM ENGINE, HEAT AND OPEN FLAMES.

11. NEVER ALLOW PASSENGERS ON THE STEERING.

660988

**MISE EN GARDE**

ÉCHEC À SUIVRE LES PROCÉDURES D'OPÉRATION PEUT CAUSER DES BLESSURES.

1. LIRE ATTENTIVEMENT LES INSTRUCTIONS D'OPÉRATION ET TOUTES LES INSTRUCTIONS D'UTILISATION ET DE PRÉCAUTIONS SÉCURITAIRES DANS LE MANUEL.

2. TOUJOURS PORTER SA CEINTURE DE SÉCURITÉ EN TOUT MOMENT.

3. PORTER TOUJOURS SA CEINTURE DE SÉCURITÉ EN TOUT MOMENT.

4. PORTER TOUJOURS SA CEINTURE DE SÉCURITÉ EN TOUT MOMENT.

5. PORTER TOUJOURS SA CEINTURE DE SÉCURITÉ EN TOUT MOMENT.

6. PORTER TOUJOURS SA CEINTURE DE SÉCURITÉ EN TOUT MOMENT.

7. PORTER TOUJOURS SA CEINTURE DE SÉCURITÉ EN TOUT MOMENT.

8. PORTER TOUJOURS SA CEINTURE DE SÉCURITÉ EN TOUT MOMENT.

9. PORTER TOUJOURS SA CEINTURE DE SÉCURITÉ EN TOUT MOMENT.

10. PORTER TOUJOURS SA CEINTURE DE SÉCURITÉ EN TOUT MOMENT.

660989

5  
4  
3  
2  
1

2500642

**MISE EN GARDE**

**POINT DE PINCEMENT**  
CHÂSSIS PIVOTANT.  
PEUT PROVOQUER DES BLESSURES:

- Garder mains et pieds éloignés.

660990

**WARNING**

**PINCH POINT**  
AVOID INJURY FROM FRAME PIVOT AND STOPS:

- Keep hands and feet away.

658710

**MISE EN GARDE**

**POINT DE PINCEMENT**  
CHÂSSIS PIVOTANT.  
PEUT PROVOQUER DES BLESSURES:

- Garder mains et pieds éloignés.

660990

HB6032 – 2500637  
B6032X – 2500638  
HB7232 – 2500635  
HB7232X – 2500636  
HB8432 – 2500633  
HB8432XX – 2500634



**WARNING**

TO AVOID INJURY, STAY CLEAR OF ROTATING BROOM.

**ATTENTION**

POUR ÉVITER DES BLESSURES, SE TENIR ÉLOIGNÉ DU BALAI EN MOUVEMENT.

406

2500354

**IMPORTANT**

**BRUSH ADJUSTMENT**

- FIND A FLAT SURFACE
- SWEEP FOR 15 SEC.
- SWEEP PATH MUST BE RECTANGULAR AND BETWEEN 5 1/2" AND 6 1/2" WIDE
- ADJUST GROUND PRESSURE

SWEEP PATH

5 1/2" @ 6 1/2"

GOOD

BAD

BAD

REFER TO OPERATOR'S MANUAL 602

2500648

**IMPORTANT**

**AJUSTEMENT DE LA BROSSÉ**

- TROUVER UNE SURFACE PLANE
- BROSSER PENDANT 15 SEC.
- LA SURFACE BALAYÉE DOIT ÊTRE RECTANGULAIRE ET ENTRE 5 1/2" ET 6 1/2"
- AJUSTER LA PRESSION AU SOL

SURFACE DE BALAYAGE

5 1/2" @ 6 1/2"

BON

MAUVAIS

MAUVAIS

SE RÉFÉRER AU MANUEL DE L'UTILISATEUR 603

2500649

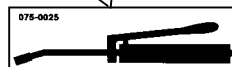
**WARNING**

HYDRAULIC FLUID UNDER PRESSURE CAN PENETRATE THE SKIN CAUSING SERIOUS INJURY.

**ATTENTION**

UN LIQUIDE HYDRAULIQUE SOUS PRESSION PEUT PÉNÉTRER LA PEAU ET CAUSER DES BLESSURES SÉRIEUSES.

2500400



664391



2500624

**WARNING**

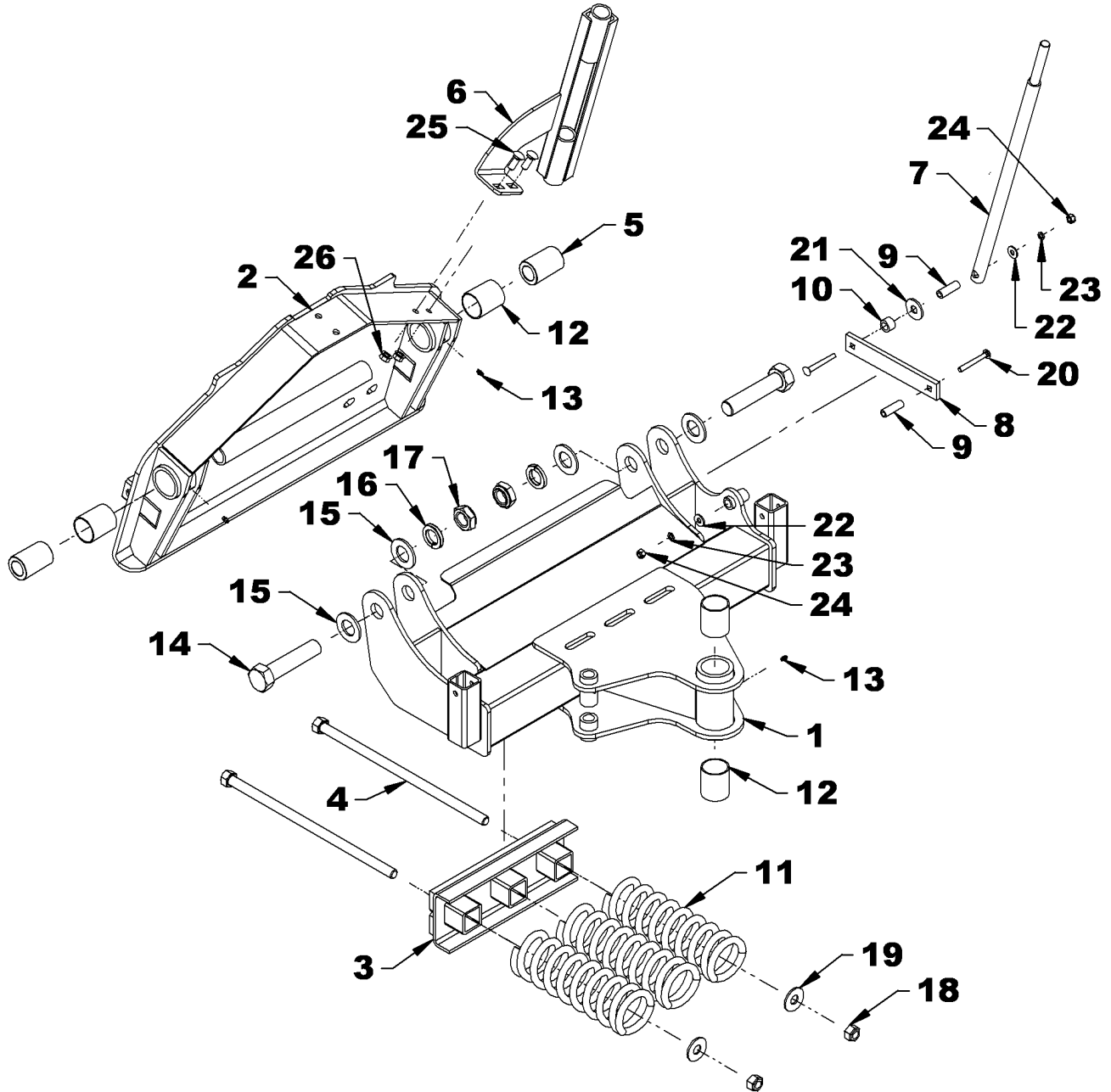
**PINCH POINT**  
AVOID INJURY FROM FRAME PIVOT AND STOPS:

- Keep hands and feet away.

658710

# PARTS

## ROTARY BROOM - HITCH



---

# PARTS

---

## ROTARY BROOM - HITCH

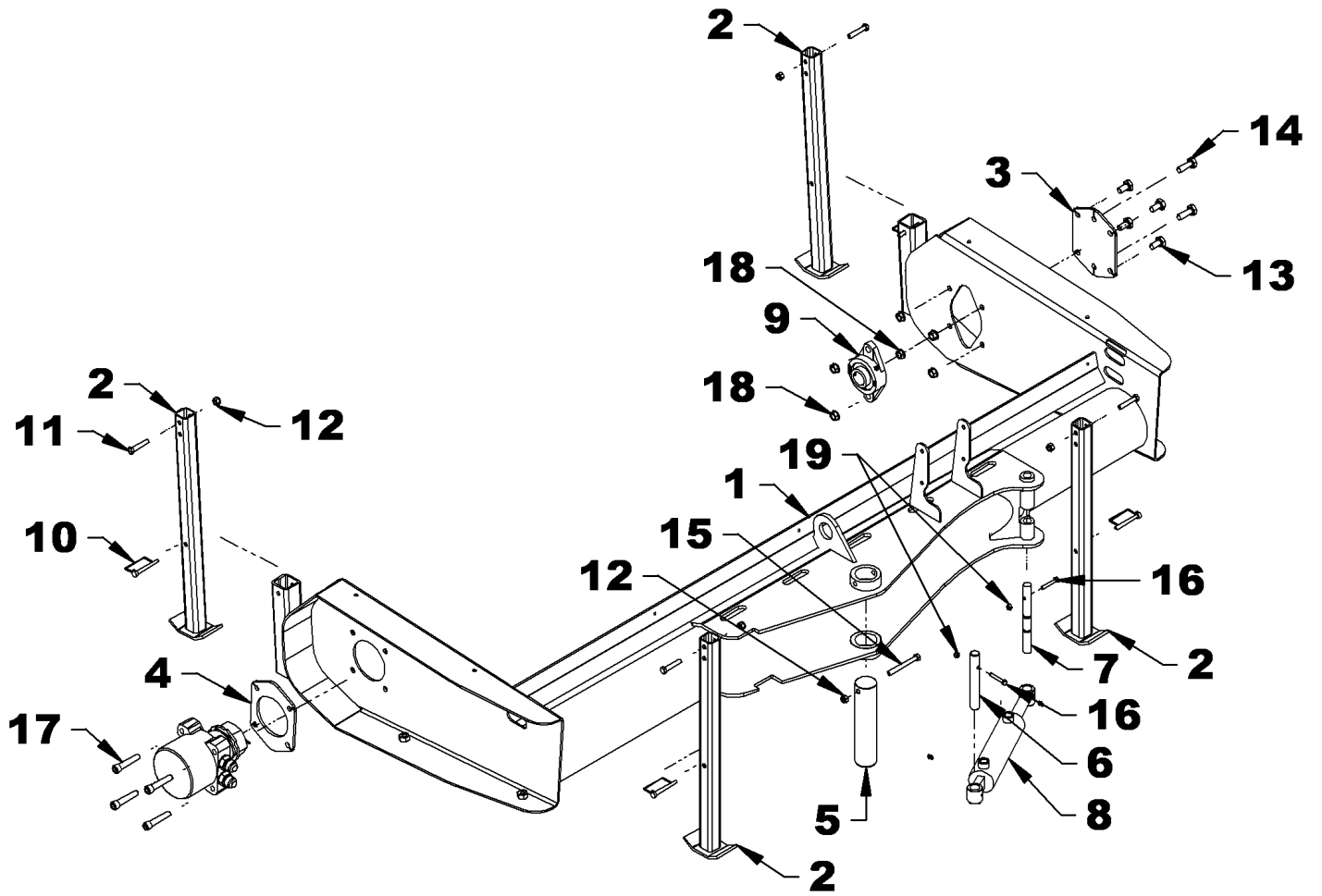
REF.	DESCRIPTION	QTY	PART #
1	Middle hitch	1	668158
2	Universal support	1	668159
3	Spring support	1	668160
4	Tension bolt 3/4" x 18.5" lg PTD	2	668164
5	Bushing PTD	2	668170
6	Pressure indicator support	1	668247
7	Pressure indicator	1	668248
8	Lever arm	1	668249
9	Bushing PTD	2	668250
10	Spacer ring	1	668213
11	Compression spring ø4" x 12" lg	3	2200017
12	Rotation bushing 2" x 2 1/2" lg	2	4300052
13	Grease fitting 1/4"NF	3	654106
14	Hex. bolt ø1 1/4"NC x 5 1/2" Gr.5 PTD	2	O/L
15	Flat washer ø1 1/4" PTD	4	O/L
16	Lockwasher ø1 1/4" PTD	2	O/L
17	Nylon insert jam nut ø1 1/4"NC PTD	2	1000029
18	Stover nut ø3/4"NC PTD	2	1100008
19	Flat washer ø3/4" PTD	2	O/L
20	Carriage bolt ø3/8" x 3" PTD	2	0300012
21	Flat washer ø5/8" PTD	1	O/L
22	Flat washer ø3/8" PTD	2	O/L
23	Lockwasher ø3/8" PTD	2	O/L
24	Nylon insert nut ø3/8"NC PTD	2	O/L
25	Carriage bolt ø1/2" x 1 1/4" PTD	2	0300023
26	Serrated flange nut 1/2"NC PTD	2	O/L

---

# PARTS

---

## ROTARY BROOM - HOUSING



# PARTS

## ROTARY BROOM - HOUSING

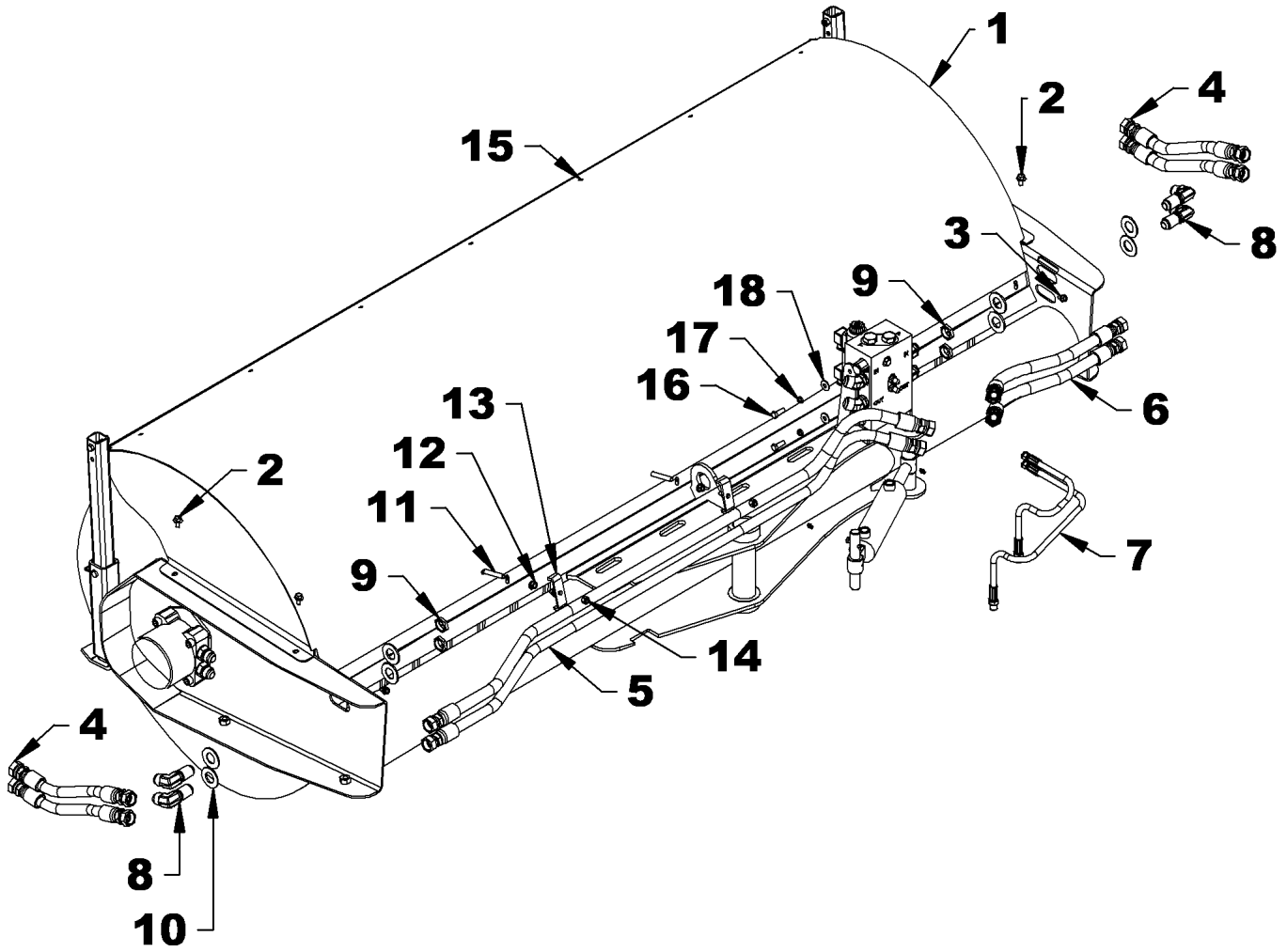
REF.	DESCRIPTION	QTY	PART #
1	84" broom housing	1	668149
	72" broom housing	1	668152
	60" broom housing	1	668155
2	Parking stand	4	668161
3	Support plate	1	668166
4	Spacer 1/4"	1	668168
	for HB8432XX	2	
	Spacer 1/8"	1	668169
5	Pivot pin	1	668174
6	Pin $\varnothing 7/8"$ x 6"	1	668172
7	Pin $\varnothing 3/4"$ x 7 $3/8"$	1	668173
8	Cylinder $\varnothing 2"$ x 6 $1/2"$	1	664979
9	Bearing $\varnothing 1 3/8"$ with setscrew	1	4300019
10	Square wire lock pin $\varnothing 3/8"$ x 2 $1/2"$	4	1900008
11	Bolt hex. $\varnothing 3/8"$ x 2" Gr.5 PTD	4	O/L
12	Nylon insert nut $\varnothing 3/8"$ PTD	4	O/L
13	Hex. bolt $\varnothing 1/2"$ x 1" Gr.5 PTD	4	O/L
14	Hex. bolt $\varnothing 1/2"$ x 1 $1/2"$ Gr.5 PTD	2	O/L
15	Hex. bolt $\varnothing 3/8"$ x 3 $1/2"$ Gr.5 PTD	1	O/L
16	Hex. bolt $\varnothing 1/4"$ x 1 $3/4"$ Gr.5 PTD	2	O/L
17	Allen socket head cap screw $\varnothing 1/2"$ NC x 2 $1/2"$ Gr.8	4	0800021
	for HB8432XX	8	
18	Serrated flange nut $\varnothing 1/2"$ NC PTD	10	O/L
	for HB8432XX	8	
19	Nylon insert nut $\varnothing 1/4"$ PTD	2	O/L

---

# PARTS

---

## ROTARY BROOM – HYDRAULIC HOSES



# PARTS

## ROTARY BROOM – HYDRAULIC HOSES

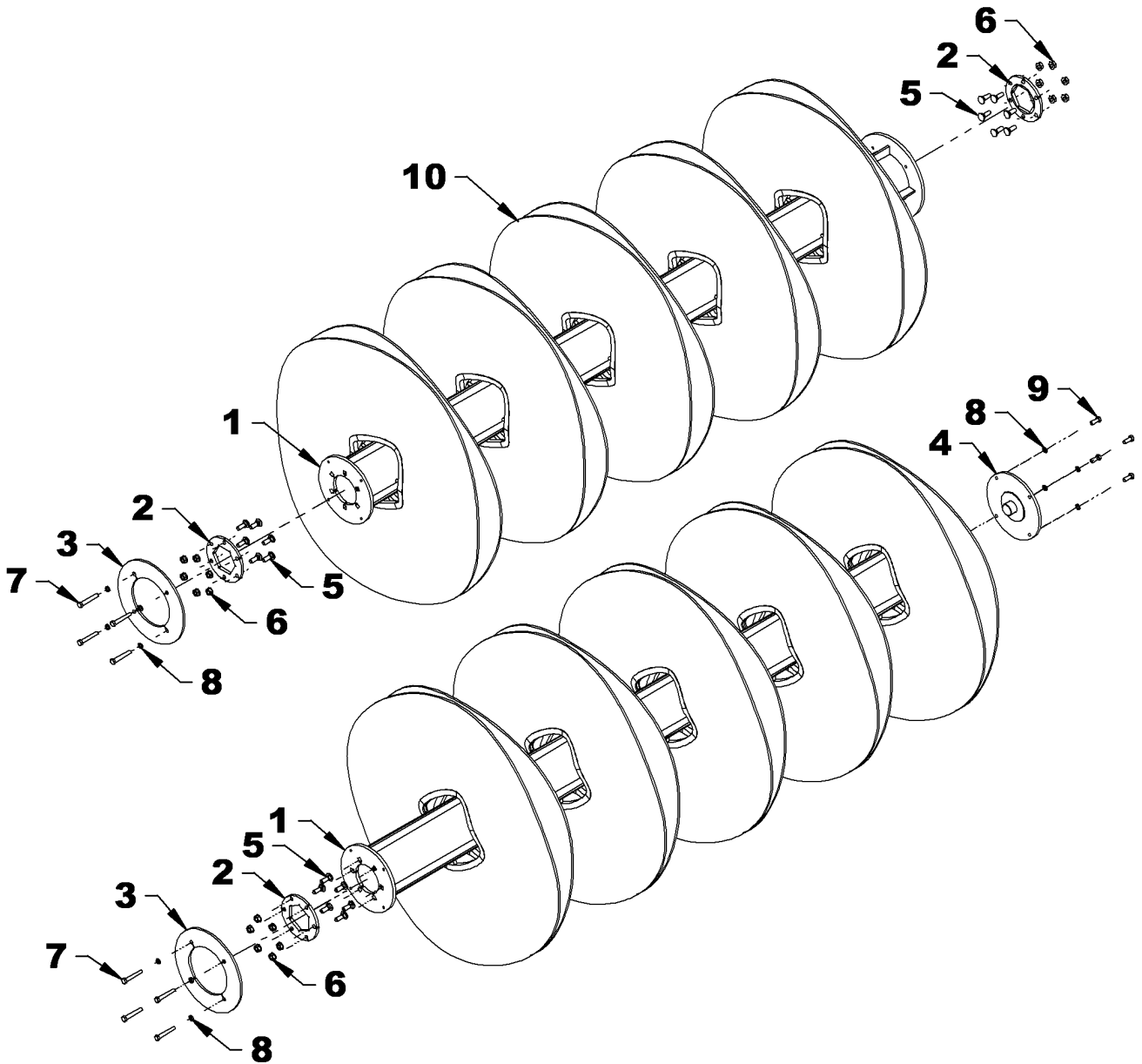
REF.	DESCRIPTION	QTY	PART #
1	84" brush cover	1	668151
	72" brush cover	1	668154
	60" brush cover	1	668157
2	Serrated flange bolt $\varnothing 5/16"$ x $3/4"$ PTD	4	0200083
3	Serrated flange bolt $\varnothing 5/16"$ x $1/2"$ PTD	5	0200065
4	Hose $\varnothing 3/4"$ x $15 1/2"$ - 1 $1/16"$ JIC fem. piv. X 1 $1/16"$ JIC fem. piv. for HB8432XX	2 4	3700130
5	Hose $\varnothing 3/4"$ x $61 1/2"$ - 1 $1/16"$ JIC fem. piv. X 1 $1/16"$ JIC fem. piv. (for 84" broom)	2	3700129
	Hose $\varnothing 3/4"$ x $49 1/2"$ - 1 $1/16"$ JIC fem. piv. X 1 $1/16"$ JIC fem. piv. (for 72" broom)	2	3700131
	Hose $\varnothing 3/4"$ x $37 1/2"$ - 1 $1/16"$ JIC fem. piv. X 1 $1/16"$ JIC fem. piv. (for 60" broom)	2	3700132
6	Hose $\varnothing 3/4"$ x $21"$ - 1 $1/16"$ JIC fem. piv. X 1 $1/16"$ JIC fem. piv.	2	3700133
7	Hose $\varnothing 1/4"$ x $24"$ - $7/16"$ JIC fem. piv. X $3/8"$ NPT male	2	3700136
8	Adaptor $90^\circ$ 1 $1/16"$ JIC male x 1 $1/16"$ JIC male for HB8432XX	2 4	2600164
9	Bulkhead nut 1 $1/16"$ JIC for HB8432XX	2 4	2600165
10	Flat washer 1" PTD for HB8432XX	4 8	O/L
11	Hex. bolt $\varnothing 3/8"$ NC x $2 1/2"$ (full thread) Gr.5 PTD	2	O/L
12	Serrated flange nut $\varnothing 3/8"$ NC PTD	2	O/L
13	Hose clamp	2	668171
14	Nylon insert nut $\varnothing 3/8"$ NC PTD	2	O/L
15	Plug $\varnothing 3/8"$ for material $1/16"$ to $1/8"$ thick for HB8432XX	6 7	3400009
16	Hex. bolt $\varnothing 3/8"$ NC x 1" Gr.5 PTD	4	O/L
17	Lockwasher $\varnothing 3/8"$ PTD	4	O/L
18	Flat washer $\varnothing 3/8"$ PTD	4	O/L

---

# PARTS

---

## BRUSH ASSEMBLY



# PARTS

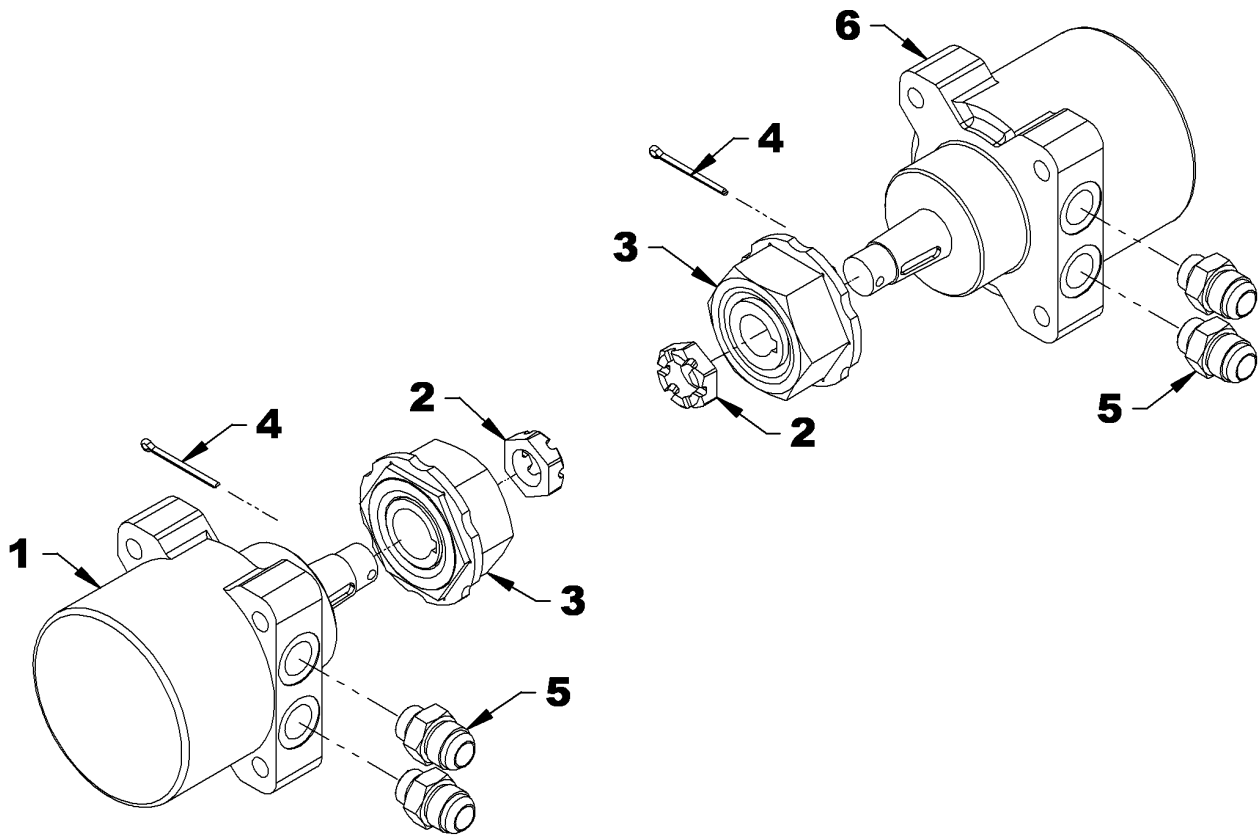
## BRUSH ASSEMBLY

REF.	DESCRIPTION	QTY	PART #
1	Brush support for 84" broom	1	668150
	Brush support for 72" broom	1	668153
	Brush support for 60" broom	1	668156
2	Drive plate	1	668167
	for HB8432XX	2	
3	Retaining plate	1	668165
4	Plug for brush support	1	668163
5	Carriage bolt $\varnothing$ 7/16"NC x 1 1/4" PTD	6	0300019
	for HB8432XX	12	
6	Serrated flange nut 7/16"NC PTD	6	O/L
	for HB8432XX	12	
7	Hex. bolt $\varnothing$ 3/8"NC x 2 1/2" (full thread) Gr.5 PTD	4	O/L
8	Lockwasher $\varnothing$ 3/8" PTD	8	O/L
	for HB8432XX	4	
9	Hex. bolt $\varnothing$ 3/8"NC x 1" Gr.5 PTD	4	O/L
10	Wafer brush (HB8432, HB8432XX)	45	3800063
	Wafer brush (HB7232, HB7232X)	38	3800063
	Wafer brush (HB6032, HB6032X)	32	3800063
<b>OPTIONS</b>			
<b>HB8432 &amp; HB8432XX</b>			
	Brush set $\varnothing$ 32" - 50% poly./50% steel		BR0008
	Brush set $\varnothing$ 32" - 100% polypropylene		BR0009
<b>HB7232 &amp; HB7232X</b>			
	Brush set $\varnothing$ 32" - 50% poly./50% steel		BR0010
	Brush set $\varnothing$ 32" - 100% polypropylene		BR0011
<b>HB6032 &amp; HB6032X</b>			
	Brush set $\varnothing$ 32" - 50% poly./50% steel		BR0012
	Brush set $\varnothing$ 32" - 100% polypropylene		BR0013

# PARTS

## HYDRAULIC MOTORS

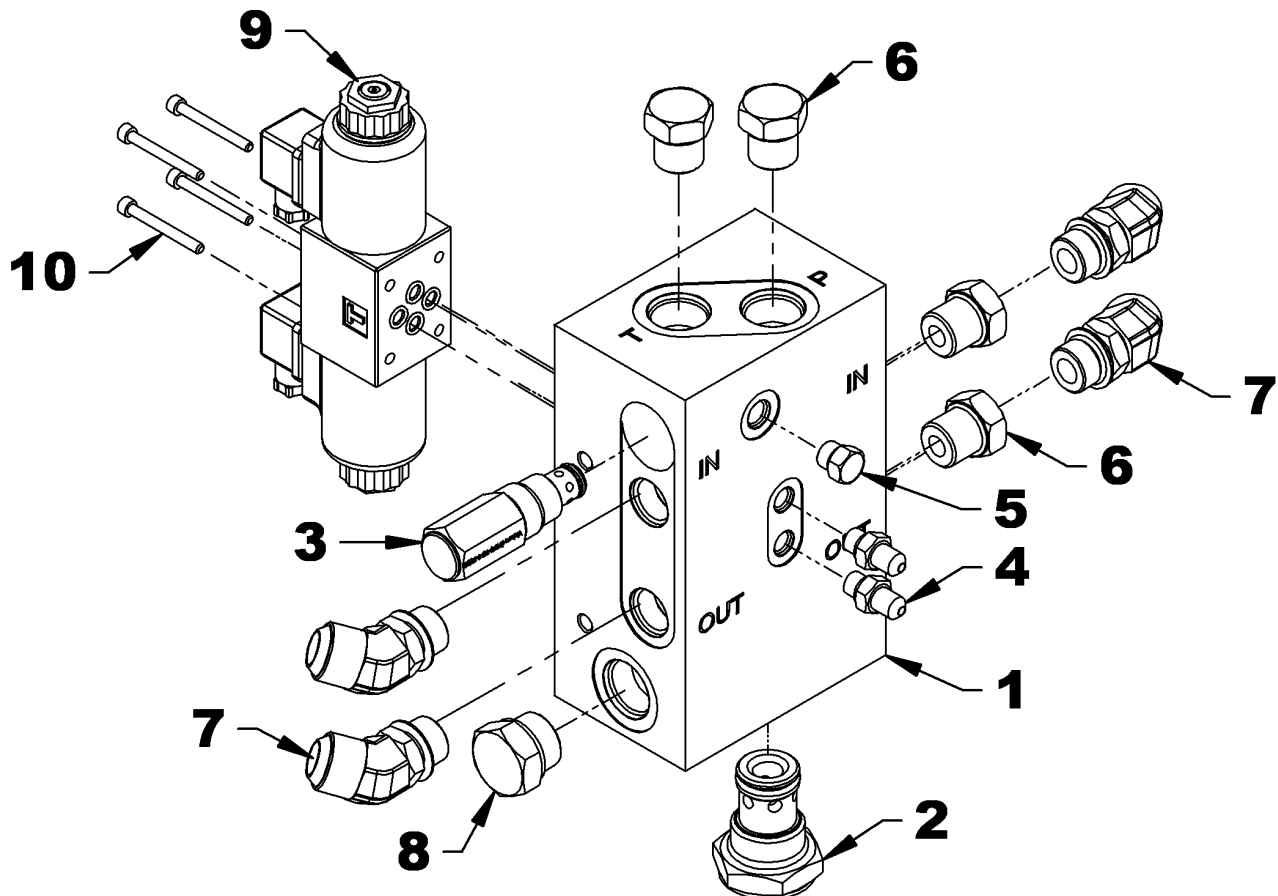
REF.	DESCRIPTION	QTY	PART #
1	Hydraulic motor 18.3 cu. in. 300cc (HB6032, HB7232 and HB8432XX)	1	3910001
	Hydraulic motor 23.2 cu. in. 375cc (HB6032X, HB7232X and HB8432)	1	3910003
2	Castle nut 1"-20NEF thin	1	1100026
	for HB8432XX	2	
3	Driving hub	1	668162
	for HB8432XX	2	
4	Cotter pin 5/32" x 2"	1	O/L
	for HB8432XX	2	
5	Fitting 7/8"ORB male x 1 1/16"JIC male	2	2600058
	for HB8432XX	4	
6	Hydraulic motor 18.3 cu. in. 300cc (HB8432XX)	1	3910002



# PARTS

## HYDRAULIC BLOCK

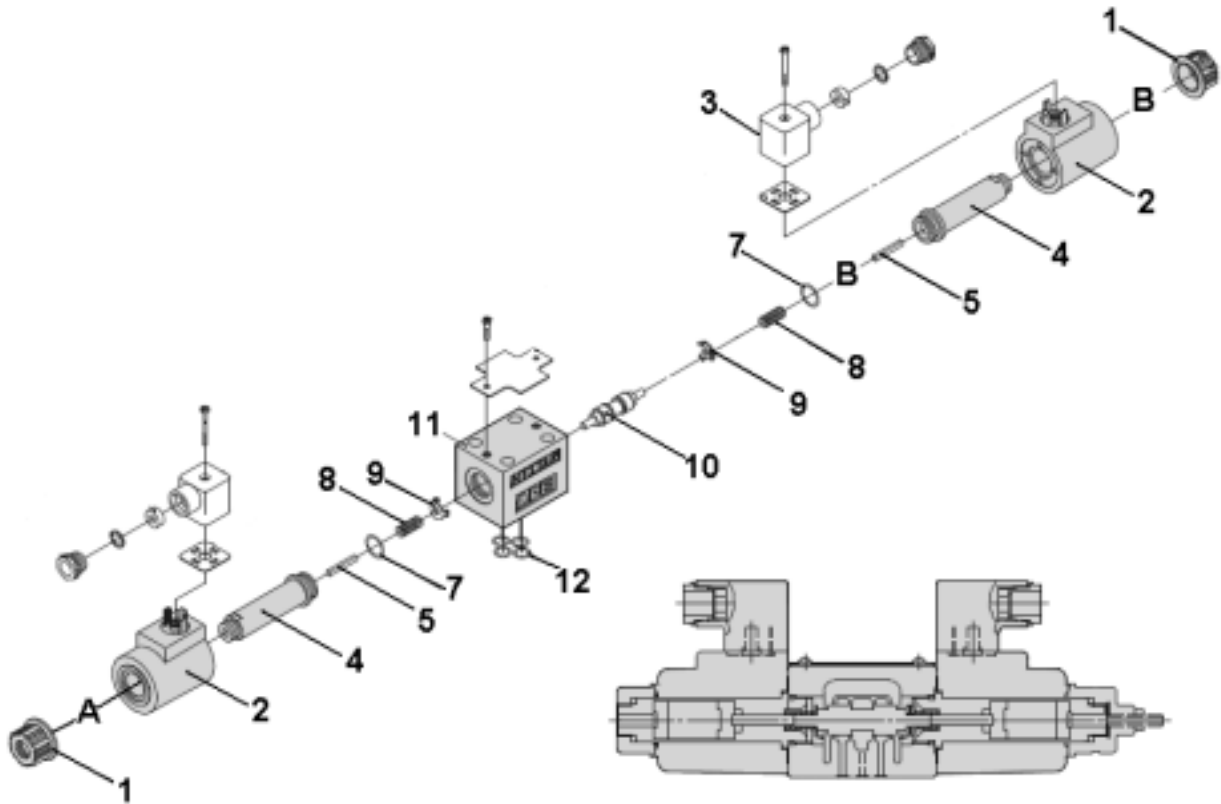
REF.	DESCRIPTION	QTY	PART #
1	Hydraulic block	1	2600162
2	By-pass valve	1	3920001
3	Relief valve	1	3920002
4	Adaptor 7/16"JIC male x 7/16"ORB male	2	2600123
5	Hydraulic plug hex. 1/2"ORB	1	2600167
6	Hydraulic plug hex. 7/8"ORB	4	2600086
	for HB8432XX	2	
7	Elbow 45° 1 1/16"JIC male x 7/8"ORB male	2	2600166
	for HB8432XX	4	
8	Hydraulic plug hex. 1 1/16"ORB	1	2600049
9	Electro-hydraulic valve center closed - 3 positions	1	3900027
10	Allen socket head cap screw 10-24 x 1 3/4"	4	0800018



# PARTS

## ELECTRO-HYDRAULIC VALVE

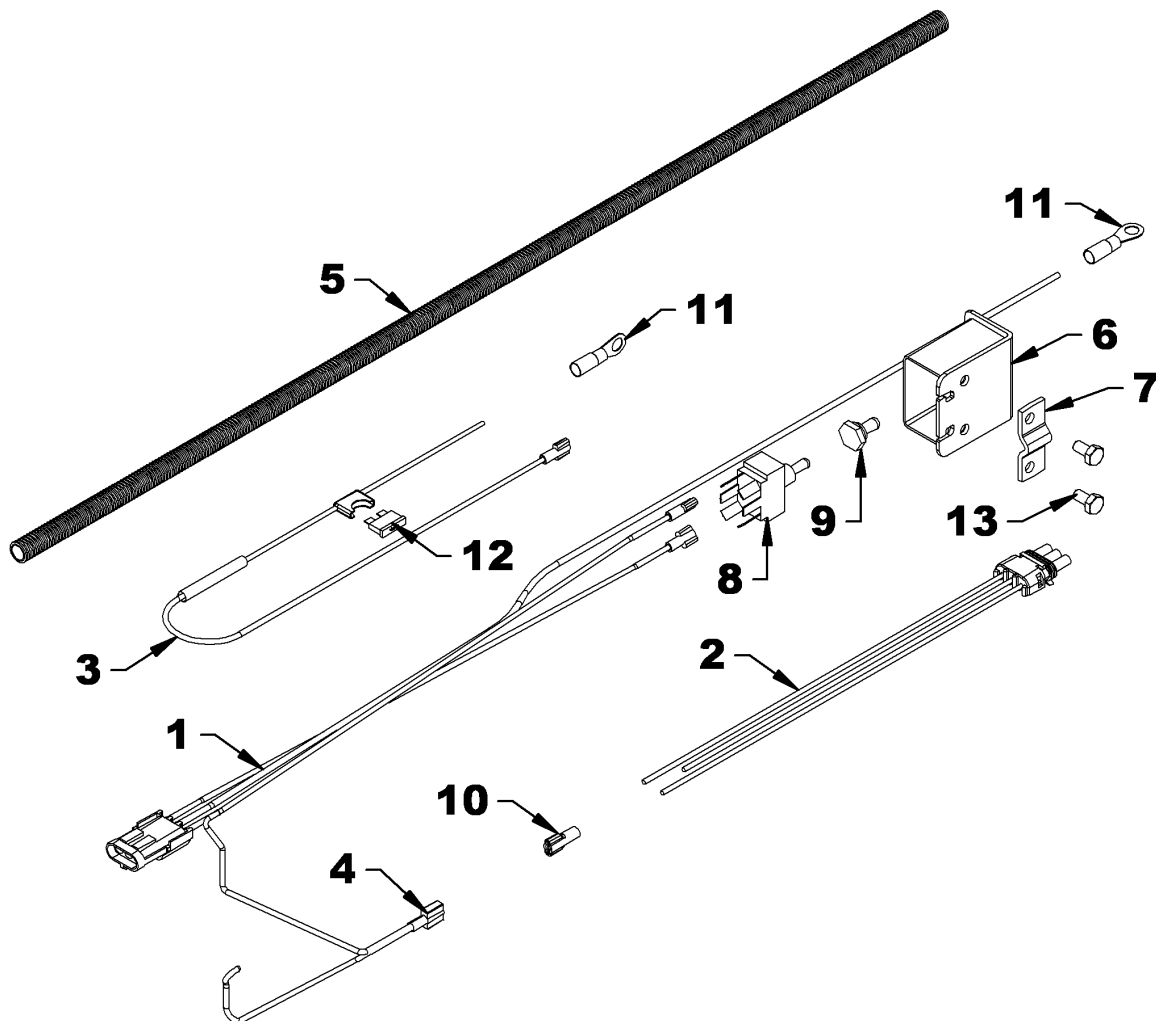
REF.	DESCRIPTION	QTY	PART #
1	Lock nut	2	3920004
2	Terminal	2	3920005
3	DIN connector	2	4000062
4-5	Tube & rod	2	3920006
8	Spring	2	3920007
9	Retaining clip	2	3920008
7-12	Seal kit	1	3920009
10	Piston	1	3920010
11	Body	1	3920011



# PARTS

## ELECTRICAL WIRING

REF.	DESCRIPTION	QTY	PART #
1	Main wire	1	668238
2	Secondary wire	1	668239
3	Battery wire	1	668240
4	Ground wire	1	668241
5	Loom $\varnothing 3/8"$ x 480"	1	668242
6	Switchbox	1	667557
7	Switchbox clamp	1	667558
8	Switch - 6 blades	1	4000027
9	Rubber cap for switch	1	658666
10	Female terminal - flat 6.3mm nylon insulated 10-12	1	663971
11	Terminal 10-12GA 5/16" hole round with thermoset splice	2	4000054
12	Fuse 10amp ATO	1	4000040
13	Hex bolt $\varnothing 1/4"$ NC x $1/2"$ Gr.5 PTD	2	O/L

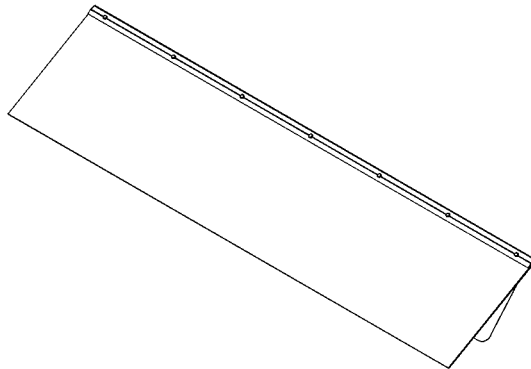


---

## AVAILABLE OPTIONS

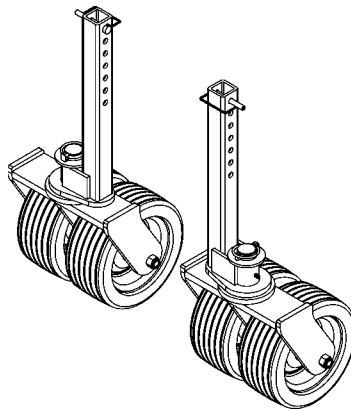
---

### DUST DEFLECTOR



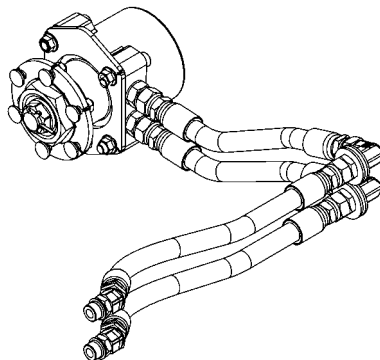
**BER0001, BER0002, BER0003**

### 6" LAWN DETHATCHING WHEEL KIT



**BER0004**

### SECOND HYDRAULIC MOTOR KIT



**BER0005**

---

# WARRANTY

---



## **RAD TECHNOLOGIES INC** *Theftord Mines Division*

RAD TECHNOLOGIES INC. warrants to the original buyer that the equipment is free from defects in material and workmanship. RAD TECHNOLOGIES INC.'s obligation, under this warranty, will be limited to the repair or replacement of any non-wear part or component, which RAD TECHNOLOGIES INC. finds to be defective within **one year** from the date of original purchase (unless otherwise-specified). The applicable warranty period for commercial or rental use shall be ninety (90) days from the date of purchase

In no event shall RAD TECHNOLOGIES INC. be liable for consequential, special, direct or indirect damages incurred by the buyer/user.

All components not manufactured by RAD TECHNOLOGIES INC. (such as motors, actuators, hydraulic components, tires, ...etc.) are covered by the original manufacturer's warranty in conjunction with RAD TECHNOLOGIES INC.

RAD's obligation under this warranty shall be limited to repairing or replacing, free of charge to the original purchaser, any part that, in RAD's judgment, shall show evidence of such defect, provided the **distributor** returns the part prepaid within thirty (30) days from date of failure.

This warranty shall not be interpreted to render RAD TECHNOLOGIES INC. liable for injuries or damages of any kind or nature to person or property. This warranty does not extend to losses because of delays, or to any expenses or losses incurred for labor, substitute machinery, rental or for any other reason.

Except as set forth above, RAD TECHNOLOGIES INC. shall have no obligation or liability of any kind on account of any of its equipment and shall not be liable for special or consequential damages. RAD TECHNOLOGIES INC. makes no other warranty, expressed or implied, and specifically, RAD TECHNOLOGIES INC. disclaims any implied warranty or merchantability or fitness for a particular purpose. **Some states or provinces do not permit limitations or exclusions of implied warranties or incidental or consequential damages, so the limitations or exclusions in this warranty may not apply.**

This warranty is subject to any existing conditions of supply, which may directly affect our ability to obtain materials or manufacture replacement parts. RAD TECHNOLOGIES INC. reserves the right to make improvements in design or changes in specifications at any time, without incurring any obligation to owners of units previously sold.

No one is authorized to alter, modify or enlarge this warranty nor the exclusions, limitations and reservations.

**2835 Chemin de l'Aéroport, Theftord Mines (Québec) G6G 5R7**

Tél.: (418) 338-4499 Fax: (418) 388-6090  
Internet : [www.radinter.com](http://www.radinter.com) Courriel : [radtech@radinter.com](mailto:radtech@radinter.com)

# TORQUE SPECIFICATION TABLE

## **GENERAL SPECIFICATION TABLE**

Use the following torques when special torques are not given. Note: These values apply to fasteners as received from supplier, when dry. These values do not apply if lubricants are used.

BOLT SIZES (SAE)	TORQUE	
INCHES	Pounds-Foot	Newton-Meters
1/4	5	7
5/16	10	14
3/8	20	27
7/16	25	41
1/2	88	119
5/8	165	224
3/4	297	403
9/16	121	164
7/8	440	597
1	638	865
1 1/8	840	1139
1 1/4	1180	1600
1 3/8	1570	2129
1 1/2	2070	2807

BOLT SIZES (METRIC)	TORQUE	
MILLIMETERS	Pounds-Foot	Newtons-Meter
M6	10	13
M8	22	30
M10	40	54
M12	59	80
M14	93	126
M16	130	176
M18	168	228
M20	205	278

# TORQUE SPECIFICATION TABLE

## **TORQUE SPECIFICATION TABLE FOR HYDRAULIC FITTINGS**

Use the following torques when a specific torque is not given. Note: These values apply to fittings when dry. These values do not apply if lubricants are used..

SIZE OF FITTINGS	TORQUE	
	foot-pounds	Newton-meters
<b>SIZE ( JIC ) - INCHES</b>		
<b>03 - 3/8" - 24</b>	<b>8-9</b>	<b>12-13</b>
<b>04 - 7/16" - 20</b>	<b>13-15</b>	<b>18-20</b>
<b>05 - 1/2" - 20</b>	<b>14-15</b>	<b>19-21</b>
<b>06 - 9/16" - 18</b>	<b>23-24</b>	<b>32-33</b>
<b>08 - 3/4" - 16</b>	<b>40-43</b>	<b>55-57</b>
<b>10 - 7/8" - 14</b>	<b>43-48</b>	<b>59-64</b>
<b>12 - 1 1/16" - 12</b>	<b>68-75</b>	<b>93-101</b>
<b>14 - 1 3/16" - 12</b>	<b>83-90</b>	<b>113-122</b>
<b>16 - 1 5/16" - 12</b>	<b>112-123</b>	<b>152-166</b>
<b>20 - 1 5/8" - 12</b>	<b>146-161</b>	<b>198-218</b>
<b>24 - 1 7/8" - 12</b>	<b>154-170</b>	<b>209-230</b>
<b>32 - 2 1/2" - 12</b>	<b>218-240</b>	<b>296-325</b>

SIZE ( ORB ) - INCHES	TORQUE	
	foot-pounds	Newton-meters
<b>03 - 3/8" - 24</b>	<b>8-10</b>	<b>11-13</b>
<b>04 - 7/16" - 20</b>	<b>14-16</b>	<b>20-22</b>
<b>05 - 1/2" - 20</b>	<b>18-20</b>	<b>24-27</b>
<b>06 - 9/16" - 18</b>	<b>24-26</b>	<b>33-35</b>
<b>08 - 3/4" - 16</b>	<b>50-60</b>	<b>68-78</b>
<b>10 - 7/8" - 14</b>	<b>72-80</b>	<b>98-110</b>
<b>12 - 1 1/16" - 12</b>	<b>125-135</b>	<b>170-183</b>
<b>14 - 1 3/16" - 12</b>	<b>160-180</b>	<b>215-245</b>
<b>16 - 1 5/16" - 12</b>	<b>200-220</b>	<b>270-300</b>
<b>20 - 1 5/8" - 12</b>	<b>210-280</b>	<b>285-380</b>
<b>24 - 1 7/8" - 12</b>	<b>270-360</b>	<b>370-490</b>

---

# TORQUE SPECIFICATION TABLE

---

SIZE ( NPT ) - INCHES	Torque FFT
<b>1/8" - 27</b>	<b>2.0 - 3.0</b>
<b>1/4" - 18</b>	<b>2.0 - 3.0</b>
<b>3/8" - 18</b>	<b>2.0 - 3.0</b>
<b>1/2" - 14</b>	<b>2.0 - 3.0</b>
<b>3/4" - 16</b>	<b>2.0 - 3.0</b>
<b>1" - 11 1/2"</b>	<b>1.5 - 2.5</b>
<b>1 1/4" - 11 1/2"</b>	<b>1.5 - 2.5</b>
<b>1 1/2" - 11 1/2"</b>	<b>1.5 - 2.5</b>

## ASSEMBLY

The method used to assemble fittings with NPT threads is in two stages. First tighten firmly by hand then tighten one again according to the number of turns listed on the above table. The following method is recommended to minimize the risks of leaks and/or damages to the parts.

5. Inspect threads and tapping to make sure they are clean.
6. Apply a sealant/lubricant product to the NPT threads (teflon covered threads are preferable to other lubricating products). If PTFE tape (teflon) is used, make 1,5 or 2 turns clockwise.

**Attention: More than 2 turns can cause distortion or cracks in the orifice.**

7. Tighten the fitting by hand.

8. Screw the fitting the number of turns listed on the above table making sure that in the case of a shape fitting the end is aligned to the desired position. **Never unscrew a fitting to obtain the proper alignment.**
9. If the leak persists after having followed the preceding instructions, check that the threads are not damaged and the number of seated threads.

If the threads are very damaged, replace the fitting. If the tapping is damaged, retap if possible or replace the part.

Usually, the number of threads seated is between 3, 5 and 6. If the range is different it would indicate that the fitting was tightened too much or not enough or that the tightening was not within thread tolerances. If the fitting is not tight enough, tighten but never more than one turn. If it's too tight, control the threading and tapping and replace the section that has threads that are not within tolerances.



Manufactured by:



***RAD TECHNOLOGIES INC.***

***Thetford Mines Division***

2835, Chemin de l'Aéroport

Thetford Mines, Québec, Canada, G6G 5R7

**Tel.: (418) 338-4499 - Fax.: (418) 338-6090**

**e-mail : [radtech@radinter.com](mailto:radtech@radinter.com)**

**Internet: [www.radinter.com](http://www.radinter.com)**

Printed in Canada